

RIGHT ANGLE PLUG CRIMP TYPE

R141.182.000

CABLE 5/50 S

Series : BNC

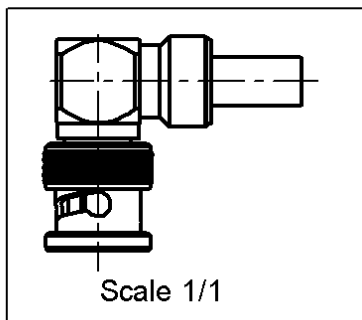
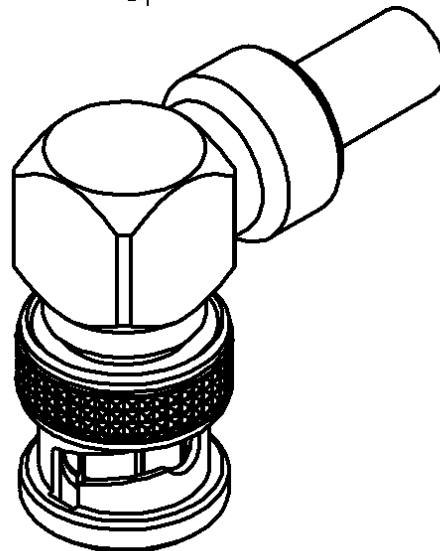
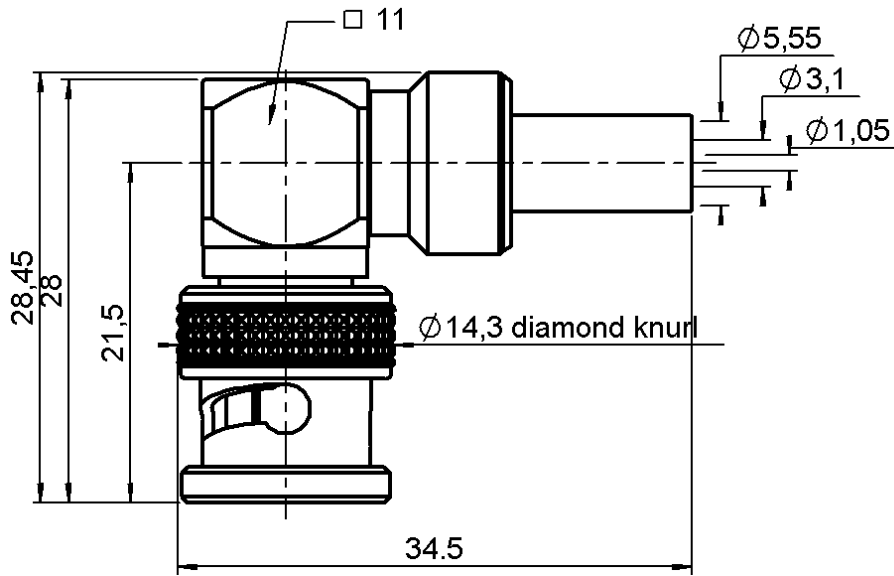

All dimensions are in mm.



COMPONENTS	MATERIALS	PLATING (µm)
BODY	BRASS	NICKEL 2
CENTER CONTACT	BERYLLIUM COPPER, BRASS	GOLD 0.5 OVER NICKEL 2
OUTER CONTACT	-	-
INSULATOR	PTFE	-
GASKET	SILICONE RUBBER	-
OTHERS PARTS	BRASS	NICKEL 2
-	-	-
-	-	-

Issue : 0718 U

In the effort to improve our products, we reserve the right to make changes judged to be necessary.



RIGHT ANGLE PLUG CRIMP TYPE

R141.182.000

CABLE 5/50 S

Series : **BNC**

PACKAGING

Standard	Unit	Other
100	'W' option	Contact us

SPECIFICATION

ELECTRICAL CHARACTERISTICS

Impedance	50	Ω
Frequency	0-4	GHz
VSWR	1.35 + 0,0000	x F(GHz) Maxi
Insertion loss	0.175	\sqrt{F} (GHz) dB Maxi
RF leakage	- (57)	- F(GHz)) dB Maxi
Voltage rating	500	Veff Maxi
Dielectric withstanding voltage	1500	Veff mini
Insulation resistance	5000	M Ω mini

CABLE ASSEMBLY

Stripping	a	b	c	d	e	f
mm	4,00	8,50	15,0	0,00	11,0	0,00

Assembly instruction : **CRIMP 02**

Recommended cable(s)

RG 141
KX 15
RG 58

Characteristics indicated on this data sheet are those that can be achieved with the highest performance cable. Intrinsic limitations of the cable may diminish the performance of the assembly

Cable retention

- pull off **90** N mini
- torque **NA** N.cm

MECHANICAL CHARACTERISTICS

Center contact retention		
Axial force – Mating end	27	N mini
Axial force – Opposite end	27	N mini
Torque	NA	N.cm mini

TOOLING

Part Number	Description	Hexagon
.	.	.
R282.223.000	CRIMPING TOOL	1.73-5.41
R282.235.011	CRIMPING DIES M22520/5-11	1.73-5.41
R282.293.000	CRIMPING TOOL M22520/5-01	-

Recommended torque		
Mating	NA	N.cm
Panel nut	NA	N.cm
Clamp nut	NA	N.cm
A/F clamp nut	0,0000	mm

Mating life	500	Cycles mini
Weight	24,0000	g

OTHER CHARACTERISTICS

-

ENVIRONMENTAL

Operating temperature	-65/+165	$^{\circ}$ C
Hermetic seal	NA	Atm.cm3/s
Panel leakage	NA	

Issue : **0718 U**

In the effort to improve our products, we reserve the right to make changes judged to be necessary.

