

**A multi-function sensor of excellent operability**



**NPN / PNP dual output**

**Simple teaching using a single button**

**Large easy-to-read display**

**Mutual interference prevention function**

**Two displacement display options available**



# User-friendly operability with essential functions

## 1 Simple teaching using a single button

Simple to sequentially select from four teaching modes using the [SET] button.

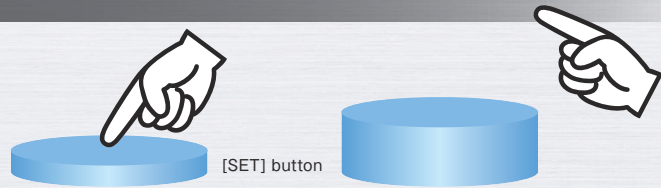

Four types of teaching mode are available

### 1 Two-point teaching mode

The threshold is set at the mid-point between the light intensity levels set in two-point teaching mode.



### 2 Position teaching mode

Set the threshold required at the detecting location.

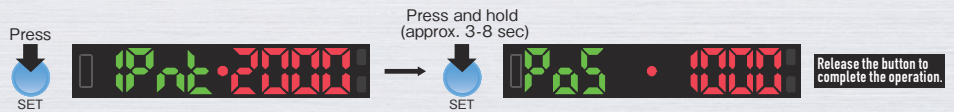

### 3 Maximum sensitivity teaching mode

The threshold level is automatically set to a value higher than the maximum light intensity being received while [SET] is pressed.



### 4 Full auto teaching mode

The threshold level is set at the mid-point between the maximum and minimum values being received while [SET] is pressed.



## 2 Easy to use with a large display and only three operation buttons

Two large clear 4-digit, 7-segment LED displays and three raised buttons with positive click feedback, making mode setting easy.



## 3 Mutual interference prevention function

Equipped with an optical transmission type mutual interference prevention function to suppress the interference between up to eight units. (Standard and Long mode)



### ■ Detecting distance

Appearance	Model	Detecting method	Detecting distance (mm)		
			Long (Long)	standard(Std)	High speed(H-SP)
	FR5BC	Reflective	500	330	160
	FT5BC	Through beam	1300	800	360



# Useful functions

## 4 Two displacement display options available

Light intensity received by two or more sensors can be easily read and compared by two displacement display options: Percentage for Through Beam type, and Zero Offset for Reflective type.

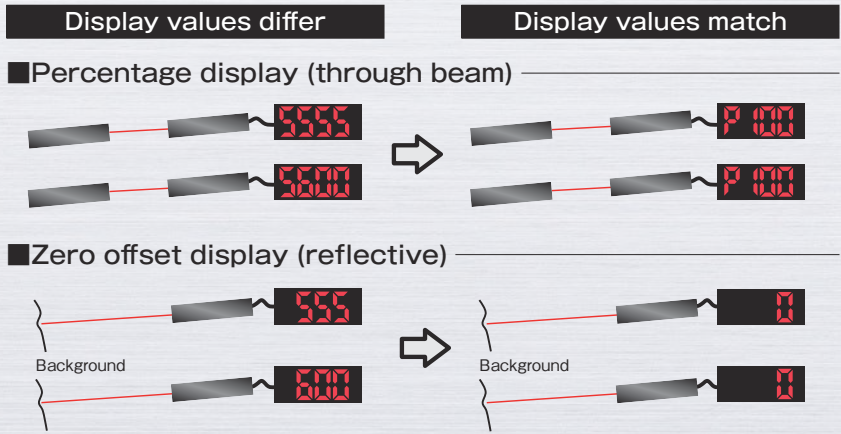

Detection allowance can be checked by comparing the percentage values of each sensor operation through the displacement display.

(The below examples show deterioration in detection allowance of Through Beam type.)

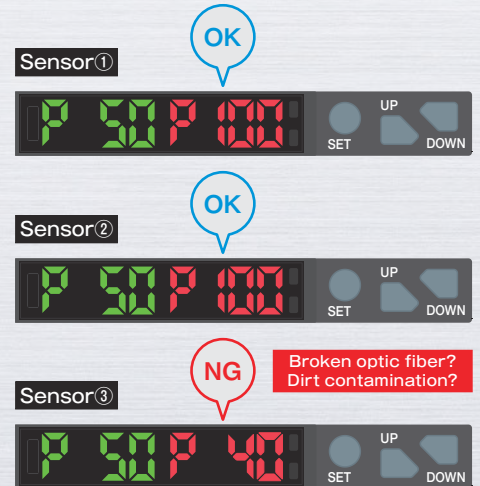

## 5 Light source intensity adjustment (Automatic/Manual)

Light intensity is adjusted to an optimum level for detection among 15 stages (13 stages at high-speed mode).

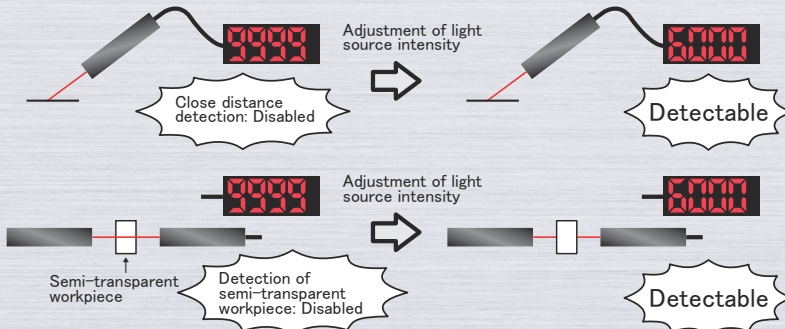

## 6 NPN/PNP dual output

As both connection types for the control output are available, configuring the output as PNP or NPN is not necessary.

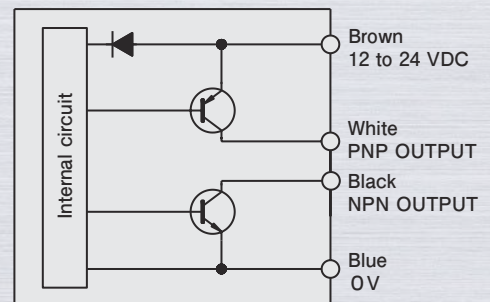

## 7 An energy-saving design and ECO mode realize low power consumption

24V normal mode: 770 mW or less / ECO mode: 600 mW or less

## 8 Manuals can be viewed on smartphones or tablets

The sensor comes with a QR code label and a quick reference guide is available on your smartphone or tablet (Japanese, English, Chinese, and Korean versions available). This is useful when checking the manual or changing the settings at installation site.



**NOTE**  
This function requires a device that can scan the QR code, connect to the Internet and display a PDF file. For details please refer to the instruction manual of the device.

## RATING/PERFORMANCE/SPECIFICATION

Model	F85RN
Power supply	12 to 24 V DC $\pm 10\%$ / Ripple 10% or less
Power consumption	Normal mode : 770 mW or less (32 mA or less at 24 V) ECO mode : 600 mW or less (25 mA or less at 24 V)
Control output	NPN open collector output / Load current 100 mA (30 V DC) or less / Residual voltage: 1 V or less PNP open collector output / Load current 100 mA (30 V DC) or less / Residual voltage: 2 V or less
Operation mode	Light ON/Dark ON
Timer	ON delay / OFF delay / ON/OFF delay / One shot/ No timer
	Delay timer: 1 to 9999 ms (set in milliseconds)
Response time	High speed mode: 65 $\mu$ s or less / Standard mode: 500 $\mu$ s or less / Long mode: 4 ms or less
Light source (wavelength)	Four-element (AlGaInp) red LED (660 nm)
Indicator	Operation indicator, Setting indicator, Light ON / Dark ON indicator: orange LED
Display	Received light level: 4 digits in red LED (high-speed mode (0 to 3800), standard / long mode (0 to 9999)) Threshold: 4 digits in green LED (high-speed mode (0 to 3500), standard / long mode (0 to 9700))
Switch	Teaching and set switch (SET) Switch for threshold adjustment (UP/DOWN)
Sensitivity setting	2-point teaching / Max. sensitivity teaching / Full auto teaching / Position teaching
Sensitivity adjustment	Provided (manual)
Light source intensity adjustment	Provided (automatic/manual)
Mutual Interference prevention	UP to 8 units (standard / long mode)
Protection circuit	Power supply reverse connection protection / Output short circuit protection
Material	Polycarbonate
Wiring	2 m attached cable (Outer dimension: dia. 4.2 mm) 0.2 mm <sup>2</sup> , 4 cores
Weight	Approx. 75 g
Accessory	Instruction manual / QR code label for simplified manual

## ENVIRONMENTAL SPECIFICATION

Ambient light	Illumination on light receiving surface: 3,500 lx or less (incandescent lamp)
Ambient temperature	1 to 5 adjacent units in operation: -25 to +55°C 6 or more adjacent units in operation: -25 to +50°C Storage: -40 to +70°C (non-freezing, non-condensing)
Ambient humidity	35 to 85% RH (non-condensing)
Protective structure	IP40
Vibration	10 to 55 Hz / 1.5 mm double amplitude / 2 hours each in X, Y, and Z directions
Shock	500 m/s <sup>2</sup> / 3 times each in X, Y and Z directions
Dielectric withstanding	1000 V AC for 1 minute
Insulation resistance	500 V DC mega, 20 M $\Omega$ or more

## DIMENSIONS (in mm)

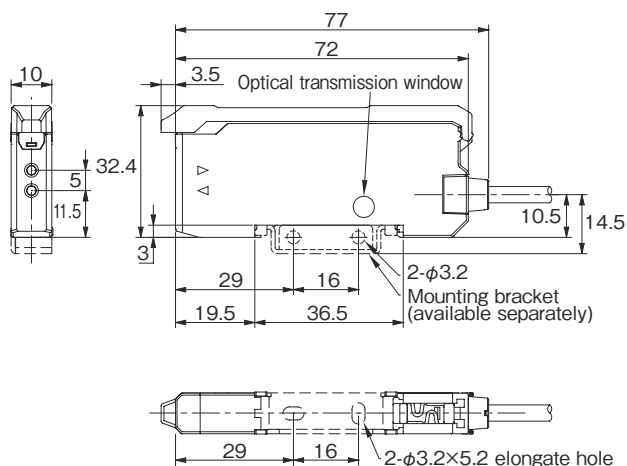

### FIBER AMPLIFIER

	Model
	F85RN

### MOUNTING BRACKET

	Model
	AC-BF3

### TERMINAL UNIT

	Model
	FA7EU



- This product is designed for industrial applications to detect a various kinds of objects. It has no function to prevent disasters, accidents, death or injuries.
- TAKEX will not held responsible for any damage or loss incurred due to accidents, faulty installation, abuse, misuse, improper maintenance or acts of God including lightning surge.
- This product cannot be used as safety equipment.
- This product is designed and manufactured for industrial use. It cannot be used where there is a requirement for a high degree of reliability or considerable care or attention to safety.
- Read this instruction manual carefully and use the product properly according to it.
- This instruction manual including the specifications and dimensions may be subject to change without notice.



Takenaka Sensor Group

**TAKENAKA ELECTRONIC INDUSTRIAL CO.,LTD.**

20-1 Shinomiya Narano-cho, Yamashina, Kyoto 607-8032 Japan

Tel: +81-75-581-7111 Fax: +81-75-581-7118

URL : <http://www.takex-elec.co.jp> email : [info-ex@takex-elec.co.jp](mailto:info-ex@takex-elec.co.jp)

Distributed by