

SN74AUP1G74 Low-Power Single Positive-Edge-Triggered D-Type Flip-Flop With Clear and Preset

1 Features

- Available in the Texas Instruments NanoStar™ Package
- Low Static-Power Consumption:
 $I_{CC} = 0.9 \mu\text{A}$ Maximum
- Low Dynamic-Power Consumption:
 $C_{pd} = 5.5 \text{ pF}$ Typical at 3.3 V
- Low Input Capacitance: $C_i = 1.5 \text{ pF}$ Typical
- Low Noise – Overshoot and Undershoot
< 10% of V_{CC}
- I_{off} Supports Partial-Power-Down Mode Operation
- Schmitt-Trigger Action Allows Slow Input Transition and Better Switching Noise Immunity at the Input
($V_{hys} = 250 \text{ mV}$ Typical at 3.3 V)
- Wide Operating V_{CC} Range of 0.8 V to 3.6 V
- Optimized for 3.3-V Operation
- 3.6-V I/O Tolerant to Support Mixed-Mode Signal Operation
- $t_{pd} = 5 \text{ ns}$ Maximum at 3.3 V
- Suitable for Point-to-Point Applications
- Latch-Up Performance Exceeds 100 mA Per JESD 78, Class II
- ESD Performance Tested Per JESD 22
 - 2000-V Human-Body Model (A114-B, Class II)
 - 1000-V Charged-Device Model (C101)

2 Applications

- Servers
- LED Displays
- Network Switches
- Telecom Infrastructure
- Motor Drivers
- I/O Expanders

3 Description

The AUP family is TI's premier solution to the industry's low-power needs in battery-powered portable applications. This family ensures a very low static- and dynamic-power consumption across the entire V_{CC} range of 0.8 V to 3.6 V, resulting in increased battery life. This product also maintains excellent signal integrity (see the very low undershoot and overshoot characteristics shown in [Figure 6](#)).

Device Information⁽¹⁾

PART NUMBER	PACKAGE	BODY SIZE (NOM)
SN74AUP1G74YFP	DSBGA (8)	1.56 mm × 0.76 mm
SN74AUP1G74YZP	DSBGA (8)	1.86 mm × 0.89 mm
SN74AUP1G74DCU	VSSOP (8)	2.30 mm × 2.00 mm
SN74AUP1G74DQE	X2SON (8)	1.40 mm × 1.00 mm
SN74AUP1G74RSE	UQFN (8)	1.50 mm × 1.50 mm

(1) For all available packages, see the orderable addendum at the end of the data sheet.

AUP – The Lowest-Power Family

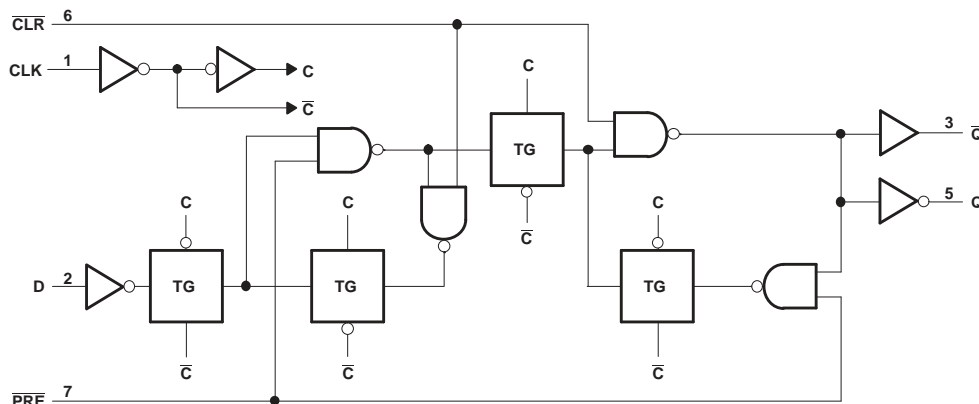

Table of Contents

1 Features 1 2 Applications 1 3 Description 1 4 Revision History 2 5 Pin Configuration and Functions 3 6 Specifications 4 6.1 Absolute Maximum Ratings 4 6.2 ESD Ratings 4 6.3 Recommended Operating Conditions 4 6.4 Thermal Information 5 6.5 Electrical Characteristics, $T_A = 25^\circ\text{C}$ 5 6.6 Electrical Characteristics, $T_A = -40^\circ\text{C}$ to $+85^\circ\text{C}$ 6 6.7 Timing Requirements 7 6.8 Switching Characteristics, $C_L = 5\text{ pF}$ 8 6.9 Switching Characteristics, $C_L = 10\text{ pF}$ 9 6.10 Switching Characteristics, $C_L = 15\text{ pF}$ 10 6.11 Switching Characteristics, $C_L = 30\text{ pF}$ 11 6.12 Operating Characteristics 12 6.13 Typical Characteristics 12 7 Parameter Measurement Information 13 7.1 Propagation Delays, Setup and Hold Times, and Pulse Width) 13	7.2 Enable and Disable Times 14 8 Detailed Description 15 8.1 Overview 15 8.2 Functional Block Diagram 15 8.3 Feature Description 15 8.4 Device Functional Modes 15 9 Application and Implementation 16 9.1 Application Information 16 9.2 Typical Power Button Circuit 16 10 Power Supply Recommendations 17 11 Layout 17 11.1 Layout Guidelines 17 11.2 Layout Example 17 12 Device and Documentation Support 18 12.1 Documentation Support 18 12.2 Community Resources 18 12.3 Trademarks 18 12.4 Electrostatic Discharge Caution 18 12.5 Glossary 18 13 Mechanical, Packaging, and Orderable Information 18
----------------------------------------------------------------------------------------------------------------------------------------------------------------------------------------------------------------------------------------------------------------------------------------------------------------------------------------------------------------------------------------------------------------------------------------------------------------------------------------------------------------------------------------------------------------------------------------------------------------------------------------------------------------------------------------------------------------------------------------------------------------------------------------------------------------------------------------------------------------------------------------------------------------------------------------------------------------------------------------------------------------------------------------------------------------------	--------------------------------------------------------------------------------------------------------------------------------------------------------------------------------------------------------------------------------------------------------------------------------------------------------------------------------------------------------------------------------------------------------------------------------------------------------------------------------------------------------------------------------------------------------------------------------------------------------------------------------------------------------------------------------------------------------------------------------------------------------------------------------------------------------------------------------------------

4 Revision History

NOTE: Page numbers for previous revisions may differ from page numbers in the current version.

Changes from Revision C (March 2010) to Revision D

Page

- | | |
|---------------------------------------------------------------------------------------------------------------------------------------------------------------------------------------------------------------------------------------------------------------------------------------------------------------------------------------------------------------------------------------------------------------------------------------------------------|---|
| <ul style="list-style-type: none"> • Added <i>Pin Configuration and Functions</i> section, <i>ESD Ratings</i> table, <i>Feature Description</i> section, <i>Device Functional Modes</i>, <i>Application and Implementation</i> section, <i>Power Supply Recommendations</i> section, <i>Layout</i> section, <i>Device and Documentation Support</i> section, and <i>Mechanical, Packaging, and Orderable Information</i> section 1 | 1 |
|---------------------------------------------------------------------------------------------------------------------------------------------------------------------------------------------------------------------------------------------------------------------------------------------------------------------------------------------------------------------------------------------------------------------------------------------------------|---|

5 Pin Configuration and Functions

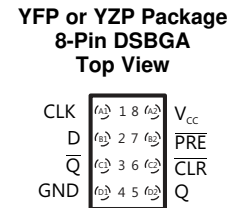
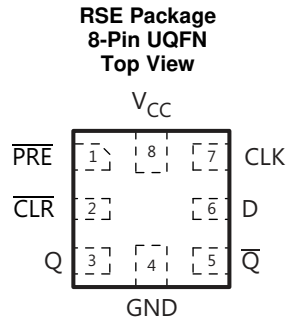
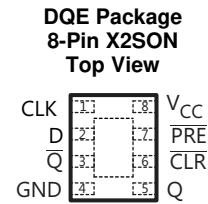
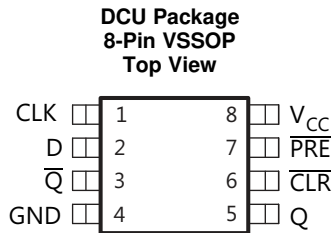

Pin Functions⁽¹⁾

NAME	PIN			I/O	DESCRIPTION
	VSSOP, X2SON	UQFN	DSBGA		
CLK	1	7	A1	I	Rising edge triggered clock signal input
$\overline{\text{CLR}}$	6	2	C2	I	Clear, Active low
D	2	6	B1	I	Data input
GND	4	4	D1	—	Ground
$\overline{\text{PRE}}$	7	1	B2	I	Preset, Active low
Q	5	3	D2	O	Output
$\overline{\text{Q}}$	3	5	C1	O	Inverted output
V _{CC}	8	8	A2	—	Power supply

(1) See [Mechanical, Packaging, and Orderable Information](#) for dimensions.

6 Specifications

6.1 Absolute Maximum Ratings

 over operating free-air temperature range (unless otherwise noted)⁽¹⁾

		MIN	MAX	UNIT
V _{CC}	Supply voltage	-0.5	4.6	V
V _I	Input voltage ⁽²⁾	-0.5	4.6	V
V _O	Voltage applied to any output in the high-impedance or power-off state ⁽²⁾	-0.5	4.6	V
V _O	Output voltage in the high or low state ⁽²⁾	-0.5	V _{CC} + 0.5	V
I _{IK}	Input clamp current	V _I < 0	-50	mA
I _{OK}	Output clamp current	V _O < 0	-50	mA
I _O	Continuous output current		±20	mA
	Continuous current through V _{CC} or GND		±50	mA
T _J	Junction temperature		150	°C
T _{stg}	Storage temperature	-65	150	

(1) Stresses beyond those listed under *Absolute Maximum Ratings* may cause permanent damage to the device. These are stress ratings only, which do not imply functional operation of the device at these or any other conditions beyond those indicated under *Recommended Operating Conditions*. Exposure to absolute-maximum-rated conditions for extended periods may affect device reliability.

(2) The input negative-voltage and output voltage ratings may be exceeded if the input and output current ratings are observed.

6.2 ESD Ratings

		VALUE	UNIT
V _(ESD)	Electrostatic discharge	Human-body model (HBM), per ANSI/ESDA/JEDEC JS-001 ⁽¹⁾	±2000
		Charged-device model (CDM), per JEDEC specification JESD22-C101 ⁽²⁾	±1000

(1) JEDEC document JEP155 states that 500-V HBM allows safe manufacturing with a standard ESD control process.

(2) JEDEC document JEP157 states that 250-V CDM allows safe manufacturing with a standard ESD control process.

6.3 Recommended Operating Conditions⁽¹⁾

		MIN	MAX	UNIT
V _{CC}	Supply voltage	0.8	3.6	V
V _{IH}	High-level input voltage	V _{CC} = 0.8 V	V _{CC}	V
		V _{CC} = 1.1 V to 1.95 V	0.7 × V _{CC}	
		V _{CC} = 2.3 V to 2.7 V	1.6	
		V _{CC} = 3 V to 3.6 V	2	
V _{IL}	Low-level input voltage	V _{CC} = 0.8 V	0	V
		V _{CC} = 1.1 V to 1.95 V	0.3 × V _{CC}	
		V _{CC} = 2.3 V to 2.7 V	0.7	
		V _{CC} = 3 V to 3.6 V	0.9	
V _I	Input voltage	0	3.6	V
V _O	Output voltage	0	V _{CC}	V
I _{OH}	High-level output current	V _{CC} = 0.8 V	-20	mA
		V _{CC} = 1.1 V	-1.1	
		V _{CC} = 1.4 V	-1.7	
		V _{CC} = 1.65	-1.9	
		V _{CC} = 2.3 V	-3.1	
		V _{CC} = 3 V	-4	

(1) All unused inputs of the device must be held at V_{CC} or GND to ensure proper device operation. See the TI application report, *Implications of Slow or Floating CMOS Inputs*, SCBA004.

Recommended Operating Conditions⁽¹⁾ (continued)

		MIN	MAX	UNIT	
I_{OL}	Low-level output current	$V_{CC} = 0.8\text{ V}$	20	μA	
		$V_{CC} = 1.1\text{ V}$	1.1	mA	
		$V_{CC} = 1.4\text{ V}$	1.7		
		$V_{CC} = 1.65\text{ V}$	1.9		
		$V_{CC} = 2.3\text{ V}$	3.1		
		$V_{CC} = 3\text{ V}$	4		
$\Delta t/\Delta v$	Input transition rise or fall rate	$V_{CC} = 0.8\text{ V to }3.6\text{ V}$		200	ns/V
T_A	Operating free-air temperature	-40	85	$^{\circ}\text{C}$	

6.4 Thermal Information

THERMAL METRIC ⁽¹⁾	SN74AUP1G74				UNIT	
	DCU (VSSOP)	DQE (X2SON)	RSE (UQFN)	YFP/YZP (DSBGA)		
	8 PINS	8 PINS	8 PINS	8 PINS		
$R_{\theta JA}$	Junction-to-ambient thermal resistance	227	261	253	102	$^{\circ}\text{C/W}$

(1) For more information about traditional and new thermal metrics, see the *Semiconductor and IC Package Thermal Metrics* application report, [SPRA953](#).

6.5 Electrical Characteristics, $T_A = 25^{\circ}\text{C}$

over recommended operating free-air temperature range (unless otherwise noted)

PARAMETER	TEST CONDITIONS	V_{CC}	MIN	TYP	MAX	UNIT
V_{OH}	$I_{OH} = -20\ \mu\text{A}$	0.8 V to 3.6 V	$V_{CC} - 0.1$			V
	$I_{OH} = -1.1\text{ mA}$	1.1 V	$0.7 \times V_{CC}$			
	$I_{OH} = -1.7\text{ mA}$	1.4 V	1.11			
	$I_{OH} = -1.9\text{ mA}$	1.65 V	1.32			
	$I_{OH} = -2.3\text{ mA}$	2.3 V	2.05			
	$I_{OH} = -3.1\text{ mA}$		1.9			
	$I_{OH} = -2.7\text{ mA}$	3 V	2.72			
	$I_{OH} = -4\text{ mA}$		2.6			
V_{OL}	$I_{OL} = 20\ \mu\text{A}$	0.8 V to 3.6 V			0.1	V
	$I_{OL} = 1.1\text{ mA}$	1.1 V			$0.3 \times V_{CC}$	
	$I_{OL} = 1.7\text{ mA}$	1.4 V			0.31	
	$I_{OL} = 1.9\text{ mA}$	1.65 V			0.31	
	$I_{OL} = 2.3\text{ mA}$	2.3 V			0.31	
	$I_{OL} = 3.1\text{ mA}$				0.44	
	$I_{OL} = 2.7\text{ mA}$	3 V			0.31	
	$I_{OL} = 4\text{ mA}$				0.44	
I_i	A or B input	$V_i = \text{GND to }3.6\text{ V}$	0 V to 3.6 V		0.1	μA
I_{off}		$V_i \text{ or } V_o = 0\text{ V to }3.6\text{ V}$	0 V		0.2	μA
ΔI_{off}		$V_i \text{ or } V_o = 0\text{ V to }3.6\text{ V}$	0 V to 0.2 V		0.2	μA
I_{CC}		$V_i = \text{GND or } (V_{CC} \text{ to } 3.6\text{ V}), I_o = 0$	0.8 V to 3.6 V		0.5	μA
ΔI_{CC}		$V_i = V_{CC} - 0.6\text{ V}^{(1)}, I_o = 0$	3.3 V		40	μA
C_i		$V_i = V_{CC} \text{ or GND}$	0 V	1.5		pF
			3.6 V	1.5		
C_o		$V_o = \text{GND}$	0 V	3		pF

(1) One input at $V_{CC} - 0.6\text{ V}$, other input at V_{CC} or GND

6.6 Electrical Characteristics, $T_A = -40^\circ\text{C}$ to $+85^\circ\text{C}$

over recommended operating free-air temperature range (unless otherwise noted)

PARAMETER		TEST CONDITIONS	V_{CC}	MIN	TYP	MAX	UNIT
V_{OH}		$I_{OH} = -20 \mu\text{A}$	0.8 V to 3.6 V	$V_{CC} - 0.1$			V
		$I_{OH} = -1.1 \text{ mA}$	1.1 V	$0.7 \times V_{CC}$			
		$I_{OH} = -1.7 \text{ mA}$	1.4 V	1.03			
		$I_{OH} = -1.9 \text{ mA}$	1.65 V	1.3			
		$I_{OH} = -2.3 \text{ mA}$	2.3 V	1.97			
		$I_{OH} = -3.1 \text{ mA}$		1.85			
		$I_{OH} = -2.7 \text{ mA}$	3 V	2.67			
		$I_{OH} = -4 \text{ mA}$		2.55			
V_{OL}		$I_{OL} = 20 \mu\text{A}$	0.8 V to 3.6 V			0.1	V
		$I_{OL} = 1.1 \text{ mA}$	1.1 V			$0.3 \times V_{CC}$	
		$I_{OL} = 1.7 \text{ mA}$	1.4 V			0.37	
		$I_{OL} = 1.9 \text{ mA}$	1.65 V			0.35	
		$I_{OL} = 2.3 \text{ mA}$	2.3 V			0.33	
		$I_{OL} = 3.1 \text{ mA}$				0.45	
		$I_{OL} = 2.7 \text{ mA}$	3 V			0.33	
		$I_{OL} = 4 \text{ mA}$				0.45	
I_I	A or B input	$V_I = \text{GND to } 3.6 \text{ V}$	0 V to 3.6 V			0.5	μA
I_{off}		V_I or $V_O = 0 \text{ V to } 3.6 \text{ V}$	0 V			0.6	μA
ΔI_{off}		V_I or $V_O = 0 \text{ V to } 3.6 \text{ V}$	0 V to 0.2 V			0.6	μA
I_{CC}		$V_I = \text{GND or } (V_{CC} \text{ to } 3.6 \text{ V}),$ $I_O = 0$	0.8 V to 3.6 V			0.9	μA
ΔI_{CC}		$V_I = V_{CC} - 0.6 \text{ V}^{(1)}, I_O = 0$	3.3 V			50	μA
C_i		$V_I = V_{CC}$ or GND	0 V				pF
			3.6 V				
C_o		$V_O = \text{GND}$	0 V				pF

 (1) One input at $V_{CC} - 0.6 \text{ V}$, other input at V_{CC} or GND

6.7 Timing Requirements

over recommended operating free-air temperature range (unless otherwise noted) (see [Figure 3](#))

		V _{CC}	MIN ⁽¹⁾	TYP ⁽²⁾	MAX ⁽¹⁾	UNIT
f _{clock}	Clock frequency	0.8 V		21		MHz
		1.2 V ± 0.1 V			40	
		1.5 V ± 0.1 V			50	
		1.8 V ± 0.15 V			60	
		2.5 V ± 0.2 V			90	
		3.3 V ± 0.3 V			90	
t _w	CLK high or low	0.8 V		3.5		ns
		1.2 V ± 0.1 V			2	
		1.5 V ± 0.1 V		2		
		1.8 V ± 0.15 V		2		
		2.5 V ± 0.2 V		2		
		3.3 V ± 0.3 V		2		
	PRE or CLR low	0.8 V		4.5		
		1.2 V ± 0.1 V		2		
		1.5 V ± 0.1 V		2		
		1.8 V ± 0.15 V		2		
		2.5 V ± 0.2 V		2		
		3.3 V ± 0.3 V		2		
t _{su}	Data high	0.8 V		3		ns
		1.2 V ± 0.1 V		1.3		
		1.5 V ± 0.1 V		1		
		1.8 V ± 0.15 V		1		
		2.5 V ± 0.2 V		0.5		
		3.3 V ± 0.3 V		0.5		
	Data low	0.8 V		1		
		1.2 V ± 0.1 V		1.2		
		1.5 V ± 0.1 V		1		
		1.8 V ± 0.15 V		1		
		2.5 V ± 0.2 V		1		
		3.3 V ± 0.3 V		1		
	PRE or CLR inactive	0.8 V		1		
		1.2 V ± 0.1 V		0.5		
		1.5 V ± 0.1 V		0.5		
		1.8 V ± 0.15 V		0.5		
		2.5 V ± 0.2 V		0.5		
		3.3 V ± 0.3 V		0.5		
t _h	Hold time, data after CLK↑	0.8 V		0		ns
		1.2 V ± 0.1 V		0		
		1.5 V ± 0.1 V		0		
		1.8 V ± 0.15 V		0		
		2.5 V ± 0.2 V		0		
		3.3 V ± 0.3 V		0		

(1) Minimum and maximum values are for T_A = –40°C to +85°C

(2) Typicals are for T_A = 25°C

6.8 Switching Characteristics, $C_L = 5 \text{ pF}$

 over recommended operating free-air temperature range, $C_L = 5 \text{ pF}$ (unless otherwise noted) (see [Figure 3](#) and [Figure 4](#))

PARAMETER	FROM (INPUT)	TO (OUTPUT)	V_{CC}	T_A	MIN	TYP	MAX	UNIT
f_{max}			0.8 V	$T_A = 25^\circ\text{C}$	60			MHz
			$1.2 \text{ V} \pm 0.1 \text{ V}$	$T_A = 25^\circ\text{C}$	80			
				$T_A = -40^\circ\text{C to } 85^\circ\text{C}$	60			
			$1.5 \text{ V} \pm 0.1 \text{ V}$	$T_A = 25^\circ\text{C}$	125			
				$T_A = -40^\circ\text{C to } 85^\circ\text{C}$	90			
			$1.8 \text{ V} \pm 0.15 \text{ V}$	$T_A = 25^\circ\text{C}$	150			
				$T_A = -40^\circ\text{C to } 85^\circ\text{C}$	120			
			$2.5 \text{ V} \pm 0.2 \text{ V}$	$T_A = 25^\circ\text{C}$	180			
				$T_A = -40^\circ\text{C to } 85^\circ\text{C}$	160			
			$3.3 \text{ V} \pm 0.3 \text{ V}$	$T_A = 25^\circ\text{C}$	190			
				$T_A = -40^\circ\text{C to } 85^\circ\text{C}$	180			
			t_{pd}	CLK	Q	0.8 V	$T_A = 25^\circ\text{C}$	
$1.2 \text{ V} \pm 0.1 \text{ V}$	$T_A = 25^\circ\text{C}$	2				10	20	
	$T_A = -40^\circ\text{C to } 85^\circ\text{C}$	2.7					20.4	
$1.5 \text{ V} \pm 0.1 \text{ V}$	$T_A = 25^\circ\text{C}$	2				6	12	
	$T_A = -40^\circ\text{C to } 85^\circ\text{C}$	1.9					12.4	
$1.8 \text{ V} \pm 0.15 \text{ V}$	$T_A = 25^\circ\text{C}$	2				5	9	
	$T_A = -40^\circ\text{C to } 85^\circ\text{C}$	1.4				9.5		
$2.5 \text{ V} \pm 0.2 \text{ V}$	$T_A = 25^\circ\text{C}$	2			3	6		
	$T_A = -40^\circ\text{C to } 85^\circ\text{C}$	1.1				6.2		
$3.3 \text{ V} \pm 0.3 \text{ V}$	$T_A = 25^\circ\text{C}$	2			3	4		
	$T_A = -40^\circ\text{C to } 85^\circ\text{C}$	1				4.7		
\bar{Q}	0.8 V	$T_A = 25^\circ\text{C}$			28			
	$1.2 \text{ V} \pm 0.1 \text{ V}$	$T_A = 25^\circ\text{C}$		2	9	19		
		$T_A = -40^\circ\text{C to } 85^\circ\text{C}$		2.4		19		
	$1.5 \text{ V} \pm 0.1 \text{ V}$	$T_A = 25^\circ\text{C}$		2	6	11		
		$T_A = -40^\circ\text{C to } 85^\circ\text{C}$		1.6		11.8		
	$1.8 \text{ V} \pm 0.15 \text{ V}$	$T_A = 25^\circ\text{C}$		2	5	9		
$T_A = -40^\circ\text{C to } 85^\circ\text{C}$		1.3			9			
$2.5 \text{ V} \pm 0.2 \text{ V}$	$T_A = 25^\circ\text{C}$	2		3	6			
	$T_A = -40^\circ\text{C to } 85^\circ\text{C}$	1.1			6			
$3.3 \text{ V} \pm 0.3 \text{ V}$	$T_A = 25^\circ\text{C}$	2		3	4			
	$T_A = -40^\circ\text{C to } 85^\circ\text{C}$	1			4.6			
$\overline{\text{PRE}}$ or $\overline{\text{CLR}}$	Q or \bar{Q}	0.8 V		$T_A = 25^\circ\text{C}$	26			
		$1.2 \text{ V} \pm 0.1 \text{ V}$		$T_A = 25^\circ\text{C}$	2	9	20	
			$T_A = -40^\circ\text{C to } 85^\circ\text{C}$	2		20		
		$1.5 \text{ V} \pm 0.1 \text{ V}$	$T_A = 25^\circ\text{C}$	2	6	12		
			$T_A = -40^\circ\text{C to } 85^\circ\text{C}$	1.5		13		
		$1.8 \text{ V} \pm 0.15 \text{ V}$	$T_A = 25^\circ\text{C}$	2	5	9		
			$T_A = -40^\circ\text{C to } 85^\circ\text{C}$	1.3		10		
		$2.5 \text{ V} \pm 0.2 \text{ V}$	$T_A = 25^\circ\text{C}$	2	3	6		
			$T_A = -40^\circ\text{C to } 85^\circ\text{C}$	1		7		
		$3.3 \text{ V} \pm 0.3 \text{ V}$	$T_A = 25^\circ\text{C}$	2	3	5		
			$T_A = -40^\circ\text{C to } 85^\circ\text{C}$	1		5		

6.9 Switching Characteristics, $C_L = 10$ pF

 over recommended operating free-air temperature range, $C_L = 10$ pF (unless otherwise noted) (see [Figure 3](#) and [Figure 4](#))

PARAMETER	FROM (INPUT)	TO (OUTPUT)	V_{CC}	T_A	MIN	TYP	MAX	UNIT
f_{max}			0.8 V	$T_A = 25^\circ\text{C}$		46		MHz
			$1.2\text{ V} \pm 0.1\text{ V}$	$T_A = 25^\circ\text{C}$		65		
				$T_A = -40^\circ\text{C to } 85^\circ\text{C}$	50			
			$1.5\text{ V} \pm 0.1\text{ V}$	$T_A = 25^\circ\text{C}$		95		
				$T_A = -40^\circ\text{C to } 85^\circ\text{C}$	55			
			$1.8\text{ V} \pm 0.15\text{ V}$	$T_A = 25^\circ\text{C}$		110		
				$T_A = -40^\circ\text{C to } 85^\circ\text{C}$	60			
			$2.5\text{ V} \pm 0.2\text{ V}$	$T_A = 25^\circ\text{C}$		170		
				$T_A = -40^\circ\text{C to } 85^\circ\text{C}$	130			
			$3.3\text{ V} \pm 0.3\text{ V}$	$T_A = 25^\circ\text{C}$		180		
				$T_A = -40^\circ\text{C to } 85^\circ\text{C}$	160			
			t_{pd}	CLK	Q	0.8 V	$T_A = 25^\circ\text{C}$	
$1.2\text{ V} \pm 0.1\text{ V}$	$T_A = 25^\circ\text{C}$	2				10	22	
	$T_A = -40^\circ\text{C to } 85^\circ\text{C}$	3.4					21.8	
$1.5\text{ V} \pm 0.1\text{ V}$	$T_A = 25^\circ\text{C}$	2				7	13	
	$T_A = -40^\circ\text{C to } 85^\circ\text{C}$	2.4					13.5	
$1.8\text{ V} \pm 0.15\text{ V}$	$T_A = 25^\circ\text{C}$	2				6	10	
	$T_A = -40^\circ\text{C to } 85^\circ\text{C}$	1.9				10.4		
$2.5\text{ V} \pm 0.2\text{ V}$	$T_A = 25^\circ\text{C}$	2			4	6		
	$T_A = -40^\circ\text{C to } 85^\circ\text{C}$	1.5				7		
$3.3\text{ V} \pm 0.3\text{ V}$	$T_A = 25^\circ\text{C}$	2			3	5		
	$T_A = -40^\circ\text{C to } 85^\circ\text{C}$	1.2				5.3		
\bar{Q}	0.8 V	$T_A = 25^\circ\text{C}$				30		
	$1.2\text{ V} \pm 0.1\text{ V}$	$T_A = 25^\circ\text{C}$		2	10	20		
		$T_A = -40^\circ\text{C to } 85^\circ\text{C}$		3		20.3		
	$1.5\text{ V} \pm 0.1\text{ V}$	$T_A = 25^\circ\text{C}$		2	7	12		
		$T_A = -40^\circ\text{C to } 85^\circ\text{C}$		2.2		12.8		
	$1.8\text{ V} \pm 0.15\text{ V}$	$T_A = 25^\circ\text{C}$		2	5	9		
$T_A = -40^\circ\text{C to } 85^\circ\text{C}$		1.8			9.9			
$2.5\text{ V} \pm 0.2\text{ V}$	$T_A = 25^\circ\text{C}$	2		4	6			
	$T_A = -40^\circ\text{C to } 85^\circ\text{C}$	1.3			6.7			
$3.3\text{ V} \pm 0.3\text{ V}$	$T_A = 25^\circ\text{C}$	2		3	5			
	$T_A = -40^\circ\text{C to } 85^\circ\text{C}$	1.1			5.2			
$\overline{\text{PRE}}$ or $\overline{\text{CLR}}$	Q or \bar{Q}	0.8 V		$T_A = 25^\circ\text{C}$		29		
		$1.2\text{ V} \pm 0.1\text{ V}$		$T_A = 25^\circ\text{C}$	2	10	21	
			$T_A = -40^\circ\text{C to } 85^\circ\text{C}$	2		21.4		
		$1.5\text{ V} \pm 0.1\text{ V}$	$T_A = 25^\circ\text{C}$	2	7	13		
			$T_A = -40^\circ\text{C to } 85^\circ\text{C}$	2		13.8		
		$1.8\text{ V} \pm 0.15\text{ V}$	$T_A = 25^\circ\text{C}$	2	5	10		
			$T_A = -40^\circ\text{C to } 85^\circ\text{C}$	2		10.8		
		$2.5\text{ V} \pm 0.2\text{ V}$	$T_A = 25^\circ\text{C}$	2	4	7		
			$T_A = -40^\circ\text{C to } 85^\circ\text{C}$	1.5		7.4		
		$3.3\text{ V} \pm 0.3\text{ V}$	$T_A = 25^\circ\text{C}$	2	3	5		
			$T_A = -40^\circ\text{C to } 85^\circ\text{C}$	1.5		5.8		

6.10 Switching Characteristics, $C_L = 15\text{ pF}$

over recommended operating free-air temperature range, $C_L = 15\text{ pF}$ (unless otherwise noted) (see Figure 3 and Figure 4)

PARAMETER	FROM (INPUT)	TO (OUTPUT)	V_{CC}	T_A	MIN	TYP	MAX	UNIT	
f_{max}			0.8 V	$T_A = 25^\circ\text{C}$		41		MHz	
			$1.2\text{ V} \pm 0.1\text{ V}$	$T_A = 25^\circ\text{C}$		75			
				$T_A = -40^\circ\text{C to } 85^\circ\text{C}$		50			
			$1.5\text{ V} \pm 0.1\text{ V}$	$T_A = 25^\circ\text{C}$		95			
				$T_A = -40^\circ\text{C to } 85^\circ\text{C}$		55			
			$1.8\text{ V} \pm 0.15\text{ V}$	$T_A = 25^\circ\text{C}$		100			
				$T_A = -40^\circ\text{C to } 85^\circ\text{C}$		60			
			$2.5\text{ V} \pm 0.2\text{ V}$	$T_A = 25^\circ\text{C}$		150			
				$T_A = -40^\circ\text{C to } 85^\circ\text{C}$		130			
			$3.3\text{ V} \pm 0.3\text{ V}$	$T_A = 25^\circ\text{C}$		200			
				$T_A = -40^\circ\text{C to } 85^\circ\text{C}$		160			
			t_{pd}	CLK	Q	0.8 V	$T_A = 25^\circ\text{C}$		
$1.2\text{ V} \pm 0.1\text{ V}$	$T_A = 25^\circ\text{C}$					2	12	23.1	
	$T_A = -40^\circ\text{C to } 85^\circ\text{C}$					4.1		23.2	
$1.5\text{ V} \pm 0.1\text{ V}$	$T_A = 25^\circ\text{C}$					2	8	14.1	
	$T_A = -40^\circ\text{C to } 85^\circ\text{C}$					2.9		14.6	
$1.8\text{ V} \pm 0.15\text{ V}$	$T_A = 25^\circ\text{C}$					2	6	10.7	
	$T_A = -40^\circ\text{C to } 85^\circ\text{C}$				2.4		11.3		
$2.5\text{ V} \pm 0.2\text{ V}$	$T_A = 25^\circ\text{C}$				2	4	7		
	$T_A = -40^\circ\text{C to } 85^\circ\text{C}$				1.9		7.6		
$3.3\text{ V} \pm 0.3\text{ V}$	$T_A = 25^\circ\text{C}$				2	4	5.4		
	$T_A = -40^\circ\text{C to } 85^\circ\text{C}$				1.6		5.9		
\bar{Q}	0.8 V	$T_A = 25^\circ\text{C}$				32			
	$1.2\text{ V} \pm 0.1\text{ V}$	$T_A = 25^\circ\text{C}$			2	11	21.8		
		$T_A = -40^\circ\text{C to } 85^\circ\text{C}$			3.7		21.8		
	$1.5\text{ V} \pm 0.1\text{ V}$	$T_A = 25^\circ\text{C}$			2	7	13.5		
		$T_A = -40^\circ\text{C to } 85^\circ\text{C}$			2.6		14		
	$1.8\text{ V} \pm 0.15\text{ V}$	$T_A = 25^\circ\text{C}$			2	6	10.4		
$T_A = -40^\circ\text{C to } 85^\circ\text{C}$				2.2		10.9			
$2.5\text{ V} \pm 0.2\text{ V}$	$T_A = 25^\circ\text{C}$			2	4	7.1			
	$T_A = -40^\circ\text{C to } 85^\circ\text{C}$			1.7		7.5			
$3.3\text{ V} \pm 0.3\text{ V}$	$T_A = 25^\circ\text{C}$			2	3	5.4			
	$T_A = -40^\circ\text{C to } 85^\circ\text{C}$			1.4		5.8			
$\overline{\text{PRE}}$ or $\overline{\text{CLR}}$	Q or \bar{Q}	0.8 V		$T_A = 25^\circ\text{C}$		31			
		$1.2\text{ V} \pm 0.1\text{ V}$		$T_A = 25^\circ\text{C}$		2	11	23	
			$T_A = -40^\circ\text{C to } 85^\circ\text{C}$		2		22.9		
		$1.5\text{ V} \pm 0.1\text{ V}$	$T_A = 25^\circ\text{C}$		2	7	14		
			$T_A = -40^\circ\text{C to } 85^\circ\text{C}$		2		14.9		
		$1.8\text{ V} \pm 0.15\text{ V}$	$T_A = 25^\circ\text{C}$		2	6	11		
			$T_A = -40^\circ\text{C to } 85^\circ\text{C}$		2		11.7		
		$2.5\text{ V} \pm 0.2\text{ V}$	$T_A = 25^\circ\text{C}$		2	4	7		
			$T_A = -40^\circ\text{C to } 85^\circ\text{C}$		2		8.1		
		$3.3\text{ V} \pm 0.3\text{ V}$	$T_A = 25^\circ\text{C}$		2	4	6		
			$T_A = -40^\circ\text{C to } 85^\circ\text{C}$		1.5		6.4		

6.11 Switching Characteristics, $C_L = 30$ pF

 over recommended operating free-air temperature range, $C_L = 30$ pF (unless otherwise noted) (see [Figure 3](#) and [Figure 4](#))

PARAMETER	FROM (INPUT)	TO (OUTPUT)	V_{CC}	T_A	MIN	TYP	MAX	UNIT
f_{max}			0.8 V	$T_A = 25^\circ\text{C}$		21		MHz
			$1.2\text{ V} \pm 0.1\text{ V}$	$T_A = 25^\circ\text{C}$		50		
				$T_A = -40^\circ\text{C to } 85^\circ\text{C}$	40			
			$1.5\text{ V} \pm 0.1\text{ V}$	$T_A = 25^\circ\text{C}$		60		
				$T_A = -40^\circ\text{C to } 85^\circ\text{C}$	50			
			$1.8\text{ V} \pm 0.15\text{ V}$	$T_A = 25^\circ\text{C}$		75		
				$T_A = -40^\circ\text{C to } 85^\circ\text{C}$	70			
			$2.5\text{ V} \pm 0.2\text{ V}$	$T_A = 25^\circ\text{C}$		100		
				$T_A = -40^\circ\text{C to } 85^\circ\text{C}$	90			
			$3.3\text{ V} \pm 0.3\text{ V}$	$T_A = 25^\circ\text{C}$		100		
				$T_A = -40^\circ\text{C to } 85^\circ\text{C}$	90			
			t_{pd}	CLK	Q	0.8 V	$T_A = 25^\circ\text{C}$	
$1.2\text{ V} \pm 0.1\text{ V}$	$T_A = 25^\circ\text{C}$	3				14	27	
	$T_A = -40^\circ\text{C to } 85^\circ\text{C}$	5.9					27	
$1.5\text{ V} \pm 0.1\text{ V}$	$T_A = 25^\circ\text{C}$	3				10	17	
	$T_A = -40^\circ\text{C to } 85^\circ\text{C}$	4.4					17.2	
$1.8\text{ V} \pm 0.15\text{ V}$	$T_A = 25^\circ\text{C}$	3				8	13	
	$T_A = -40^\circ\text{C to } 85^\circ\text{C}$	3.6				13.4		
$2.5\text{ V} \pm 0.2\text{ V}$	$T_A = 25^\circ\text{C}$	3			6	9		
	$T_A = -40^\circ\text{C to } 85^\circ\text{C}$	3				9.2		
$3.3\text{ V} \pm 0.3\text{ V}$	$T_A = 25^\circ\text{C}$	3			5	7		
	$T_A = -40^\circ\text{C to } 85^\circ\text{C}$	2.6				7.2		
\bar{Q}	0.8 V	$T_A = 25^\circ\text{C}$				40		
	$1.2\text{ V} \pm 0.1\text{ V}$	$T_A = 25^\circ\text{C}$		3	13	26		
		$T_A = -40^\circ\text{C to } 85^\circ\text{C}$		5.5		25.9		
	$1.5\text{ V} \pm 0.1\text{ V}$	$T_A = 25^\circ\text{C}$		3	9	16		
		$T_A = -40^\circ\text{C to } 85^\circ\text{C}$		4.1		16.8		
	$1.8\text{ V} \pm 0.15\text{ V}$	$T_A = 25^\circ\text{C}$		3	7	13		
$T_A = -40^\circ\text{C to } 85^\circ\text{C}$		3.5			13.2			
$2.5\text{ V} \pm 0.2\text{ V}$	$T_A = 25^\circ\text{C}$	3		5	9			
	$T_A = -40^\circ\text{C to } 85^\circ\text{C}$	2.7			9.2			
$3.3\text{ V} \pm 0.3\text{ V}$	$T_A = 25^\circ\text{C}$	3		5	7			
	$T_A = -40^\circ\text{C to } 85^\circ\text{C}$	2.4			7.2			
$\overline{\text{PRE}}$ or $\overline{\text{CLR}}$	Q or \bar{Q}	0.8 V		$T_A = 25^\circ\text{C}$		38		
		$1.2\text{ V} \pm 0.1\text{ V}$		$T_A = 25^\circ\text{C}$	3	13	26	
			$T_A = -40^\circ\text{C to } 85^\circ\text{C}$	3		27		
		$1.5\text{ V} \pm 0.1\text{ V}$	$T_A = 25^\circ\text{C}$	3	9	17		
			$T_A = -40^\circ\text{C to } 85^\circ\text{C}$	3		17.4		
		$1.8\text{ V} \pm 0.15\text{ V}$	$T_A = 25^\circ\text{C}$	3	8	13		
			$T_A = -40^\circ\text{C to } 85^\circ\text{C}$	3		14		
		$2.5\text{ V} \pm 0.2\text{ V}$	$T_A = 25^\circ\text{C}$	3	6	9		
			$T_A = -40^\circ\text{C to } 85^\circ\text{C}$	3		10		
		$3.3\text{ V} \pm 0.3\text{ V}$	$T_A = 25^\circ\text{C}$	3	5	7		
			$T_A = -40^\circ\text{C to } 85^\circ\text{C}$	2.5		8		

SN74AUP1G74

SCES644D – MARCH 2006 – REVISED DECEMBER 2015

www.ti.com
6.12 Operating Characteristics
 $T_A = 25^\circ\text{C}$

PARAMETER	TEST CONDITIONS	V_{CC}	TYP	UNIT
C_{pd} Power dissipation capacitance	$f = 10 \text{ MHz}$	0.8 V	5.5	μF
		$1.2 \text{ V} \pm 0.1 \text{ V}$	5.5	
		$1.5 \text{ V} \pm 0.1 \text{ V}$	5.5	
		$1.8 \text{ V} \pm 0.15 \text{ V}$	5.5	
		$2.5 \text{ V} \pm 0.2 \text{ V}$	5.5	
		$3.3 \text{ V} \pm 0.3 \text{ V}$	5.5	

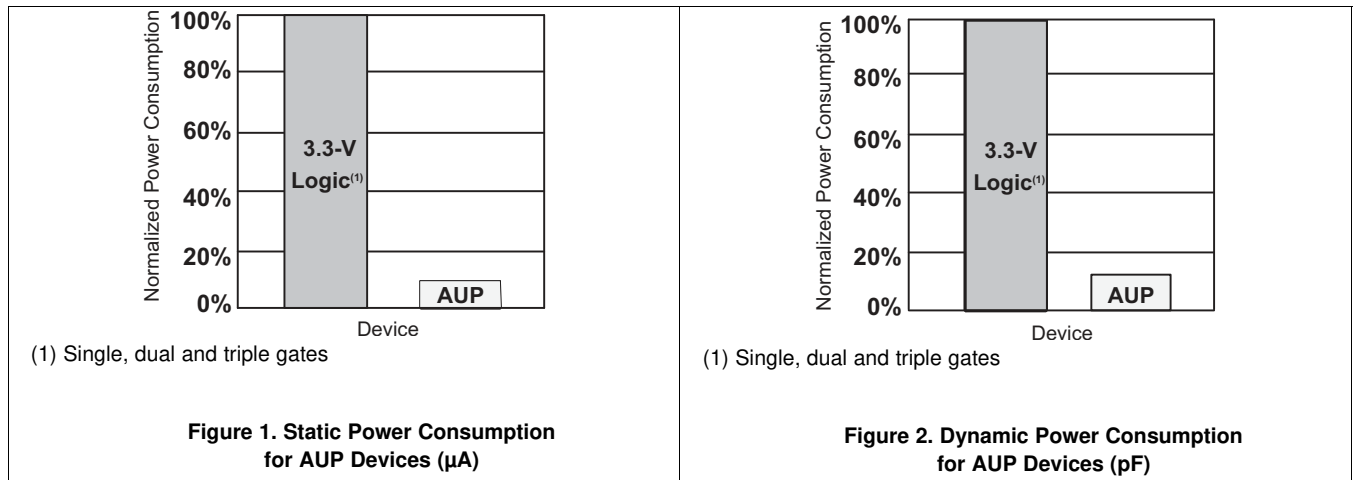
6.13 Typical Characteristics

7 Parameter Measurement Information

7.1 Propagation Delays, Setup and Hold Times, and Pulse Width

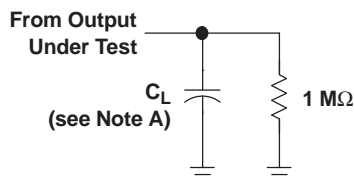

LOAD CIRCUIT

	$V_{CC} = 0.8\text{ V}$	$V_{CC} = 1.2\text{ V} \pm 0.1\text{ V}$	$V_{CC} = 1.5\text{ V} \pm 0.1\text{ V}$	$V_{CC} = 1.8\text{ V} \pm 0.15\text{ V}$	$V_{CC} = 2.5\text{ V} \pm 0.2\text{ V}$	$V_{CC} = 3.3\text{ V} \pm 0.3\text{ V}$
C_L	5, 10, 15, 30 pF	5, 10, 15, 30 pF	5, 10, 15, 30 pF	5, 10, 15, 30 pF	5, 10, 15, 30 pF	5, 10, 15, 30 pF
V_M	$V_{CC}/2$	$V_{CC}/2$	$V_{CC}/2$	$V_{CC}/2$	$V_{CC}/2$	$V_{CC}/2$
V_I	V_{CC}	V_{CC}	V_{CC}	V_{CC}	V_{CC}	V_{CC}

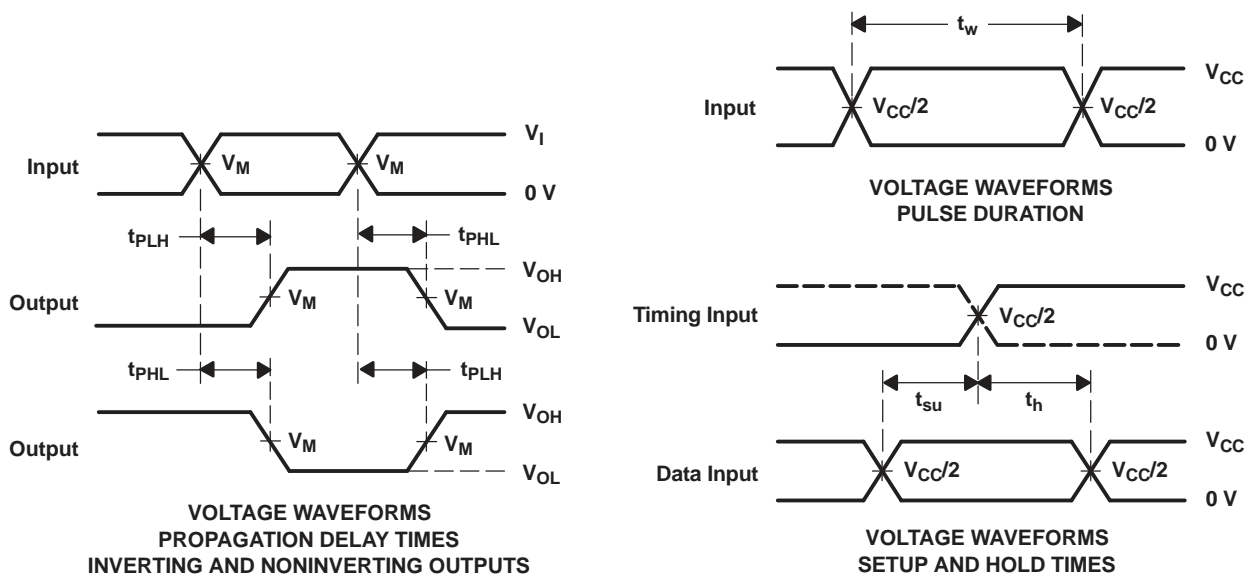

- NOTES:
- A. C_L includes probe and jig capacitance.
 - B. All input pulses are supplied by generators having the following characteristics: $PRR \leq 10\text{ MHz}$, $Z_O = 50\ \Omega$, $t_r/t_f = 3\text{ ns}$.
 - C. The outputs are measured one at a time, with one transition per measurement.
 - D. t_{PLH} and t_{PHL} are the same as t_{pd} .
 - E. All parameters and waveforms are not applicable to all devices.

Figure 3. Load Circuit and Voltage Waveforms

7.2 Enable and Disable Times

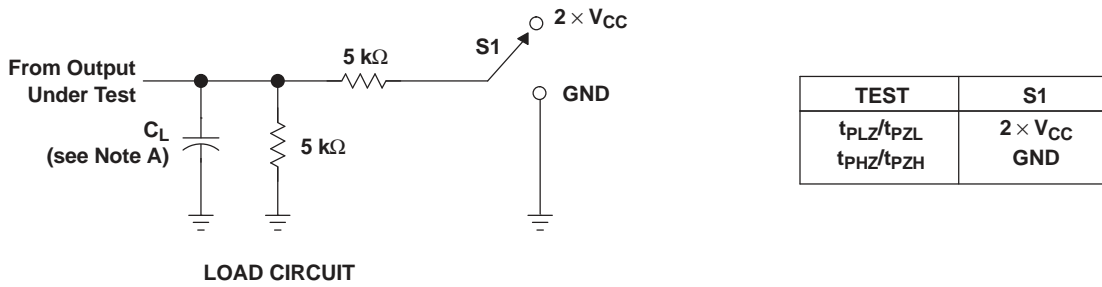

	$V_{CC} = 0.8 \text{ V}$	$V_{CC} = 1.2 \text{ V}$ $\pm 0.1 \text{ V}$	$V_{CC} = 1.5 \text{ V}$ $\pm 0.1 \text{ V}$	$V_{CC} = 1.8 \text{ V}$ $\pm 0.15 \text{ V}$	$V_{CC} = 2.5 \text{ V}$ $\pm 0.2 \text{ V}$	$V_{CC} = 3.3 \text{ V}$ $\pm 0.3 \text{ V}$
C_L	5, 10, 15, 30 pF	5, 10, 15, 30 pF	5, 10, 15, 30 pF	5, 10, 15, 30 pF	5, 10, 15, 30 pF	5, 10, 15, 30 pF
V_M	$V_{CC}/2$	$V_{CC}/2$	$V_{CC}/2$	$V_{CC}/2$	$V_{CC}/2$	$V_{CC}/2$
V_I	V_{CC}	V_{CC}	V_{CC}	V_{CC}	V_{CC}	V_{CC}
V_{Δ}	0.1 V	0.1 V	0.1 V	0.15 V	0.15 V	0.3 V

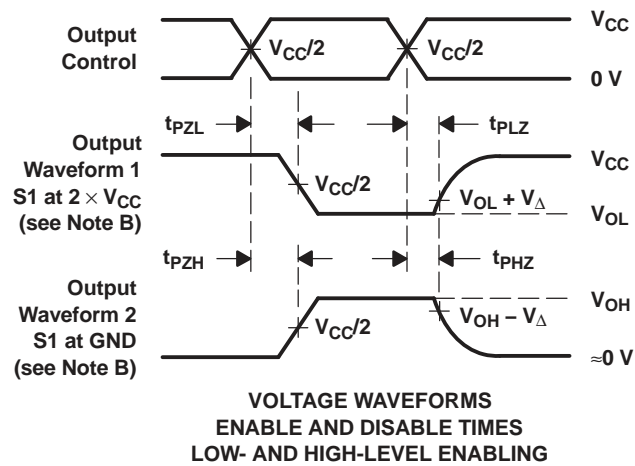

- NOTES:
- C_L includes probe and jig capacitance.
 - Waveform 1 is for an output with internal conditions such that the output is low, except when disabled by the output control. Waveform 2 is for an output with internal conditions such that the output is high, except when disabled by the output control.
 - All input pulses are supplied by generators having the following characteristics: $PRR \leq 10 \text{ MHz}$, $Z_O = 50 \Omega$, $t_r/t_f = 3 \text{ ns}$.
 - The outputs are measured one at a time, with one transition per measurement.
 - t_{PLZ} and t_{PHZ} are the same as t_{dis} .
 - t_{PZL} and t_{PZH} are the same as t_{en} .
 - All parameters and waveforms are not applicable to all devices.

Figure 4. Load Circuit and Voltage Waveforms

8 Detailed Description

8.1 Overview

This single positive-edge-triggered D-type flip-flop is designed for 0.8-V to 3.6-V V_{CC} operation.

A low level at the preset (\overline{PRE}) or clear (\overline{CLR}) input sets or resets the outputs, regardless of the levels of the other inputs. When \overline{PRE} and \overline{CLR} are inactive (high), data at the data (D) input meeting the setup time requirements is transferred to the outputs on the positive-going edge of the clock pulse. Clock triggering occurs at a voltage level and is not related directly to the rise time of the clock pulse. Following the hold-time interval, data at the D input can be changed without affecting the levels at the outputs. When both the CLR and PRE inputs are set low, the CLR input will override the PRE input.

NanoStar package technology is a major breakthrough in IC packaging concepts, using the die as the package.

This device is fully specified for partial-power-down applications using I_{off} . The I_{off} circuitry disables the outputs, preventing damaging current backflow through the device when it is powered down.

8.2 Functional Block Diagram

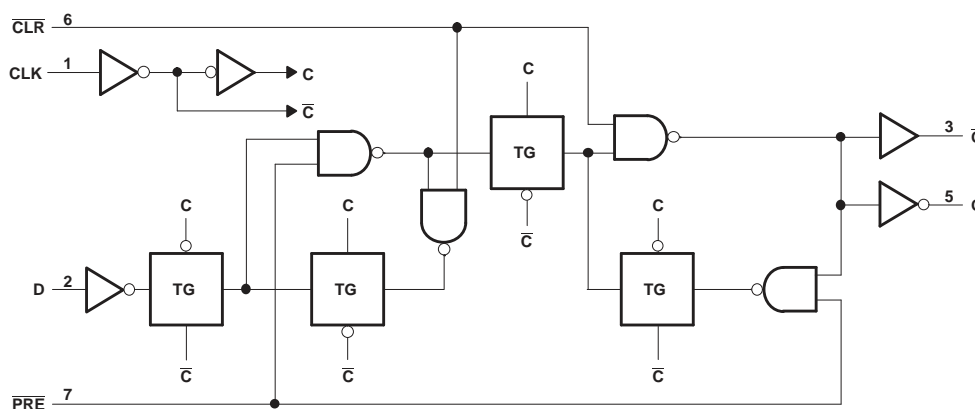

Pin numbers shown are for the DCU and DQE packages

8.3 Feature Description

This device is available in the Texas Instrument's NanoStar package. It has low static-power consumption of 0.9 μ A maximum. It has low noise with overshoot and undershoot at less than ten percent of V_{CC} . It supports partial-power-down mode operation, which is specified by I_{off} . The Schmitt-trigger inputs allow for slow or noisy input signals. The device has a wide operating voltage range of 0.8 V to 3.6 V, and is optimized for 3.3 V. It has low propagation delay of 5 ns maximum at 3.3 V.

8.4 Device Functional Modes

Table 1 lists the functional modes of the SN74AUP1G74.

Table 1. Function Table

INPUTS				OUTPUTS	
PRE	\overline{CLR}	CLK	D	Q	\overline{Q}
L	H	X	X	H	L
X	L	X	X	L	H
H	H	\uparrow	H	H	L
H	H	\uparrow	L	L	H
H	H	L	X	Q_0	\overline{Q}_0

9 Application and Implementation

NOTE

Information in the following applications sections is not part of the TI component specification, and TI does not warrant its accuracy or completeness. TI's customers are responsible for determining suitability of components for their purposes. Customers should validate and test their design implementation to confirm system functionality.

9.1 Application Information

The SN74AUP1G74 can be used to control a power button input. Tying \bar{Q} to D will switch the output between high and low each time that a high signal is sent to CLK from the push button.

A low level at the preset (\overline{PRE}) or clear (\overline{CLR}) input sets or resets the outputs, regardless of the levels of the other inputs. When PRE and CLR are inactive (high), data at the data (D) input meeting the setup time requirements is transferred to the outputs on the positive-going edge of the clock pulse. Clock triggering occurs at a voltage level and is not related directly to the rise time of the clock pulse. Following the hold-time interval, data at the D input can be changed without affecting the levels at the outputs.

The resistor and capacitor at the \overline{CLR} pin are optional. If they are not used, the \overline{CLR} pin must be connected directly to V_{CC} to be inactive.

9.2 Typical Power Button Circuit

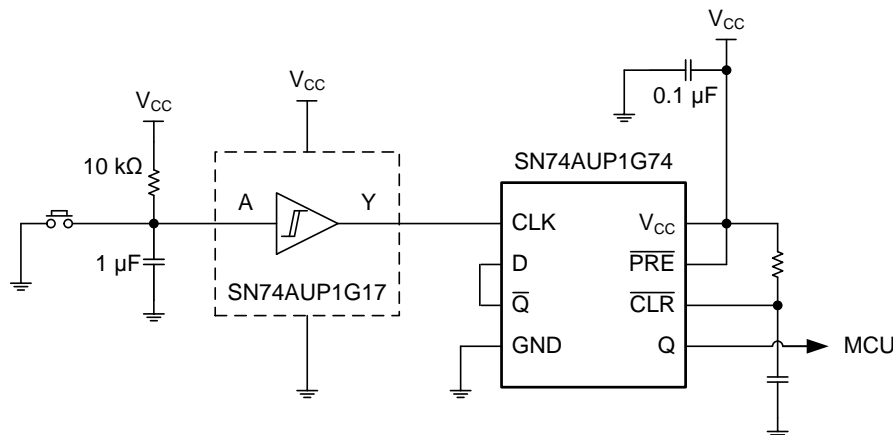

Figure 5. Device Power Button Circuit

9.2.1 Design Requirements

This device uses CMOS technology and has balanced output drive. Take care to avoid bus contention because it can drive currents that would exceed maximum limits. Outputs can be combined to produce higher drive but the high drive will also create faster edges into light loads so routing and load conditions must be considered to prevent ringing.

9.2.2 Detailed Design Procedure

1. Recommended Input Conditions:
 - For rise time and fall time specifications, see $(\Delta t/\Delta V)$ in [Recommended Operating Conditions](#).
 - For specified high and low levels, see $(V_{IH}$ and $V_{IL})$ in [Recommended Operating Conditions](#).
 - Inputs are overvoltage tolerant allowing them to go as high as 4.6 V at any valid V_{CC} .
2. Recommend Output Conditions:
 - Series resistors on the output may be used if the user desires to slow the output edge signal or limit the output current.

Typical Power Button Circuit (continued)

9.2.3 Application Curve

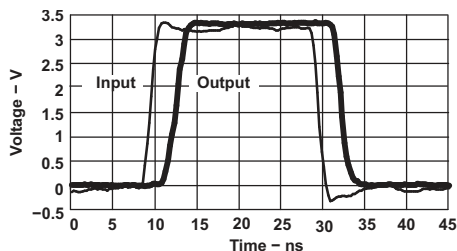

AUP1G08 data at $C_L = 15$ pF

Figure 6. Switching Characteristics at 25 MHz

10 Power Supply Recommendations

The power supply can be any voltage between the minimum and maximum supply voltage rating located in [Recommended Operating Conditions](#).

Each V_{CC} pin must have a good bypass capacitor to prevent power disturbance. For devices with a single supply, TI recommends a 0.1- μ F capacitor, and if there are multiple V_{CC} pins, then TI recommends a 0.01- μ F or 0.022- μ F capacitor for each power pin. It is ok to parallel multiple bypass caps to reject different frequencies of noise. 0.1- μ F and 1- μ F capacitors are commonly used in parallel. The bypass capacitor must be installed as close to the power pin as possible for best results.

11 Layout

11.1 Layout Guidelines

When using multiple bit logic devices inputs must not ever float. In many cases, functions or parts of functions of digital logic devices are unused; for example, when only two inputs of a triple-input AND gate are used or only 3 of the 4 buffer gates are used. Such input pins must not be left unconnected because the undefined voltages at the outside connections result in undefined operational states. Specified below are the rules that must be observed under all circumstances. All unused inputs of digital logic devices must be connected to a high or low bias to prevent them from floating. The logic level that must be applied to any particular unused input depends on the function of the device. Generally they will be tied to GND or V_{CC} whichever make more sense or is more convenient.

11.2 Layout Example

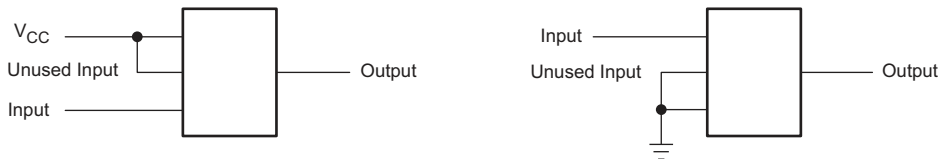

Figure 7. Layout Diagram

12 Device and Documentation Support

12.1 Documentation Support

12.1.1 Related Documentation

For related documentation, see the following:

Implications of Slow or Floating CMOS Inputs, [SCBA004](#)

12.2 Community Resources

The following links connect to TI community resources. Linked contents are provided "AS IS" by the respective contributors. They do not constitute TI specifications and do not necessarily reflect TI's views; see TI's [Terms of Use](#).

TI E2E™ Online Community *TI's Engineer-to-Engineer (E2E) Community*. Created to foster collaboration among engineers. At [e2e.ti.com](#), you can ask questions, share knowledge, explore ideas and help solve problems with fellow engineers.

Design Support *TI's Design Support* Quickly find helpful E2E forums along with design support tools and contact information for technical support.

12.3 Trademarks

NanoStar, E2E are trademarks of Texas Instruments.
All other trademarks are the property of their respective owners.

12.4 Electrostatic Discharge Caution



These devices have limited built-in ESD protection. The leads should be shorted together or the device placed in conductive foam during storage or handling to prevent electrostatic damage to the MOS gates.

12.5 Glossary

[SLYZ022](#) — *TI Glossary*.

This glossary lists and explains terms, acronyms, and definitions.

13 Mechanical, Packaging, and Orderable Information

The following pages include mechanical packaging and orderable information. This information is the most current data available for the designated devices. This data is subject to change without notice and revision of this document. For browser based versions of this data sheet, refer to the left hand navigation.

PACKAGING INFORMATION

Orderable Device	Status (1)	Package Type	Package Drawing	Pins	Package Qty	Eco Plan (2)	Lead finish/ Ball material (6)	MSL Peak Temp (3)	Op Temp (°C)	Device Marking (4/5)	Samples
SN74AUP1G74DCUR	ACTIVE	VSSOP	DCU	8	3000	RoHS & Green	NIPDAU	Level-1-260C-UNLIM	-40 to 85	H74R	Samples
SN74AUP1G74DCURG4	ACTIVE	VSSOP	DCU	8	3000	RoHS & Green	NIPDAU	Level-1-260C-UNLIM	-40 to 85	H74R	Samples
SN74AUP1G74DQER	ACTIVE	X2SON	DQE	8	5000	RoHS & Green	NIPDAUAG	Level-1-260C-UNLIM	-40 to 85	HS	Samples
SN74AUP1G74RSER	ACTIVE	UQFN	RSE	8	5000	RoHS & Green	NIPDAUAG	Level-1-260C-UNLIM	-40 to 85	HS	Samples
SN74AUP1G74YFPR	ACTIVE	DSBGA	YFP	8	3000	RoHS & Green	SNAGCU	Level-1-260C-UNLIM	-40 to 85	HSN	Samples
SN74AUP1G74YZPR	ACTIVE	DSBGA	YZP	8	3000	RoHS & Green	SNAGCU	Level-1-260C-UNLIM	-40 to 85	HSN	Samples

(1) The marketing status values are defined as follows:

ACTIVE: Product device recommended for new designs.

LIFEBUY: TI has announced that the device will be discontinued, and a lifetime-buy period is in effect.

NRND: Not recommended for new designs. Device is in production to support existing customers, but TI does not recommend using this part in a new design.

PREVIEW: Device has been announced but is not in production. Samples may or may not be available.

OBSOLETE: TI has discontinued the production of the device.

(2) **RoHS:** TI defines "RoHS" to mean semiconductor products that are compliant with the current EU RoHS requirements for all 10 RoHS substances, including the requirement that RoHS substance do not exceed 0.1% by weight in homogeneous materials. Where designed to be soldered at high temperatures, "RoHS" products are suitable for use in specified lead-free processes. TI may reference these types of products as "Pb-Free".

RoHS Exempt: TI defines "RoHS Exempt" to mean products that contain lead but are compliant with EU RoHS pursuant to a specific EU RoHS exemption.

Green: TI defines "Green" to mean the content of Chlorine (Cl) and Bromine (Br) based flame retardants meet JS709B low halogen requirements of <=1000ppm threshold. Antimony trioxide based flame retardants must also meet the <=1000ppm threshold requirement.

(3) MSL, Peak Temp. - The Moisture Sensitivity Level rating according to the JEDEC industry standard classifications, and peak solder temperature.

(4) There may be additional marking, which relates to the logo, the lot trace code information, or the environmental category on the device.

(5) Multiple Device Markings will be inside parentheses. Only one Device Marking contained in parentheses and separated by a "~" will appear on a device. If a line is indented then it is a continuation of the previous line and the two combined represent the entire Device Marking for that device.

(6) Lead finish/Ball material - Orderable Devices may have multiple material finish options. Finish options are separated by a vertical ruled line. Lead finish/Ball material values may wrap to two lines if the finish value exceeds the maximum column width.

Important Information and Disclaimer: The information provided on this page represents TI's knowledge and belief as of the date that it is provided. TI bases its knowledge and belief on information provided by third parties, and makes no representation or warranty as to the accuracy of such information. Efforts are underway to better integrate information from third parties. TI has taken and continues to take reasonable steps to provide representative and accurate information but may not have conducted destructive testing or chemical analysis on incoming materials and chemicals. TI and TI suppliers consider certain information to be proprietary, and thus CAS numbers and other limited information may not be available for release.

In no event shall TI's liability arising out of such information exceed the total purchase price of the TI part(s) at issue in this document sold by TI to Customer on an annual basis.

TAPE AND REEL INFORMATION



QUADRANT ASSIGNMENTS FOR PIN 1 ORIENTATION IN TAPE



*All dimensions are nominal

Device	Package Type	Package Drawing	Pins	SPQ	Reel Diameter (mm)	Reel Width W1 (mm)	A0 (mm)	B0 (mm)	K0 (mm)	P1 (mm)	W (mm)	Pin1 Quadrant
SN74AUP1G74DCUR	VSSOP	DCU	8	3000	180.0	8.4	2.25	3.35	1.05	4.0	8.0	Q3
SN74AUP1G74DQER	X2SON	DQE	8	5000	180.0	8.4	1.2	1.6	0.55	4.0	8.0	Q1
SN74AUP1G74RSER	UQFN	RSE	8	5000	180.0	8.4	1.7	1.7	0.7	4.0	8.0	Q2
SN74AUP1G74YFPR	DSBGA	YFP	8	3000	178.0	9.2	0.9	1.75	0.6	4.0	8.0	Q1
SN74AUP1G74YZPR	DSBGA	YZP	8	3000	178.0	9.2	1.02	2.02	0.63	4.0	8.0	Q1

TAPE AND REEL BOX DIMENSIONS

*All dimensions are nominal

Device	Package Type	Package Drawing	Pins	SPQ	Length (mm)	Width (mm)	Height (mm)
SN74AUP1G74DCUR	VSSOP	DCU	8	3000	202.0	201.0	28.0
SN74AUP1G74DQER	X2SON	DQE	8	5000	202.0	201.0	28.0
SN74AUP1G74RSER	UQFN	RSE	8	5000	202.0	201.0	28.0
SN74AUP1G74YFPR	DSBGA	YFP	8	3000	220.0	220.0	35.0
SN74AUP1G74YZPR	DSBGA	YZP	8	3000	220.0	220.0	35.0

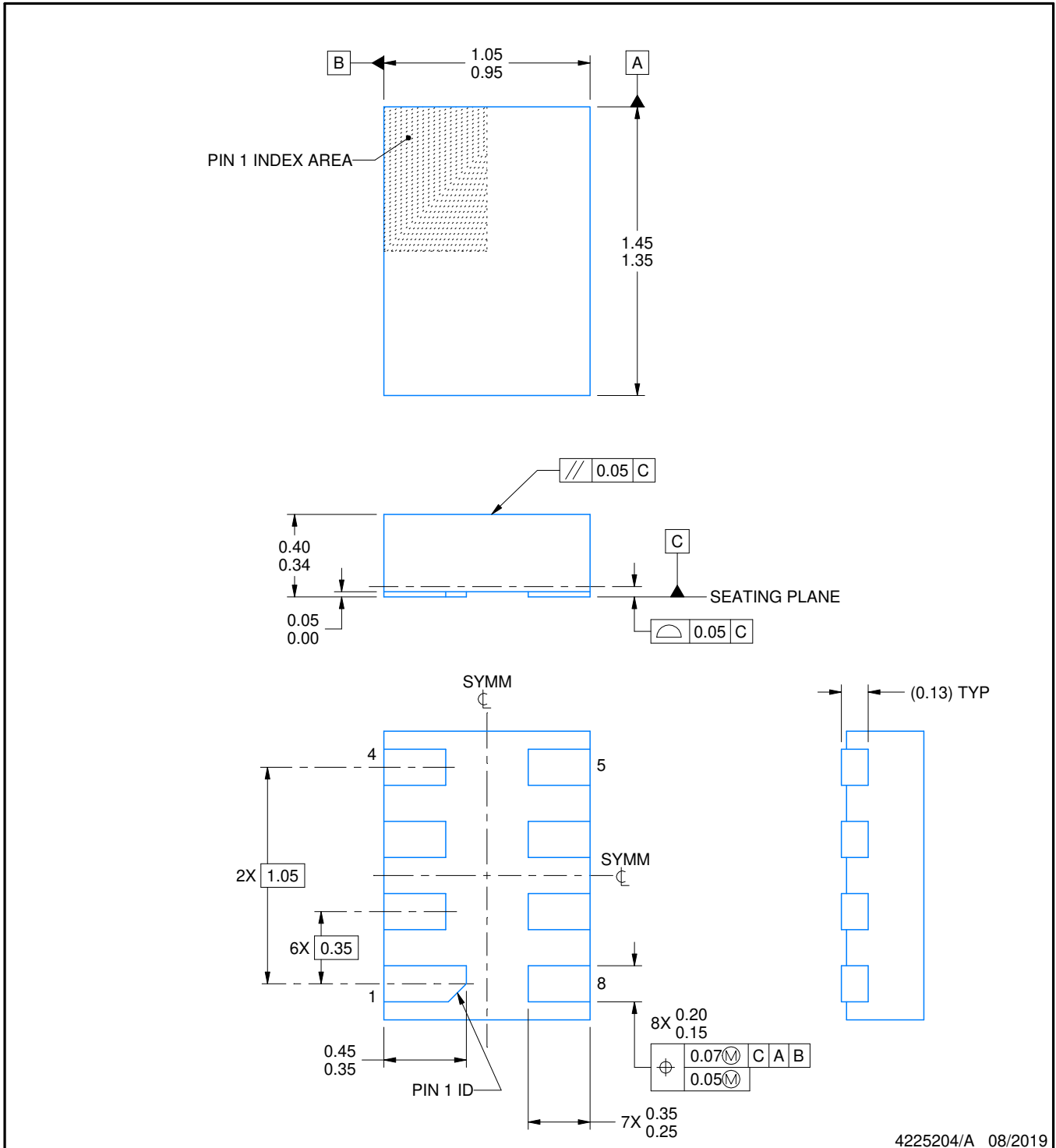
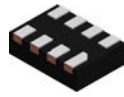

4225204/A 08/2019

NOTES:

1. All linear dimensions are in millimeters. Any dimensions in parenthesis are for reference only. Dimensioning and tolerancing per ASME Y14.5M.
2. This drawing is subject to change without notice.
3. This package complies to JEDEC MO-287 variation X2EAF.

EXAMPLE BOARD LAYOUT

DQE0008A

X2SON - 0.4 mm max height

PLASTIC SMALL OUTLINE - NO LEAD

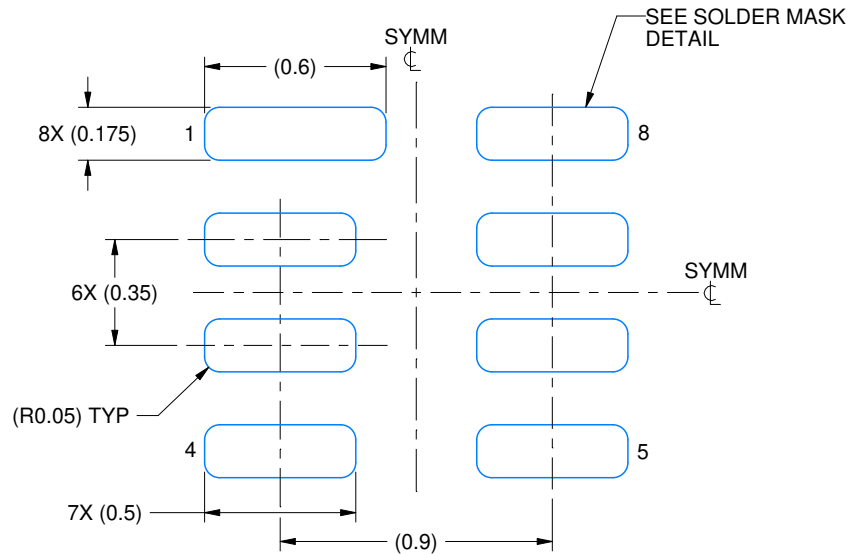

LAND PATTERN EXAMPLE
EXPOSED METAL SHOWN
SCALE: 40X

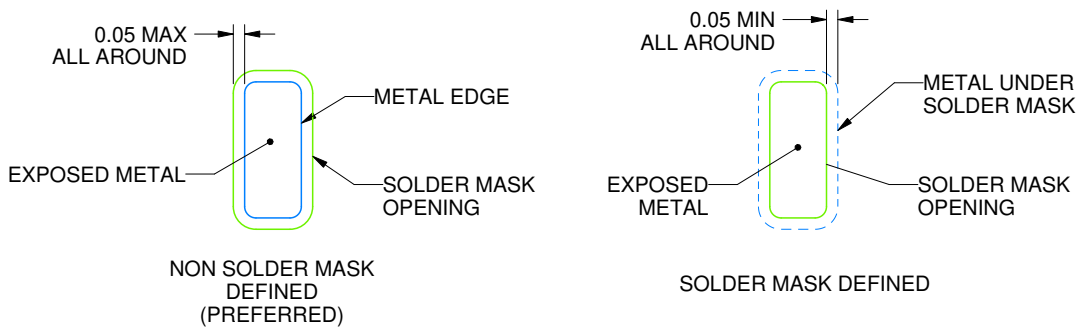

SOLDER MASK DETAILS

4225204/A 08/2019

NOTES: (continued)

- This package is designed to be soldered to a thermal pad on the board. For more information, see Texas Instruments literature number SLUA271 (www.ti.com/lit/slua271).

EXAMPLE STENCIL DESIGN

DQE0008A

X2SON - 0.4 mm max height

PLASTIC SMALL OUTLINE - NO LEAD

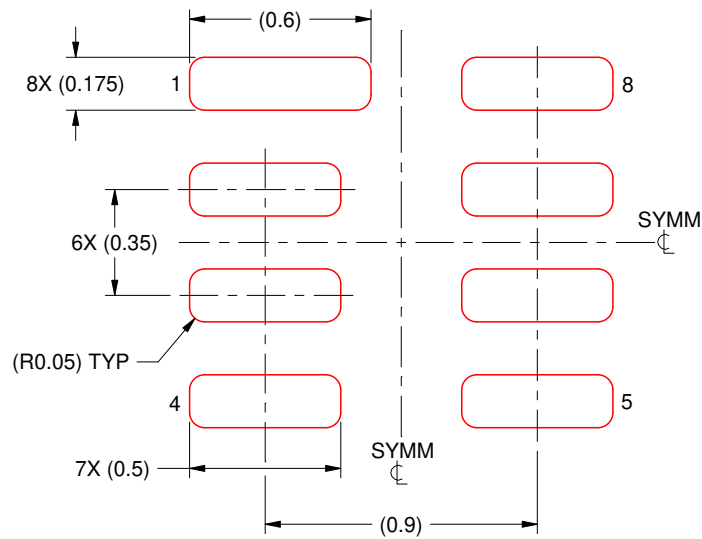

SOLDER PASTE EXAMPLE
BASED ON 0.075 MM THICK STENCIL
SCALE: 40X

4225204/A 08/2019

NOTES: (continued)

5. Laser cutting apertures with trapezoidal walls and rounded corners may offer better paste release. IPC-7525 may have alternate design recommendations.

YFP0008

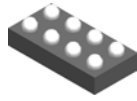

PACKAGE OUTLINE

DSBGA - 0.5 mm max height

DIE SIZE BALL GRID ARRAY

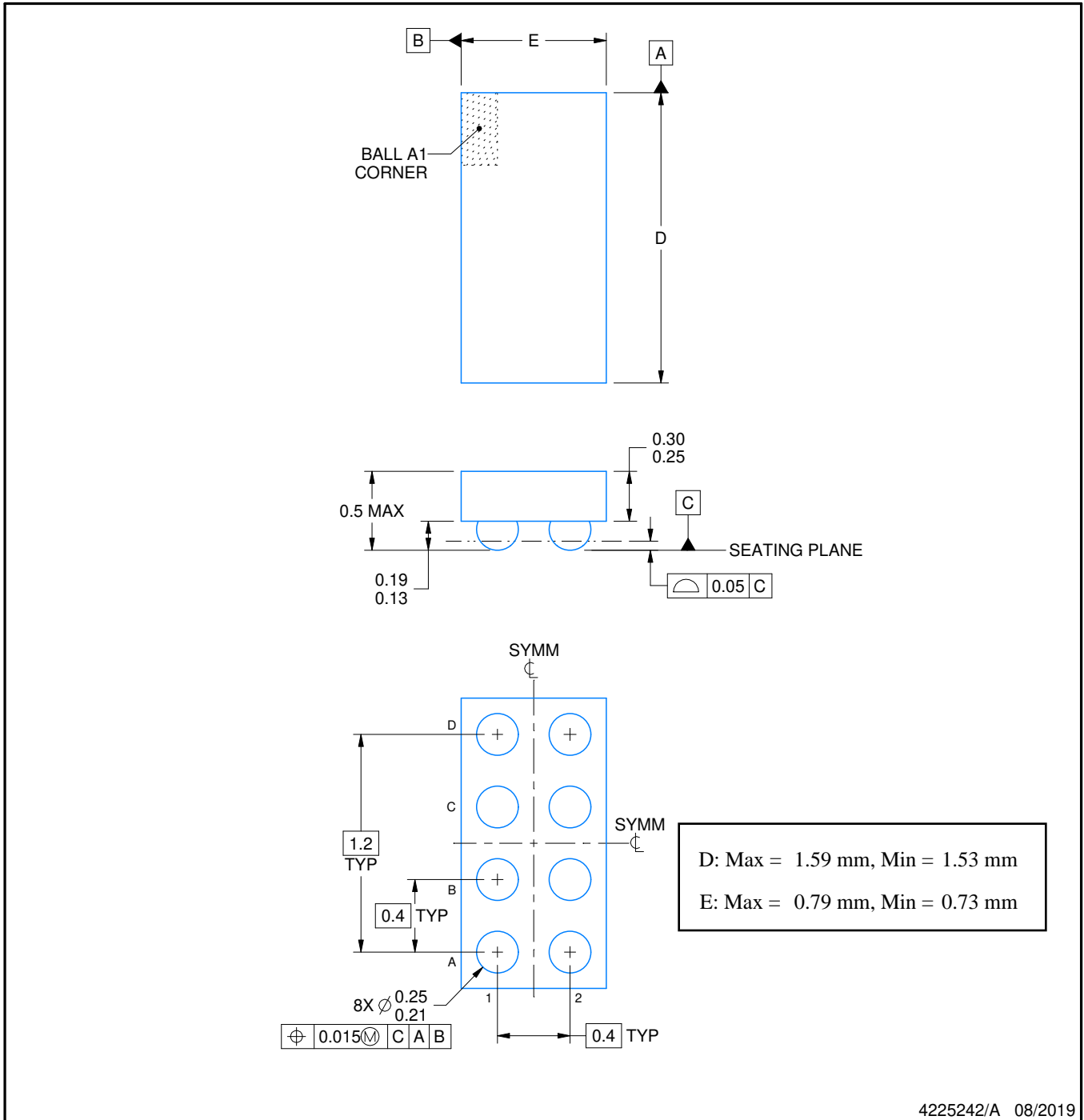

NOTES:

1. All linear dimensions are in millimeters. Any dimensions in parenthesis are for reference only. Dimensioning and tolerancing per ASME Y14.5M.
2. This drawing is subject to change without notice.

EXAMPLE BOARD LAYOUT

YFP0008

DSBGA - 0.5 mm max height

DIE SIZE BALL GRID ARRAY

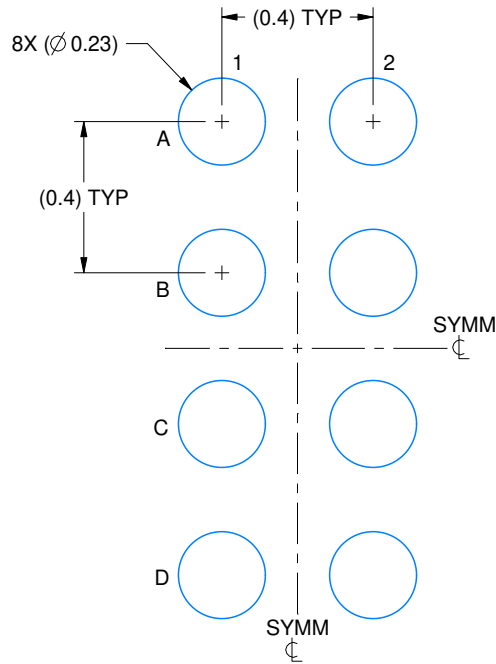

LAND PATTERN EXAMPLE
EXPOSED METAL SHOWN
SCALE: 50X

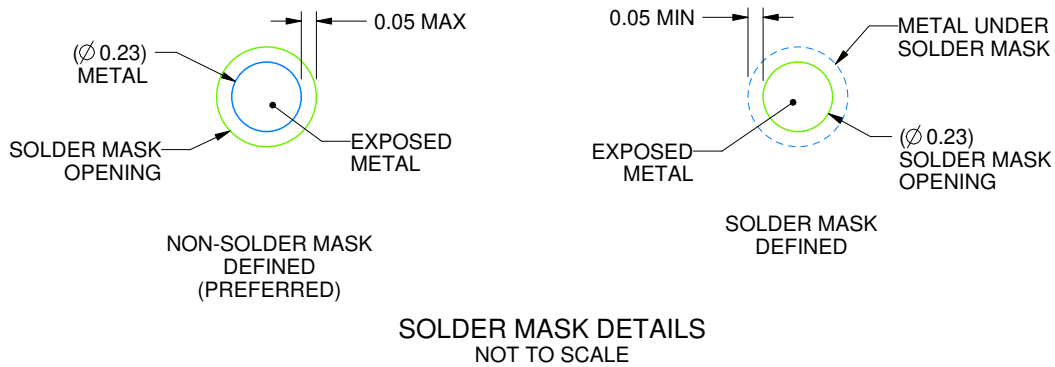

SOLDER MASK DETAILS
NOT TO SCALE

4225242/A 08/2019

NOTES: (continued)

- Final dimensions may vary due to manufacturing tolerance considerations and also routing constraints. See Texas Instruments Literature No. SNVA009 (www.ti.com/lit/snva009).

EXAMPLE STENCIL DESIGN

YFP0008

DSBGA - 0.5 mm max height

DIE SIZE BALL GRID ARRAY

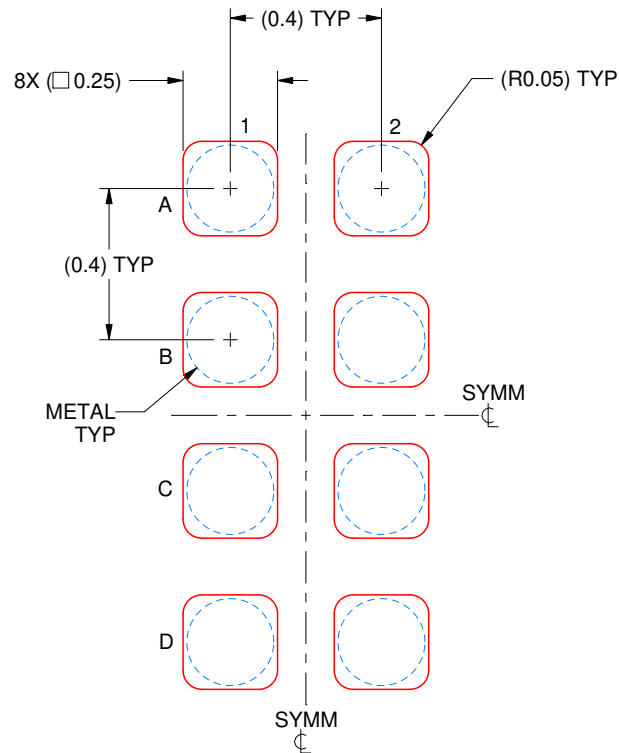

SOLDER PASTE EXAMPLE
BASED ON 0.1 mm THICK STENCIL
SCALE: 50X

4225242/A 08/2019

NOTES: (continued)

4. Laser cutting apertures with trapezoidal walls and rounded corners may offer better paste release.

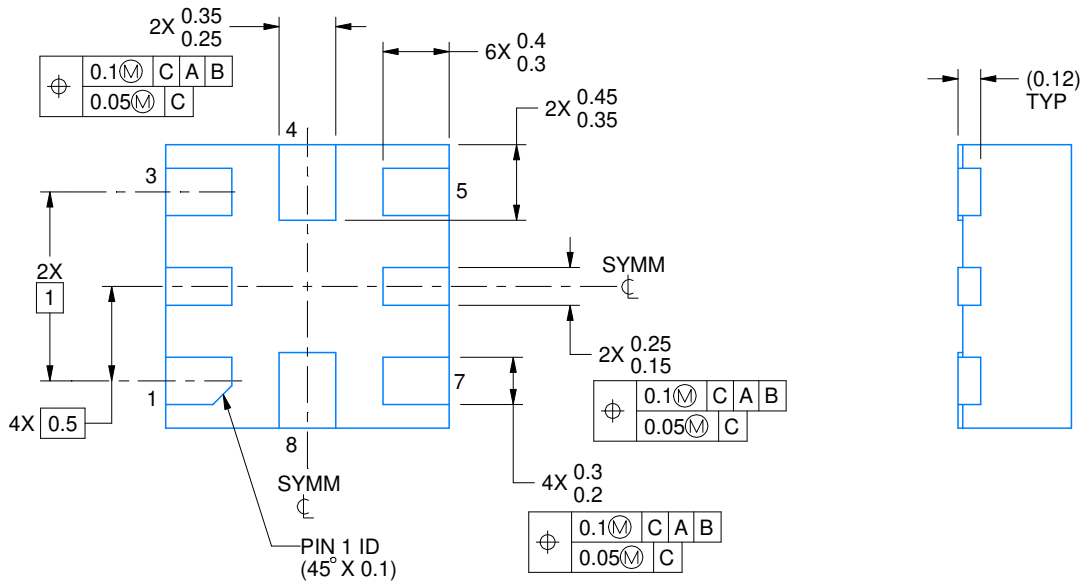
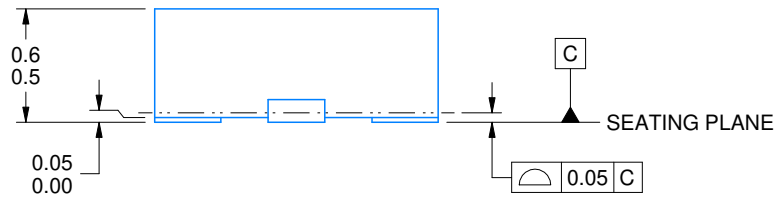
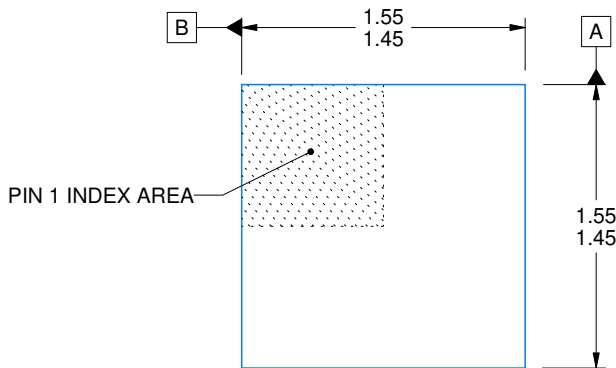

4220323/B 03/2018

NOTES:

1. All linear dimensions are in millimeters. Any dimensions in parenthesis are for reference only. Dimensioning and tolerancing per ASME Y14.5M.
2. This drawing is subject to change without notice.

EXAMPLE BOARD LAYOUT

RSE0008A

UQFN - 0.6 mm max height

PLASTIC QUAD FLATPACK - NO LEAD

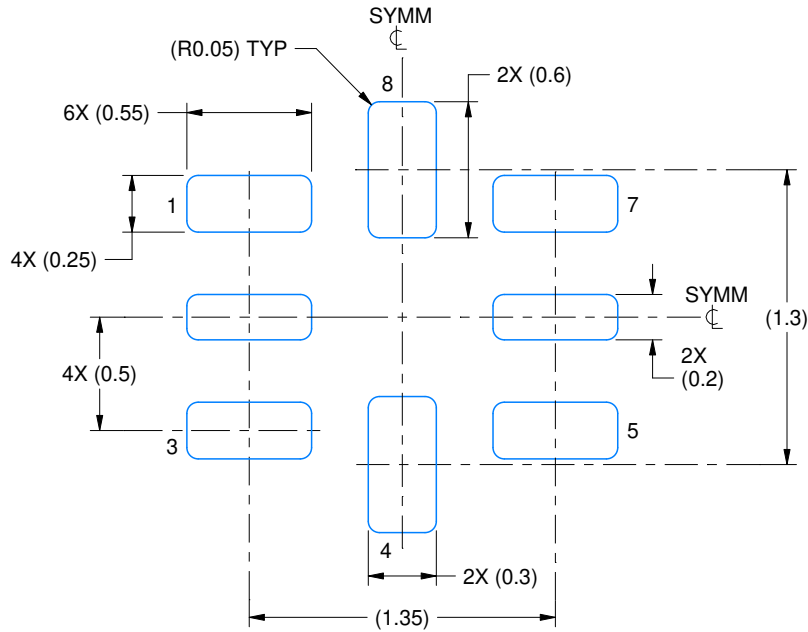

LAND PATTERN EXAMPLE
SCALE:30X

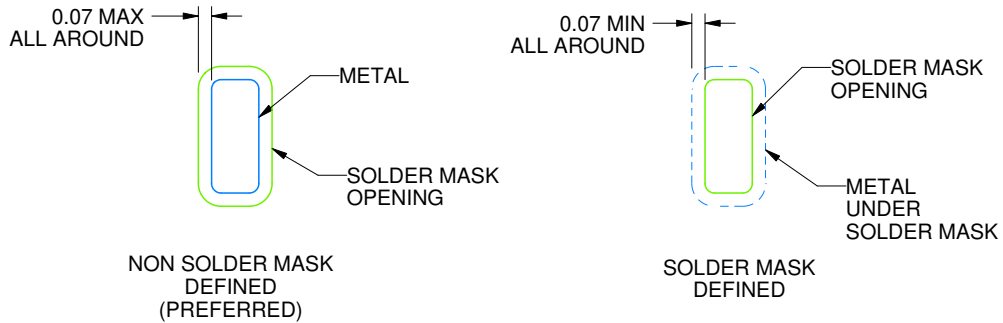

SOLDER MASK DETAILS
NOT TO SCALE

4220323/B 03/2018

NOTES: (continued)

3. For more information, see Texas Instruments literature number SLUA271 (www.ti.com/lit/slua271).

EXAMPLE STENCIL DESIGN

RSE0008A

UQFN - 0.6 mm max height

PLASTIC QUAD FLATPACK - NO LEAD

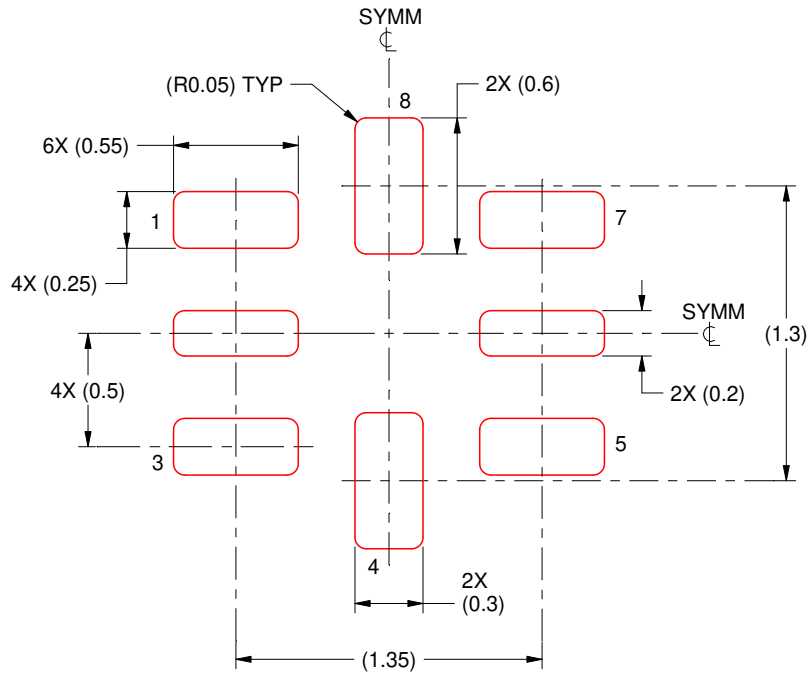

SOLDER PASTE EXAMPLE
BASED ON 0.1 mm THICKNESS
SCALE: 30X

4220323/B 03/2018

NOTES: (continued)

5. Laser cutting apertures with trapezoidal walls and rounded corners may offer better paste release. IPC-7525 may have alternate design recommendations.

YZP0008



PACKAGE OUTLINE

DSBGA - 0.5 mm max height

DIE SIZE BALL GRID ARRAY

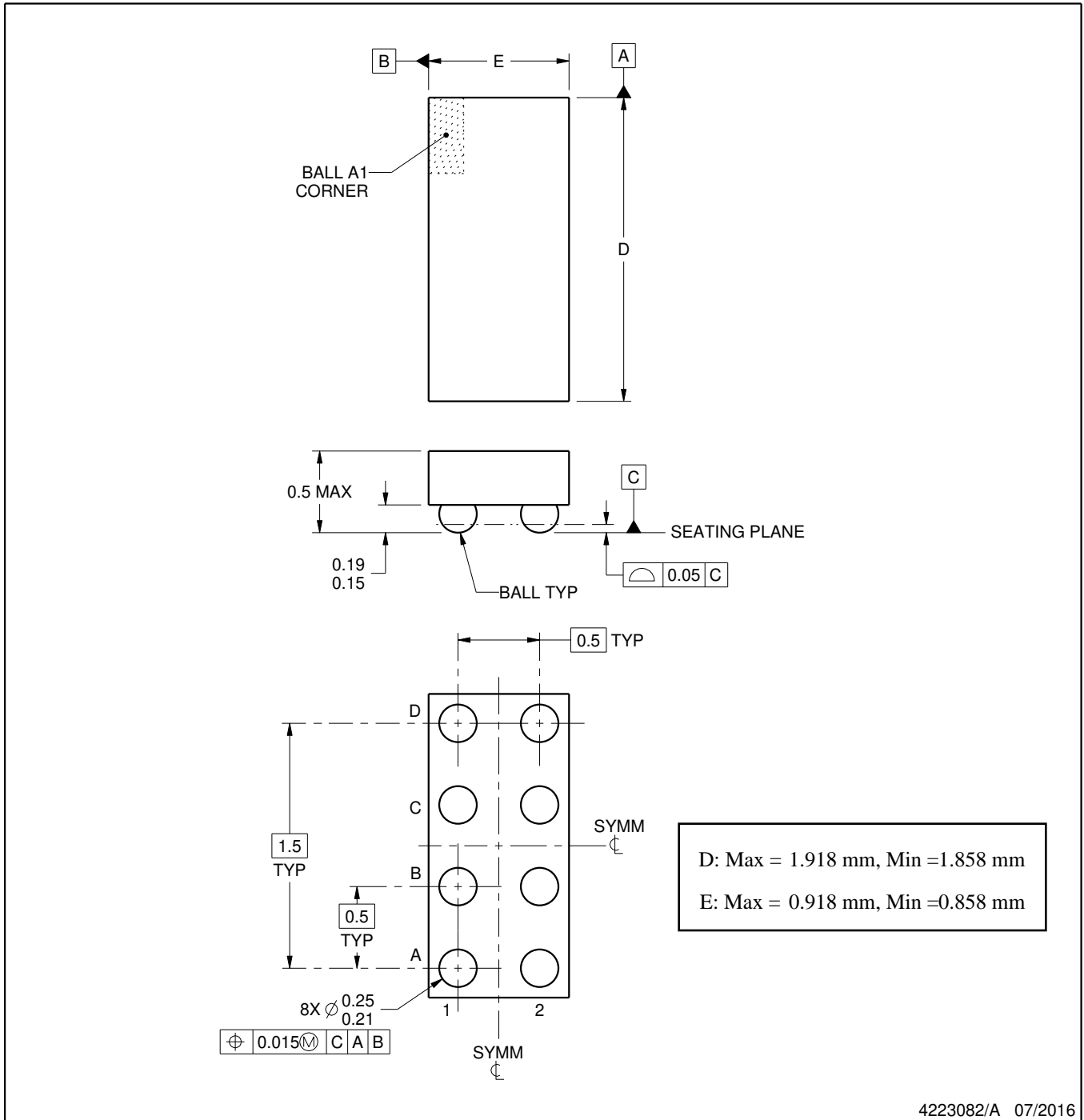

NOTES:

1. All linear dimensions are in millimeters. Any dimensions in parenthesis are for reference only. Dimensioning and tolerancing per ASME Y14.5M.
2. This drawing is subject to change without notice.

EXAMPLE BOARD LAYOUT

YZP0008

DSBGA - 0.5 mm max height

DIE SIZE BALL GRID ARRAY

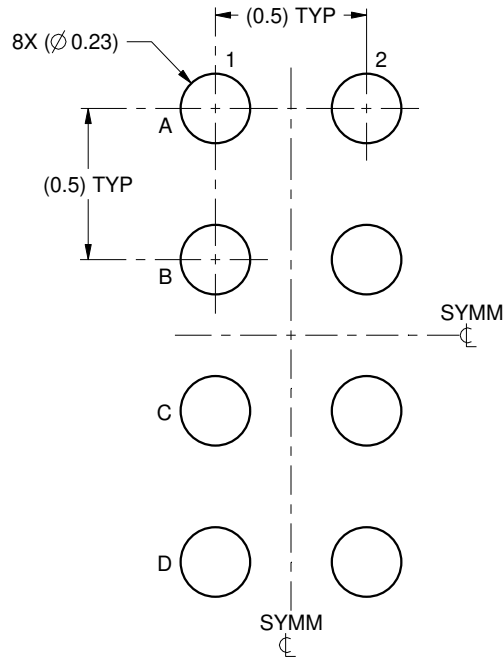

LAND PATTERN EXAMPLE
SCALE:40X

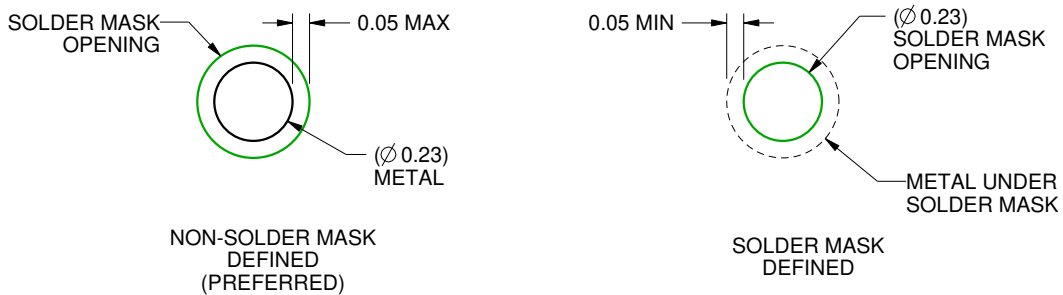

SOLDER MASK DETAILS
NOT TO SCALE

4223082/A 07/2016

NOTES: (continued)

3. Final dimensions may vary due to manufacturing tolerance considerations and also routing constraints. For more information, see Texas Instruments literature number SNVA009 (www.ti.com/lit/snva009).

EXAMPLE STENCIL DESIGN

YZP0008

DSBGA - 0.5 mm max height

DIE SIZE BALL GRID ARRAY

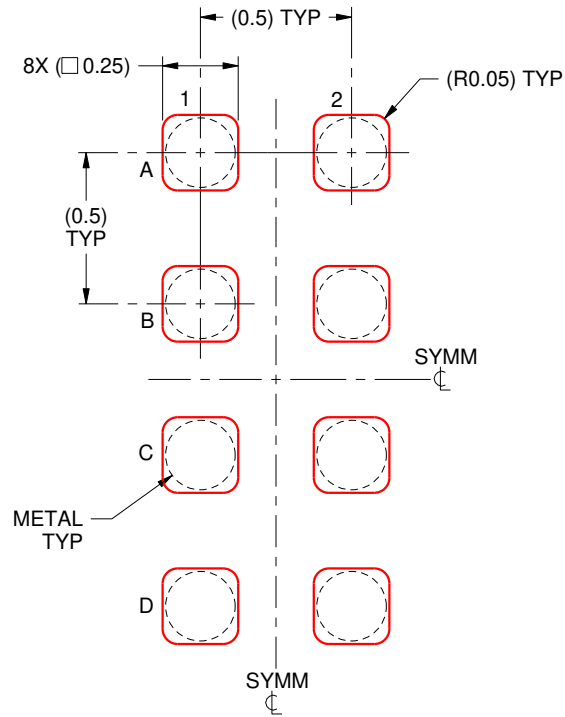

SOLDER PASTE EXAMPLE
BASED ON 0.1 mm THICK STENCIL
SCALE:40X

4223082/A 07/2016

NOTES: (continued)

4. Laser cutting apertures with trapezoidal walls and rounded corners may offer better paste release.

EXAMPLE BOARD LAYOUT

DCU0008A

VSSOP - 0.9 mm max height

SMALL OUTLINE PACKAGE

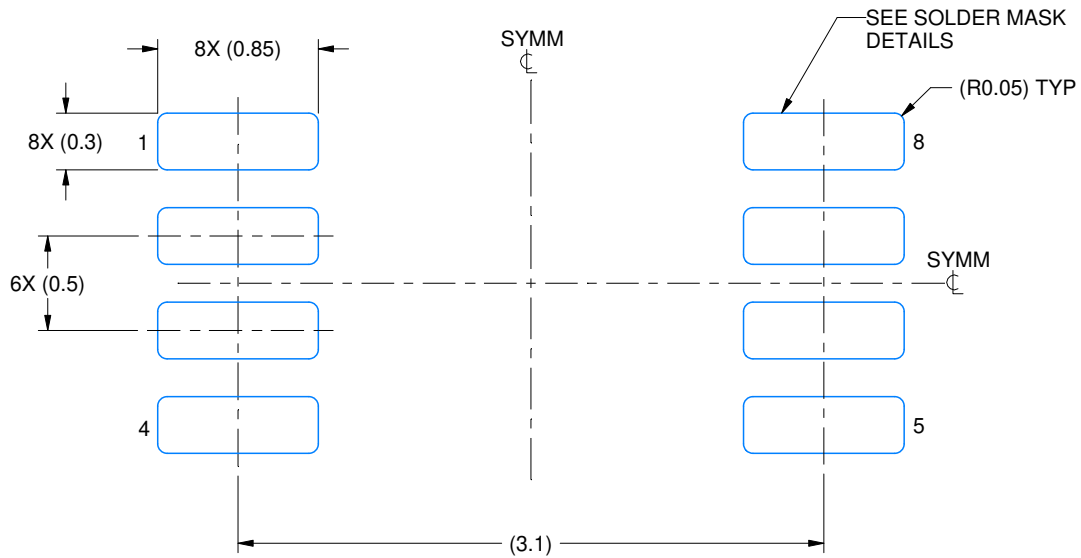

LAND PATTERN EXAMPLE
EXPOSED METAL SHOWN
SCALE: 25X

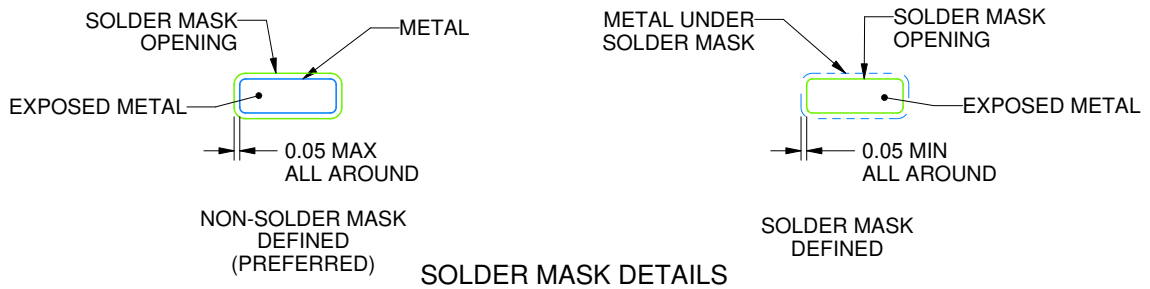

4225266/A 09/2014

NOTES: (continued)

- 5. Publication IPC-7351 may have alternate designs.
- 6. Solder mask tolerances between and around signal pads can vary based on board fabrication site.

EXAMPLE STENCIL DESIGN

DCU0008A

VSSOP - 0.9 mm max height

SMALL OUTLINE PACKAGE

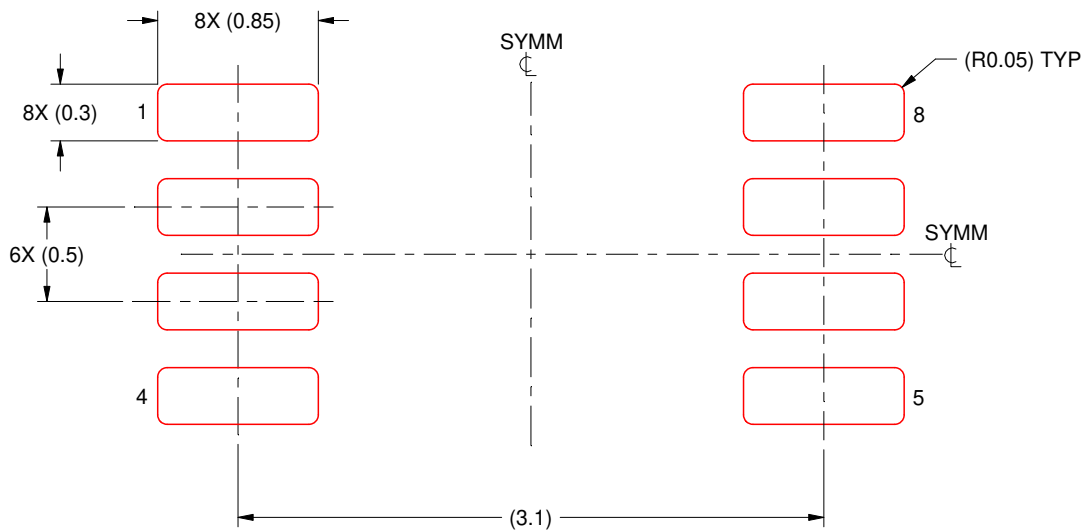

SOLDER PASTE EXAMPLE
BASED ON 0.125 mm THICK STENCIL
SCALE: 25X

4225266/A 09/2014

NOTES: (continued)

7. Laser cutting apertures with trapezoidal walls and rounded corners may offer better paste release. IPC-7525 may have alternate design recommendations.
8. Board assembly site may have different recommendations for stencil design.

IMPORTANT NOTICE AND DISCLAIMER

TI PROVIDES TECHNICAL AND RELIABILITY DATA (INCLUDING DATA SHEETS), DESIGN RESOURCES (INCLUDING REFERENCE DESIGNS), APPLICATION OR OTHER DESIGN ADVICE, WEB TOOLS, SAFETY INFORMATION, AND OTHER RESOURCES "AS IS" AND WITH ALL FAULTS, AND DISCLAIMS ALL WARRANTIES, EXPRESS AND IMPLIED, INCLUDING WITHOUT LIMITATION ANY IMPLIED WARRANTIES OF MERCHANTABILITY, FITNESS FOR A PARTICULAR PURPOSE OR NON-INFRINGEMENT OF THIRD PARTY INTELLECTUAL PROPERTY RIGHTS.

These resources are intended for skilled developers designing with TI products. You are solely responsible for (1) selecting the appropriate TI products for your application, (2) designing, validating and testing your application, and (3) ensuring your application meets applicable standards, and any other safety, security, regulatory or other requirements.

These resources are subject to change without notice. TI grants you permission to use these resources only for development of an application that uses the TI products described in the resource. Other reproduction and display of these resources is prohibited. No license is granted to any other TI intellectual property right or to any third party intellectual property right. TI disclaims responsibility for, and you will fully indemnify TI and its representatives against, any claims, damages, costs, losses, and liabilities arising out of your use of these resources.

TI's products are provided subject to [TI's Terms of Sale](#) or other applicable terms available either on [ti.com](https://www.ti.com) or provided in conjunction with such TI products. TI's provision of these resources does not expand or otherwise alter TI's applicable warranties or warranty disclaimers for TI products.

TI objects to and rejects any additional or different terms you may have proposed.

Mailing Address: Texas Instruments, Post Office Box 655303, Dallas, Texas 75265
Copyright © 2023, Texas Instruments Incorporated