

REVISIONS					
P	LTR	DESCRIPTION	DATE	DWN	APVD
	H2	NEW DRAWING PER ECO-11-019045	02APR12	KH	DR
	H3	REVISED PER ECO-17-007400	29NOV2017	RS	DR

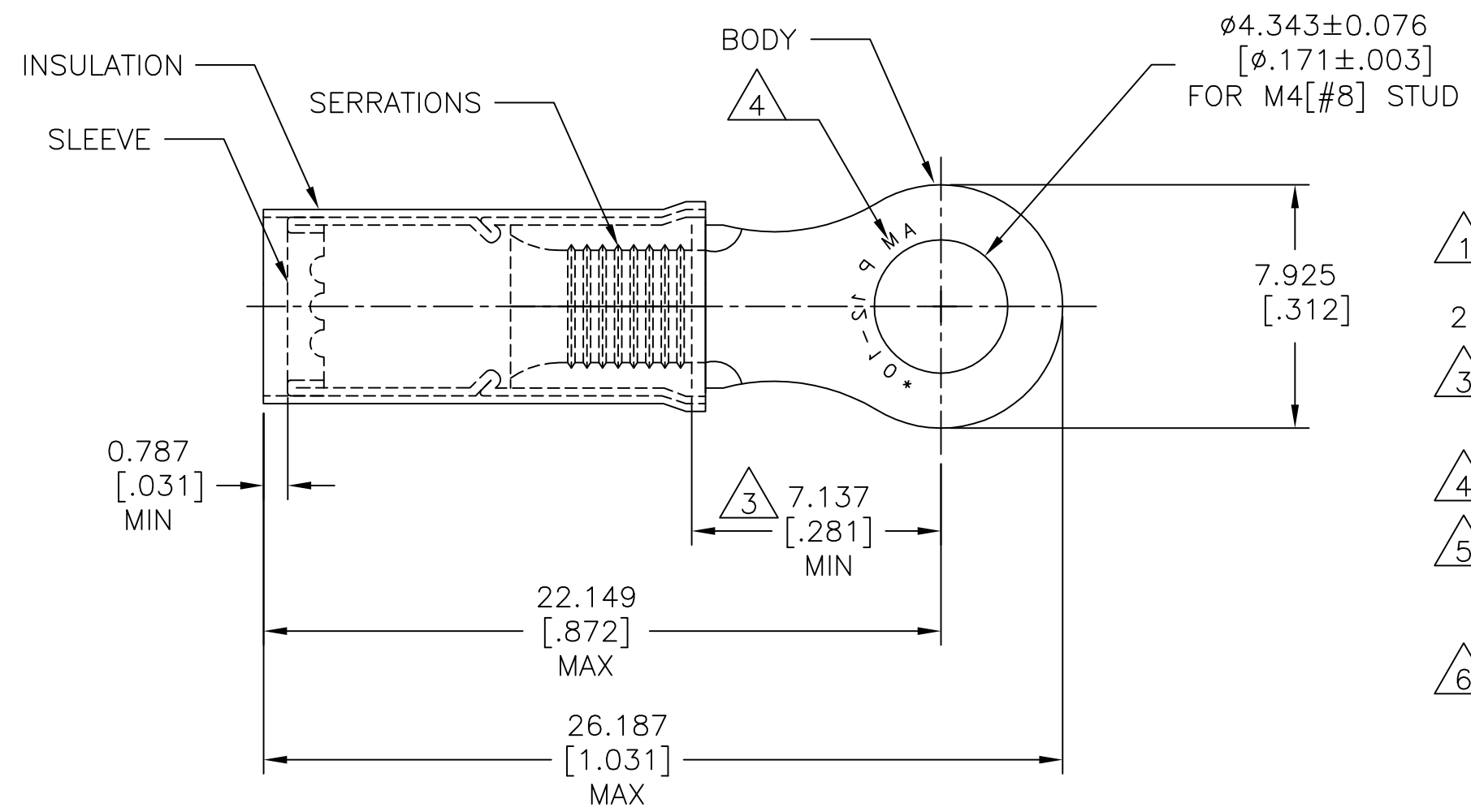

AMP WIRE RANGE	Listed FILE E13288	LR7189 Certified
12-10 AWG SOLID OR STRANDED	12-10 AWG SOLID OR STRANDED	12-10 AWG SOLID OR STRANDED

- 1 FOR WIRE INSULATION: $\phi 3.810[\phi.150]$ TO $\phi 5.842[\phi.230]$
- 2 BODY MATERIAL THK: $1.016 \pm 0.051[.040 \pm .002]$
- 3 APPLIES FROM EDGE OF METAL WIRE BARREL TO CENTER OF STUD HOLE.
- 4 STAMP AMP 12-10* APPROX AS SHOWN
- 5 MATERIAL:
BODY&SLEEVE: COPPER PER ASTM B152
INSULATION: NYLON.
- 6 FINISH:
BODY&SLEEVE: TIN PLATE PER ASTM B545
INSULATION: COLOR-YELLOW

2500	ON TAPE REEL	1-35787-0
500	LOOSE PIECE	35787
QTY	PACKAGE TYPE	PART NO

AMP INCORPORATED
 CUSTOMER SERVICE SYSTEMS

FOR ADDITIONAL PRODUCT INFORMATION OR COPIES OF DRAWINGS AND TECHNICAL DOCUMENTS	PRODUCT INFORMATION CENTER 1-800-522-6752	RECOMMENDED OPERATING TEMPERATURE: 105°C [221°F]
FOR APPLICATION TOOLING INFORMATION	TOOLING ASSISTANCE CENTER 1-800-722-1111	VOLTAGE RATING: 300V MAX
FOR ORDER ENTRY	1-800-526-5142	WIRE CROSS SECTIONAL AREA RANGE: 2.62-6.64mm ² [5,180-13,100] SOLID OR STRANDED

THIS DRAWING IS A CONTROLLED DOCUMENT.	
DIMENSIONS: mm [INCHES]	TOLERANCES UNLESS OTHERWISE SPECIFIED:
	0 PLC ± -
	1 PLC ± -
	2 PLC ± -
	3 PLC ± 0.127[.005]
	4 PLC ± -
	ANGLES ± 5°
MATERIAL	FINISH

DWN KIRAN HOLAL 02APR12	TE Connectivity
CHK ROHDE DANIEL 02APR12	
APVD ROHDE DANIEL 02APR12	
NAME ROHDE DANIEL	
PRODUCT SPEC UL 486 A-B	WIRE TERMINAL P.I.D.G RING TONGUE WIRE SIZE: 12-10
APPLICATION SPEC 114-2157	SIZE A3
WEIGHT -	CAGE CODE 00779
CUSTOMER DRAWING	DRAWING NO C=35787
SCALE 5:1	SHEET 1 OF 1
REV H3	RESTRICTED TO -