

REVISIONS					
REV	ECO	DESCRIPTION	DATE	BY	APPR
A1	--	RELEASE NEW PRODUCT	04/SEP/19	JOE	TOMMY

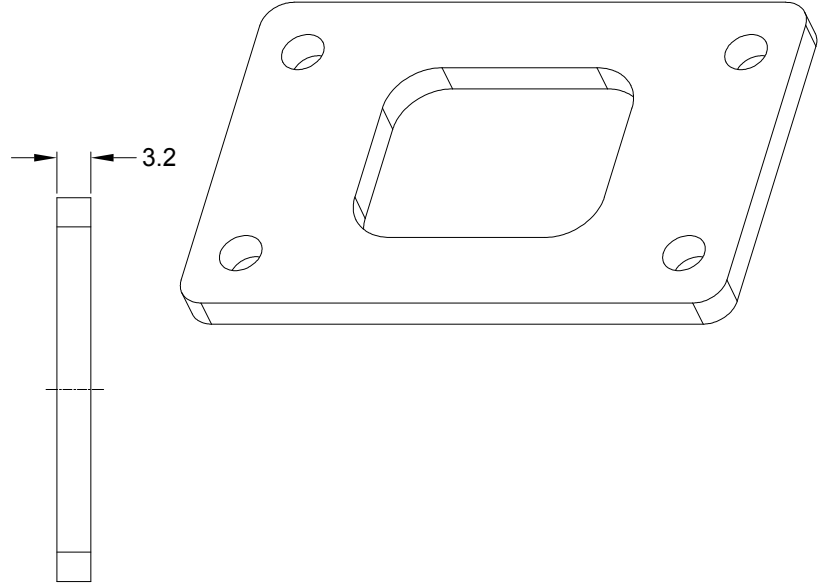
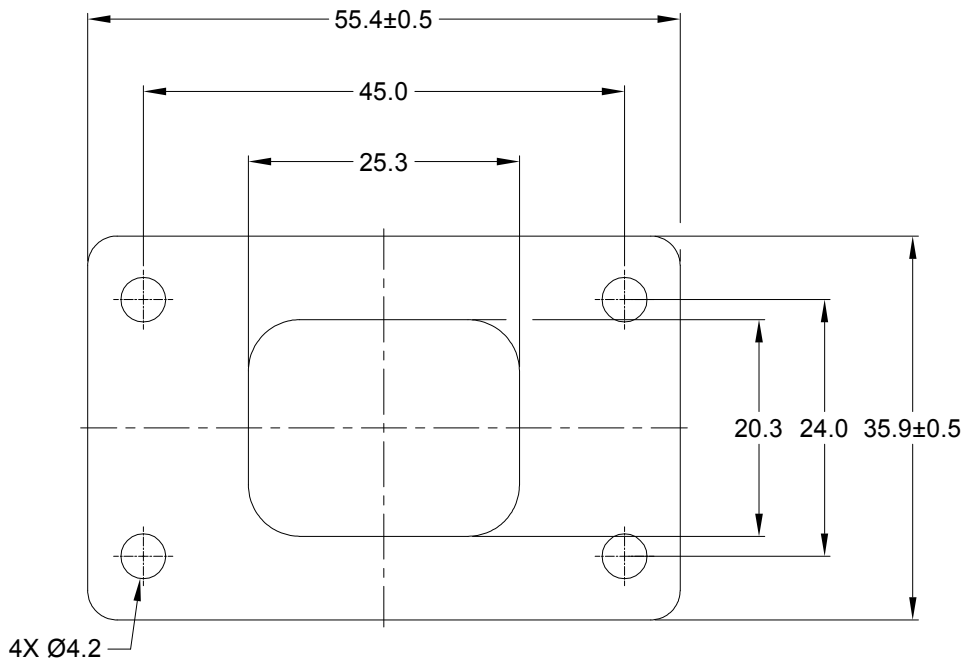

NOTES: UNLESS OTHERWISE SPECIFIED

1. MATERIAL: CLD CELL SPONGE
2. COLORS: BLACK
3. RoHS COMPLIANT
4. USE WITH AT04-08P*-L012/LE11/CLXX (*=A,B,C,D KEYS, XX=ALL MODIFICATIONS)
5. ALL DIMENSIONS ARE FOR REFERENCE USE ONLY.

AT8P-L012-GKT		REF:DT8P-L012-GKT	
PART NUMBER		DESCRIPTION	
QUANTITY	MATERIALS LIST		
<p>UNLESS OTHERWISE SPECIFIED</p> <p>1) All dimensions are in metric(mm).</p> <p>2) Tolerances are as follows:</p> <p>1 PL DEC ±0.30 Fractions ±1/64</p> <p>2 PL DEC ±0.15 Angles ±1°</p> <p>3 PL DEC ±0.08</p> <p>3) Note reference = </p>		<p>SIGNATURES</p> <p>DRAWN: JOE.SONG 04/SEP/19</p> <p>CHECKED: ORION.LI 04/SEP/19</p> <p>ENGINEER:</p> <p>APPROVAL: TOMMY.XIE 04/SEP/19</p> <p>CUSTOMER:</p>	
MATERIAL SPECIFICATIONS:		<p>Amphenol</p> <p>Sine Systems - www.amphenol-sine.com 44724 Morley Drive Clinton Township, MI 48036</p>	
PROCESS SPECIFICATIONS:		<p>GASKET,RECEPTACLE,8 PIN,AT SERIES</p>	
NEXT ASSY:		<p>THIS DRAWING IS SUPPLIED FOR INFORMATION ONLY. DESIGN FEATURES, SPECIFICATIONS AND PERFORMANCE DATA SHOWN HEREON ARE THE PROPERTY OF THE AMPHENOL CORPORATION. NO RIGHTS OF REPRODUCTION ARE IMPLIED. ALL DIMENSIONS ARE SUBJECT TO NORMAL MANUFACTURING VARIATIONS.</p>	
		<p>SIZE: A TYPE: C-</p> <p>SCALE: NONE</p>	<p>DWG NO: AT8P-L012-GKT</p> <p>REVISION: A1</p> <p>SHEET 1 OF 1</p>