

THIS DRAWING IS UNPUBLISHED. RELEASED FOR PUBLICATION
 © COPYRIGHT BY TYCO ELECTRONICS CORPORATION. ALL RIGHTS RESERVED.

LOC		DIST		REVISIONS			
P	LTR	DESCRIPTION	DATE	DWN	APVD		
AD	00	A1	ECO-06-029077	06FEB2007	RB	MS	

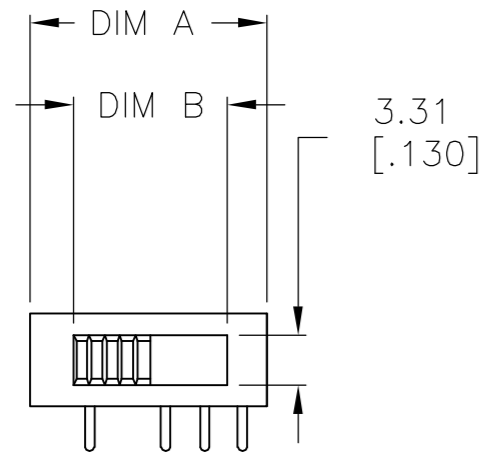

SPECIFICATIONS:
 MAKE-BEFORE-BREAK

MATERIALS:
 FRAME: STEEL, ZINC PLATE
 ACTUATOR: POM UL94HB, BLACK
 FIXED CONTACT/TERMINAL: COPPER ALLOY, SILVER OVER NICKEL PLATE
 MOVING CONTACT: COPPER ALLOY, SILVER CLAD
 COIL SPRING: TEMPERED STEEL WIRE
 BALL- TEMPERED CARBON STEEL
 TERMINAL BOARD: PHENOLIC, UL94HB
 TERMINAL SEAL: EPOXY

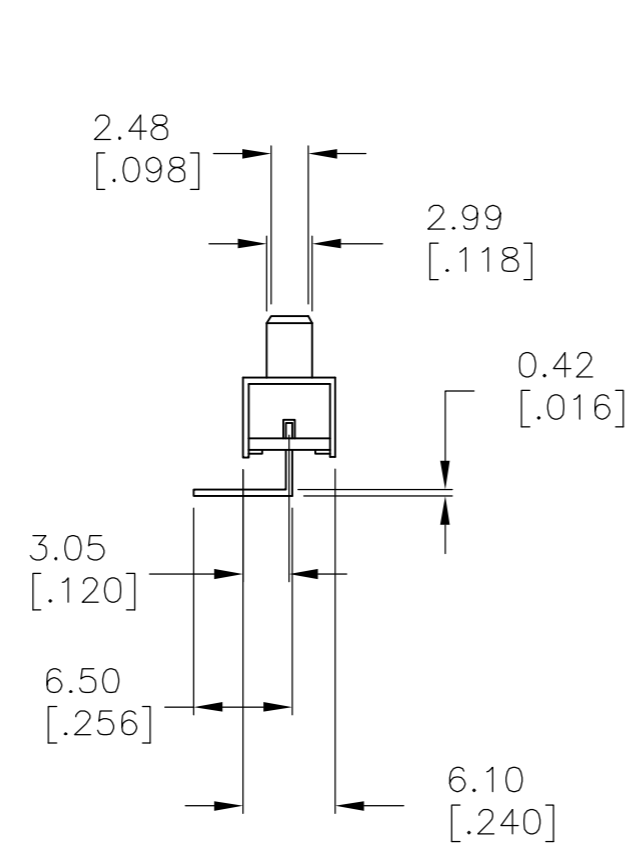
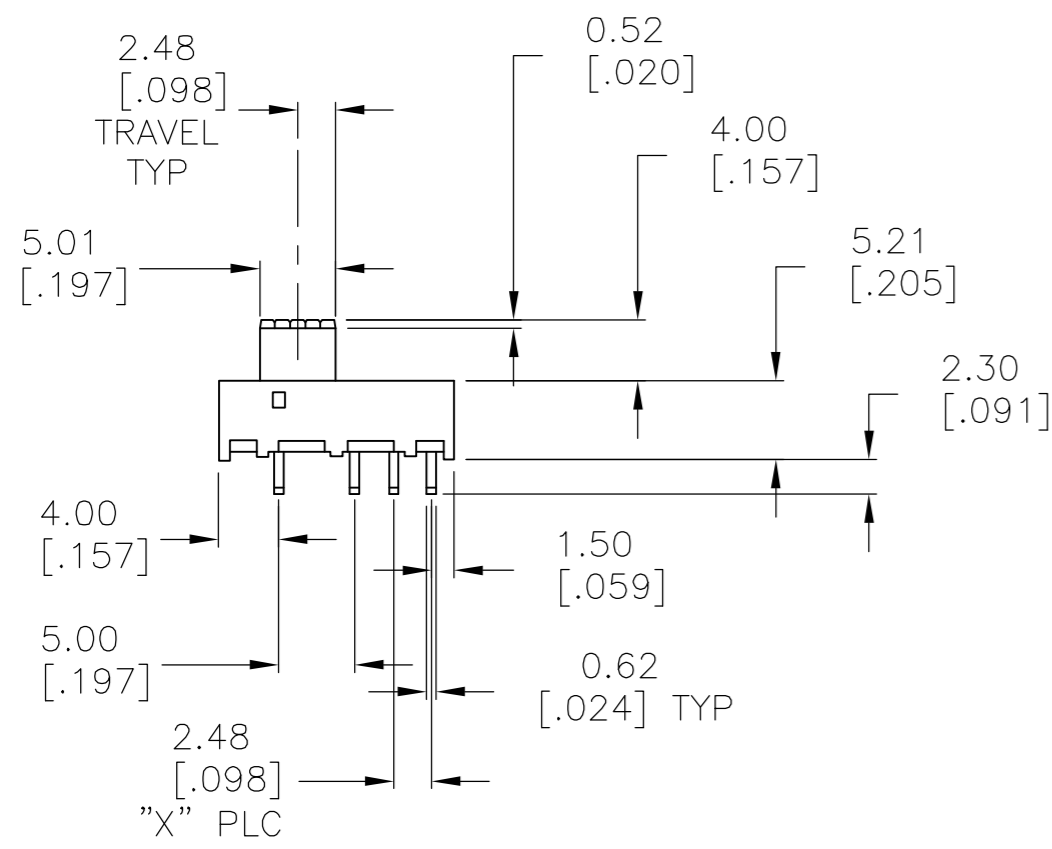

ELECTRICAL:
 CONTACT RATING: 250 MILLIAMPS@125V AC
 CONTACT RESISTANCE: 30 MILLIOHMS MAX (INITIAL), 60 MILLIOHMS AFTER TEST
 INSULATION RESISTANCE: 500 MEGOHMS MIN AT 500V DC
 DIELECTRIC STRENGTH: 500 VAC RMS AT SEA LEVEL
 LIFE EXPECTANCY: 10,000 CYCLES MIN. NO LOAD

MECHANICAL:
 ACTUATION FORCE: 250 +150/-100 GRAMS
 TRAVEL: 2.49 (.098)

ENVIRONMENTAL:
 OPERATING TEMPERATURE: -10° TO +60°C
 STORAGE TEMPERATURE: -10° TO +60°C
 RESISTANCE TO SOLDER HEAT: 260°C FOR 10 SEC PER 109-202, COND. B
 SOLDERABILITY: PER EIA-364-56A, PROCEDURE 3, COND. B

- NOTES:
- ALL MATERIALS AND FINISHES SHALL COMPLY WITH EU DIRECTIVE 2002/95/EC OF 27JAN2003 (ROHS)
 - ALL PERFORMANCE SPECIFICATIONS WERE TESTED IN ACCORDANCE WITH JIS-C-5441 UNLESS OTHERWISE STATED.

1825162-1 AS SHOWN

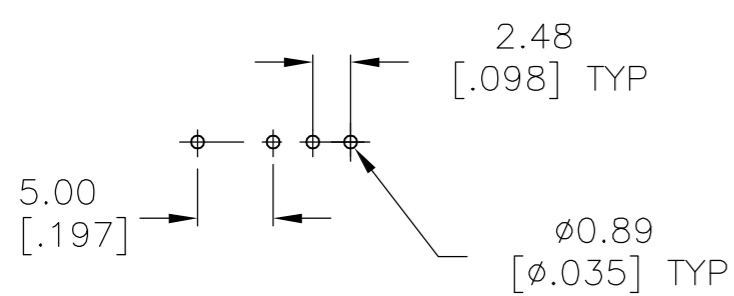
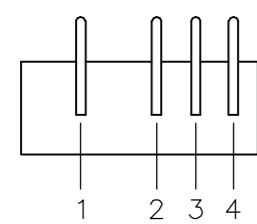

P.C. HOLE LAYOUT (1825162-1)

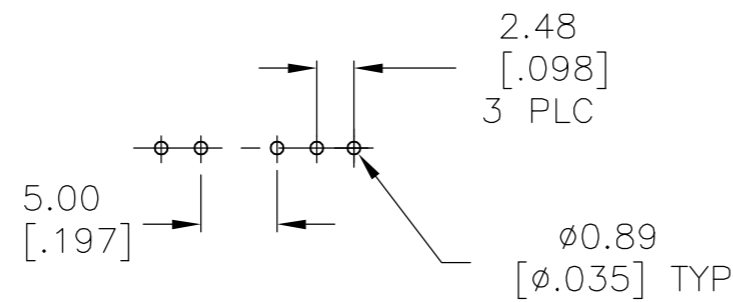

P.C. HOLE LAYOUT (1825162-2)

1-3	2-3	3-4	3-5	-	-	-	1 2 3 4 5	3	12.50[.492]	18.01[.709]	SP4T	STS1400RA04	1825162-2	
-	-	-	-	1-2	2-3	2-4	1 2 3 4	2	10.01[.394]	15.50[.610]	SP3T	STS1300RA04	1825162-1	
FUNCTION DIAGRAM								BOTTOM VIEW	X PLC	DIM B	DIM A	FUNCTION	T&B P/N	TYCO P/N

THIS DRAWING IS A CONTROLLED DOCUMENT.

DIMENSIONS: mm [INCHES]	TOLERANCES UNLESS OTHERWISE SPECIFIED:	DWN: B.S.VISWESWARA	01APR05	Tyco Electronics Corporation Harrisburg, Pa 17105-3608	
	0 PLC ± -	CHK: M S SARVER	APVD: -		NAME: SLIDE SWITCH, STS1300RA & STS1400RA SERIES
	1 PLC ± -	PRODUCT SPEC: -	APVD: -		SIZE: A2
	2 PLC ± 0.20[.008]	APPLICATION SPEC: -	APVD: -		CAGE CODE: 00779
MATERIAL: -	FINISH: -	WEIGHT: -	SCALE: 2:1	DRAWING NO: C=1825162	
CUSTOMER DRAWING				RESTRICTED TO: -	
				SHEET 1 OF 1	
				REV A1	

1825162

A