

QT-Brightek PLCC Series**3228 (3528) PLCC6 RGB LED****Part No.: QBLP680-RGB1****RGB1: Black Face, White Diffused Lens**



Table of Contents

Introduction	3
Electrical / Optical Characteristic (Ta=25 °C)	4
Absolute Maximum Rating	4
Characteristic Curves	6
Solder Profile & Footprint	7
Packing	8
Ordering Information	9
Revision History	10
Disclaimer	10

Introduction

Feature:

- Black Face
- White diffused lens
- Ultra bright 3228 (3528) PLCC6 RGB LED
- InGaN technology for IB/IG
- AlInGaP technology for R
- Viewing angle: 120 deg typ.

Description:

This compact 3228 (3528) PLCC6 mini RGB LEDs have a height profile of 1.80mm. Combination of high brightness output and robust package, this LED is ideal for large signs and outdoor display

Application:

- Status indication
- Back lighting application

Certification & Compliance:

- TS16949
- ISO 9001
- RoHS Compliant



Dimension:

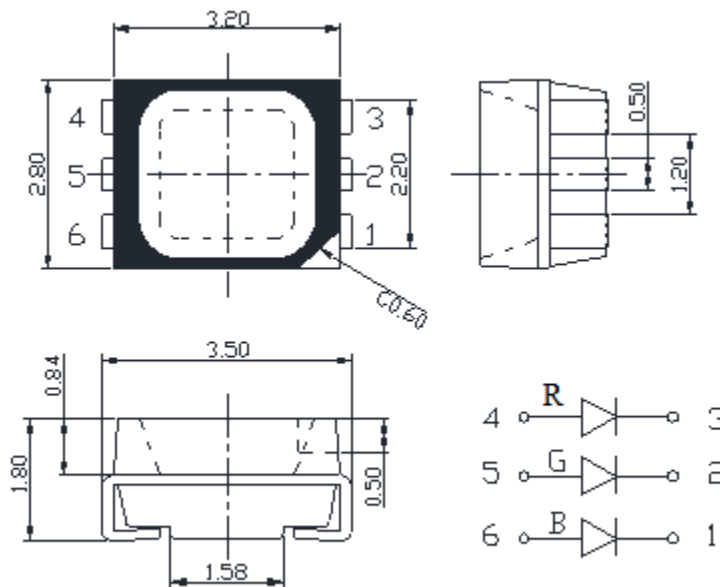

Units: mm / tolerance = +/-0.2mm

Electrical / Optical Characteristic (Ta=25 °C)

Product	Color	I _F (mA)	V _F (V)		λ _D (nm)			I _V (mcd)		
			Typ.	Max.	Min.	Typ.	Max.	Min.	Typ.	Max.
QBLP680-RGB1	Red	20	2.0	2.5	615	620	630	500	900	1600
	Green	20	2.9	3.7	520	525	530	1250	2300	4000
	Blue	20	3.0	3.7	465	470	475	200	350	630

Absolute Maximum Rating

Material	P _d (mW)	I _F (mA)	I _{FP} (mA)*	V _R (V)	T _{OP} (°C)	T _{ST} (°C)	T _{SOL} (°C)**
AllnGaP (R)	75	30	100	5	-40 ~ +80	-40 ~ +85	260
InGaN (IG/IB)	111	30	125	5	-40 ~ +80	-40 ~ +85	260

*Duty 1/8 @ 1KHz

**IR Reflow for no more than 10 sec @ 260 °C

Luminous Intensity I_V for Red @ I_F=20mA

Bin	Min.	Max.	Unit
Q	500	630	mcd
R	630	800	
S	800	1000	
T	1000	1250	
U	1250	1600	

Luminous Intensity I_V for True Green @ I_F=20mA

Bin	Min.	Max.	Unit
U	1250	1600	mcd
V	1600	2000	
W	2000	2500	
X	2500	3200	
Y	3200	4000	

Luminous Intensity I_V for Blue @ I_F=20mA

Bin	Min.	Max.	Unit
M	200	250	mcd
N	250	320	
O	320	400	
P	400	500	
Q	500	630	

Dominant Wavelength λ_D for (R) Red @ $I_F=20mA$

Bin	Min.	Max.	Unit
s	615	620	nm
t	620	625	
u	625	630	

Dominant Wavelength λ_D for (IG) True Green @ $I_F=20mA$

Bin	Min.	Max.	Unit
U	520	522.5	nm
V	522.5	525	
W	525	527.5	
X	527.5	530	

Dominant Wavelength λ_D for (IB) Blue @ $I_F=20mA$

Bin	Min.	Max.	Unit
G	465	467.5	nm
H	467.5	470	
I	470	472.5	
J	472.5	475	

Characteristic Curves

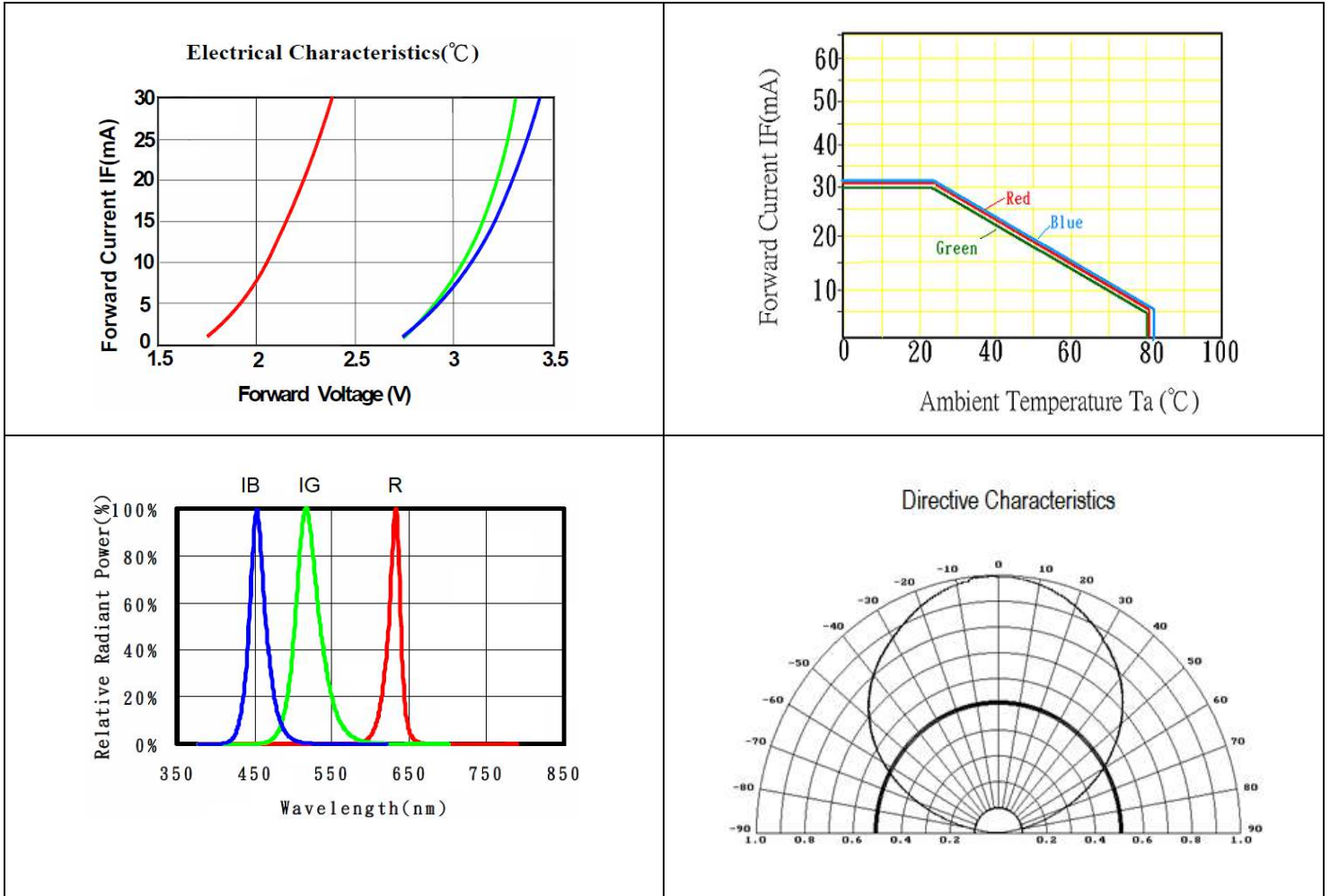

Solder Profile & Footprint

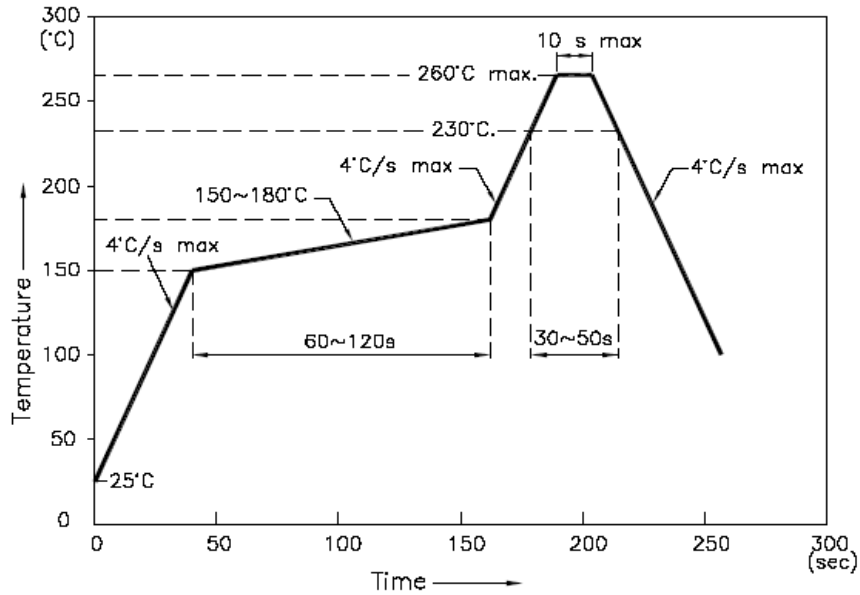

Recommend Soldering Footprint

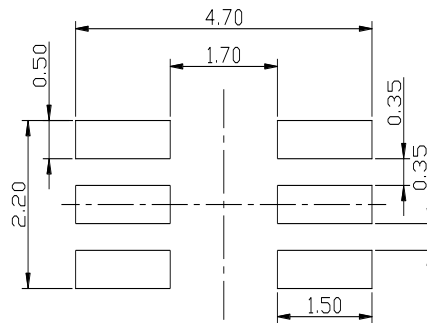

Unit: mm

Packing

Reel Dimension:

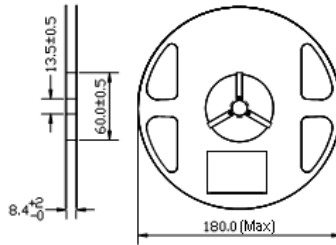

Unit: mm

Tape Dimension:

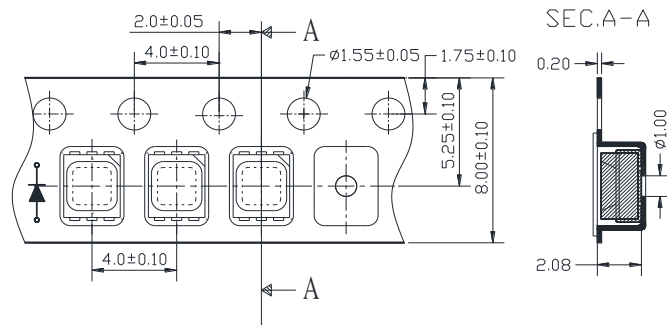

Unit: mm

Arrangement of Tape:

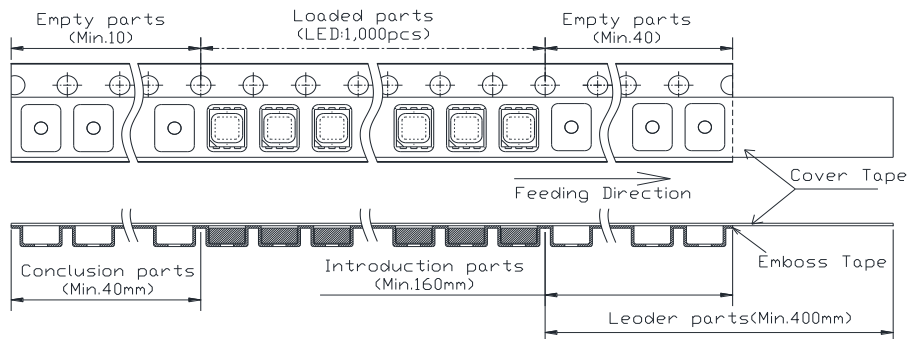



QBLP680-RGB1

PLCC6 RGB LED
BLACK FACE

Ordering Information

Part #	Orderable Part #	Spec Range	Quantity per reel
QBLP680-RGB1	QBLP680-RGB1	Red: $I_v=900\text{mcd typ. @ }20\text{mA}$ / Color: 615 to 630nm	1000 units
		Green: $I_v=2300\text{mcd typ. @ }20\text{mA}$ / Color: 520 to 530nm	
		Blue: $I_v=350\text{mcd typ. @ }20\text{mA}$ / Color: 465 to 475nm	



Revision History

Description:	Revision #	Revision Date
New Release of QBLP680-RGB1	V1.0	07/03/2013
Update drawing and spec	V2.0	11/06/2018
Add Maximum value to the spec	V2.1	12/10/2018

Disclaimer

QT-BRIGHTTEK reserves the right to make changes without further notice to any products herein to improve reliability, function or design. QT-BRIGHTTEK does not assume any liability arising out of the application or use of any product or circuit described herein; neither does it convey any license under its patent rights, nor the rights of others.

Life Support Policy

QT-BRIGHTTEK's products are not authorized for use as critical components in life support devices or systems without the express written approval of QT-BRIGHTTEK. As used herein:

1. Life support devices or systems are devices or systems which, (a) are intended for surgical implant into the body, or (b) support or sustain life, and (c) whose failure to perform when properly used in accordance with instructions for use provided in the labeling, can be reasonably expected to result in a significant injury of the user.
2. A critical component in any component of a life support device or system whose failure to perform can be reasonably expected to cause the failure of the life support device or system, or to affect its safety or effectiveness.