



## MULTIPLIER-DIVIDER

### FEATURES

- LOW COST
- DIFFERENTIAL INPUT
- ACCURACY 100% TESTED AND GUARANTEED
- LOW NOISE  
120 $\mu$ V, rms, 10Hz to 10kHz
- SELF-CONTAINED  
No additional amplifiers
- SMALL SIZE  
Hermetic TO-100 package
- WIDE TEMPERATURE OPERATION

### APPLICATIONS

- MULTIPLICATION
- DIVISION
- SQUARING
- SQUARE ROOT
- LINEARIZATION
- POWER COMPUTATION
- ANALOG SIGNAL PROCESSING
- ALGEBRAIC COMPUTATION
- TRUE RMS-TO-DC CONVERSION

### DESCRIPTION

The 4213 multiplier-divider is a low cost precision device designed for general purpose application. In addition to four-quadrant multiplication, it also performs analog square root and division without the bother of external amplifiers. The 4213 is laser-trimmed to guarantee its rated accuracy with no

external components. The internal zener regulated references make the 4213 much less sensitive to supply variation than earlier IC multipliers. Hermetic TO-100 package, wide operating temperature range, low output noise, and low cost are some of the desirable features of this versatile device.

4213 FUNCTIONAL DIAGRAM

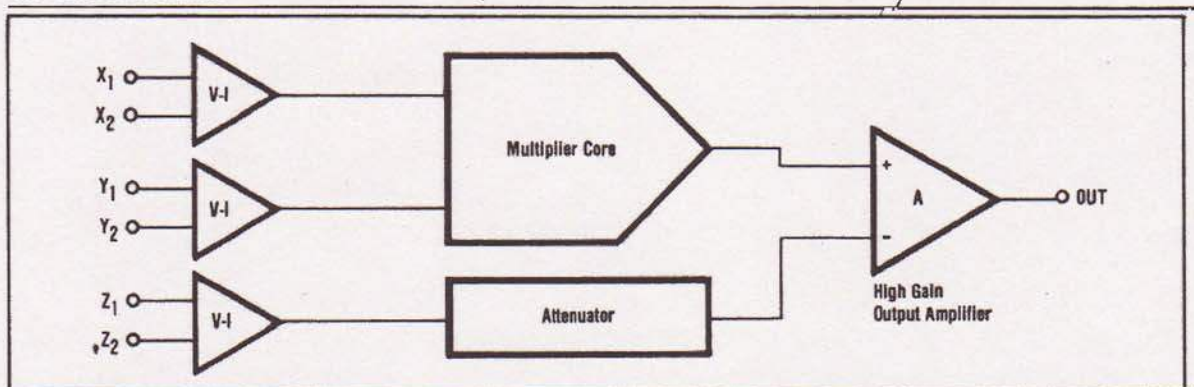

# SPECIFICATIONS

## ELECTRICAL

Specifications at  $T_A = +25^\circ\text{C}$  and  $\pm V_{CC} = 15\text{VDC}$  unless otherwise noted.

MODEL	PARAMETER	CONDITIONS	4213AM			4213BM			4213SM			UNITS
			MIN	TYP	MAX	MIN	TYP	MAX	MIN	TYP	MAX	
<b>MULTIPLIER PERFORMANCE</b>												
	Transfer Function		$\frac{(X_1 - X_2)(Y_1 - Y_2) + Z_2}{10}$									
Total Error		$-10\text{V} \leq X, Y \leq 10\text{V}$ $T_A = +25^\circ\text{C}$			$\pm 1.0$			$\pm 0.5$			$\pm 0.5$	% FSR
Initial vs Temperature		$-25^\circ\text{C} \leq T_A \leq +85^\circ\text{C}$	$\pm 0.008$		$\pm 0.02$							% FSR/ $^\circ\text{C}$
vs Temperature vs Supply		$-55^\circ\text{C} \leq T_A \leq +125^\circ\text{C}$	--		--			--		$\pm 0.025$	$\pm 0.05$	% FSR/ $^\circ\text{C}$
Individual Errors			$\pm 0.05$									% FSR/%
Output Offset												mV
Initial vs Temperature		$T_A = +25^\circ\text{C}$	$\pm 10$		$\pm 50$		$\pm 7$	$\pm 25$		$\pm 7$	$\pm 25$	mV/ $^\circ\text{C}$
vs Temperature vs Supply		$-25^\circ\text{C} \leq T_A \leq +85^\circ\text{C}$	$\pm 0.7$		$\pm 2.0$		$\pm 0.3$	$\pm 0.7$		--	--	mV/ $^\circ\text{C}$
Scale Factor Error		$-55^\circ\text{C} \leq T_A \leq +125^\circ\text{C}$	--		--		--	--		$\pm 0.3$	$\pm 0.7$	mV/%
Initial vs Temperature		$T_A = +25^\circ\text{C}$	$\pm 0.12$									% FSR
vs Temperature vs Supply		$-25^\circ\text{C} \leq T_A \leq +85^\circ\text{C}$	$\pm 0.008$									% FSR/ $^\circ\text{C}$
Nonlinearity		$-55^\circ\text{C} \leq T_A \leq +125^\circ\text{C}$	--		--			--		$\pm 0.008$		% FSR/ $^\circ\text{C}$
X Input			$\pm 0.05$									% FSR/%
Y Input												% FSR
Feedthrough		$X = 20\text{V}, \text{p-p}; Y = \pm 10\text{VDC}$	$\pm 0.08$									% FSR
X Input		$Y = 20\text{V}, \text{p-p}; X = \pm 10\text{VDC}$	$\pm 0.01$									% FSR
Y Input		$f = 50\text{Hz}$										
vs Temperature		$X = 20\text{V}, \text{p-p}; Y = 0$	30									mV, p-p
vs Supply		$Y = 20\text{V}, \text{p-p}; X = 0$	6									mV, p-p
		$-25^\circ\text{C} \leq T_A \leq +85^\circ\text{C}$	0.1									mV, p-p/ $^\circ\text{C}$
		$-55^\circ\text{C} \leq T_A \leq +125^\circ\text{C}$	--		--			--		0.1		mV, p-p/ $^\circ\text{C}$
			0.15									mV, p-p/%
<b>DIVIDER PERFORMANCE</b>												
	Transfer Function	$X_1 > X_2$	$\frac{10(Z_1 - Z_2)}{(X_1 - X_2)} + Y_2$									
Total Error (with external adjustments)		$X = -10\text{V}$ $-10\text{V} \leq Z \leq +10\text{V}$ $X = -1\text{V}$ $-1\text{V} \leq Z \leq +1\text{V}$ $-10\text{V} \leq X \leq -0.2\text{V}$ $-10\text{V} \leq Z \leq +10\text{V}$	$\pm 0.75$				$\pm 0.35$			$\pm 0.35$		% FSR
			$\pm 2.0$				$\pm 1.0$			$\pm 1.0$		% FSR
			$\pm 5.0$				$\pm 1.0$			$\pm 1.0$		% FSR
<b>SQUARER PERFORMANCE</b>												
	Transfer Function		$\frac{(X_1 - X_2)^2}{10} + Z_2$									
Total Error		$-10\text{V} \leq X \leq +10\text{V}$	$\pm 0.6$				$\pm 0.3$			$\pm 0.3$		% FSR
<b>SQUARE-ROOTER PERFORMANCE</b>												
	Transfer Function	$Z_1 < Z_2$	$+\sqrt{10(Z_2 - Z_1)}$									
Total Error		$1\text{V} \leq Z \leq 10\text{V}$	$\pm 1$				$\pm 0.5$			$\pm 0.5$		% FSR
<b>AC PERFORMANCE</b>												
Small-Signal Bandwidth		$\pm 3\text{dB}$	550									kHz
1% Amplitude Error		Small Signal	70									kHz
1% (0.57°) Vector Error		Small Signal	5									kHz
Full Power Bandwidth		$ V_d  = 10\text{V}, R_L = 2\text{k}\Omega$	320									kHz
Slew Rate		$ V_d  = 10\text{V}, R_L = 2\text{k}\Omega$	20									V/ $\mu\text{sec}$
Settling Time		$\epsilon = \pm 1\%, \Delta V_o = 20\text{V}$	2									$\mu\text{sec}$
Overload Recovery		50% Output Overload	0.2									$\mu\text{sec}$
<b>INPUT CHARACTERISTICS</b>												
Input Voltage Range			$\pm 10$									V
Rated Operation					$\pm V_{CC}$							V
Absolute Maximum												V
Input Resistance		X, Y, Z (1)	10									M $\Omega$
Input Bias Current		X, Y, Z	1.4									$\mu\text{A}$
<b>OUTPUT CHARACTERISTICS</b>												
Rated Output Voltage		$I_o = \pm 5\text{mA}$	$\pm 10$									V
Current		$V_o = \pm 10\text{V}$	$\pm 5$									mA
Output Resistance		$f = \text{DC}$	1.5									$\Omega$
<b>OUTPUT NOISE VOLTAGE</b> - X = Y = 0												
$f_o = 1\text{Hz}$			40									$\mu\text{V}/\sqrt{\text{Hz}}$
$f_o = 10\text{kHz}$			1.0									$\mu\text{V}/\sqrt{\text{Hz}}$
1/f Corner Frequency			1060									Hz
$f_B = 10\text{Hz to } 10\text{kHz}$			125									$\mu\text{V, rms}$
$f_B = 10\text{Hz to } 10\text{MHz}$			3									mV, rms
<b>POWER SUPPLY REQUIREMENTS</b>												
Rated Voltage			$\pm 8.5$		$\pm 15$							VDC
Operating Range		Derated Performance			$\pm 20$							VDC
Quiescent Current					$\pm 5.5$							mA

# ELECTRICAL (CONT)

MODEL	PARAMETER	CONDITIONS	4213AM			4213BM			4213SM			UNITS
			MIN	TYP	MAX	MIN	TYP	MAX	MIN	TYP	MAX	
TEMPERATURE RANGE (Ambient)												
Specification			-25		+85	.		.				°C
Operating Range		Derated Performance	-55		+125	.		.			+125	°C
Storage			-65		+150	.		.			.	°C

**NOTES:**

1. Z<sub>2</sub> input resistance is 10MΩ, typical, with Pin 9 open. If Pin 9 is grounded or used for optional offset adjustment, the Z<sub>2</sub> input resistance may be as low as 25kΩ.

\*Same as 4213AM specification.

The information provided herein is believed to be reliable; however, BURR-BROWN assumes no responsibility for inaccuracies or omissions. BURR-BROWN assumes no responsibility for the use of this information, and all use of such information shall be entirely at the user's own risk. Prices and specifications are subject to change without notice. No patent rights or licenses to any of the circuits described herein are implied or granted to any third party. BURR-BROWN does not authorize or warrant any BURR-BROWN product for use in life support devices and/or systems.

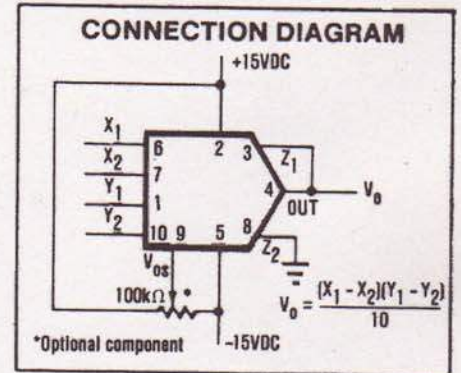

### MECHANICAL

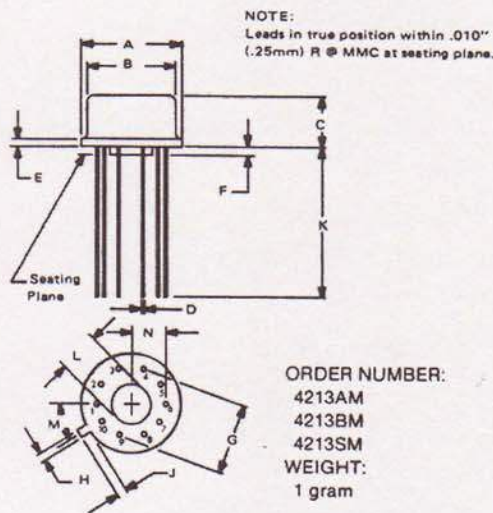

DIM	INCHES		MILLIMETERS	
	MIN	MAX	MIN	MAX
A	.335	.370	8.51	9.40
B	.305	.335	7.75	8.51
C	.165	.185	4.19	4.70
D	.016	.021	0.41	0.53
E	.010	.040	0.25	1.02
F	.010	.040	0.25	1.02
G	.230 BASIC		5.84 BASIC	
H	.028	.034	0.71	0.86
J	.029	.045	0.74	1.14
K	.500	--	12.70	--
L	.120	.160	3.05	4.06
M	36° BASIC		36° BASIC	
N	.110	.120	2.79	3.05

### PIN CONFIGURATION

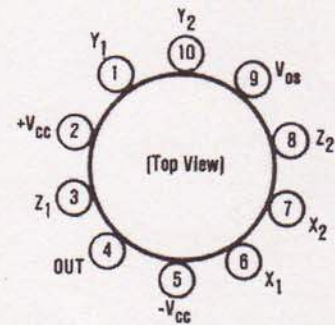

**NOTES:**

- V<sub>OS</sub> adjustment optional not normally recommended. V<sub>OS</sub> pin may be left open or grounded.
- All unused input pins should be grounded.
- Pin 5 is connected to the case.

### SIMPLIFIED SCHEMATIC

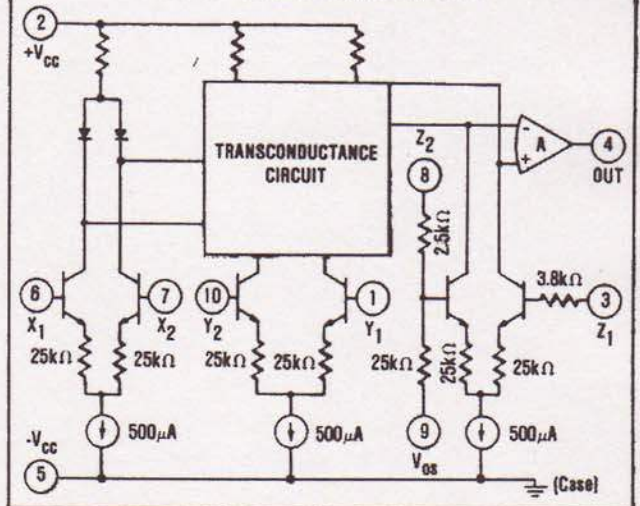

# TYPICAL PERFORMANCE CURVES

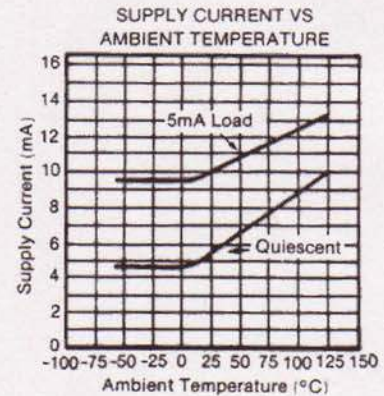
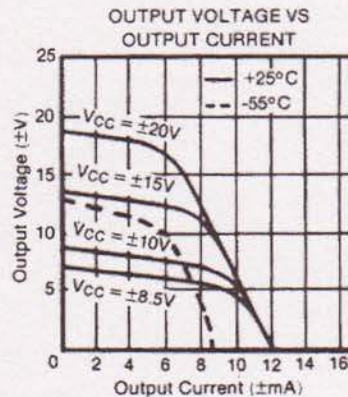
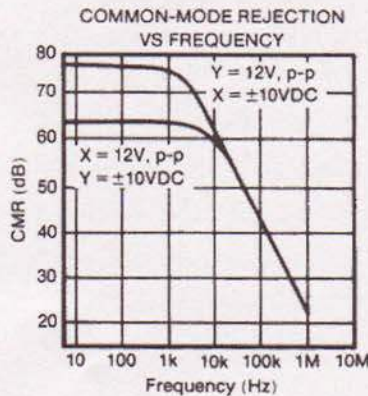
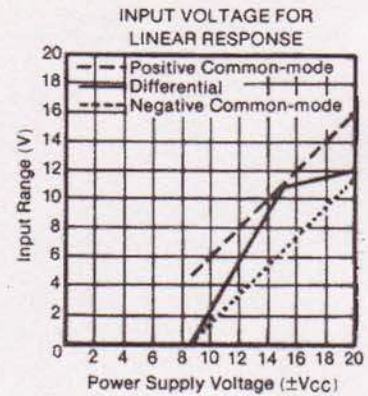
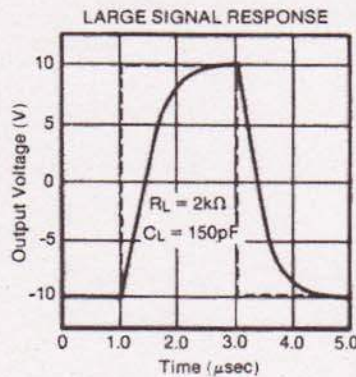
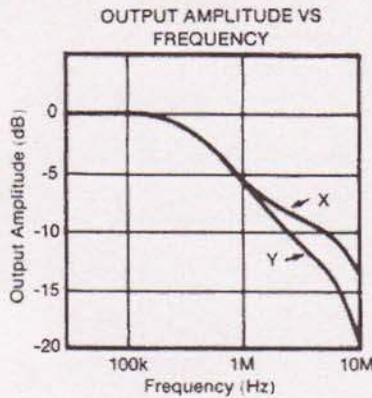
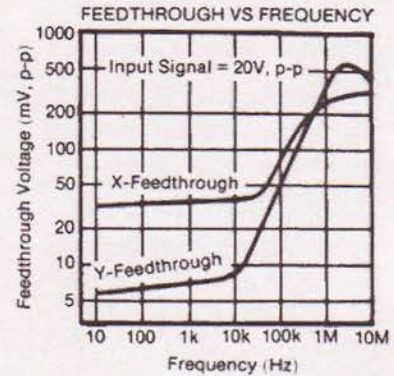
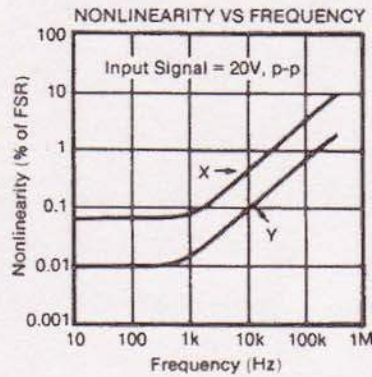
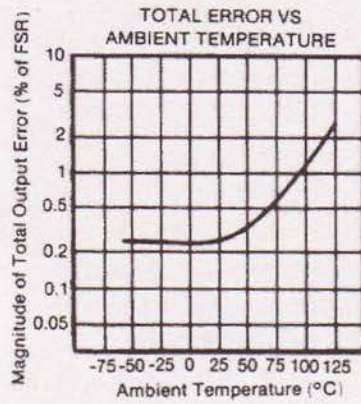

## ABSOLUTE MAXIMUM RATINGS

Supply	±20VDC
Internal Power Dissipation <sup>(1)</sup>	500mW
Differential Input Voltage <sup>(2)</sup>	±40VDC
Input Voltage Range <sup>(2)</sup>	±20VDC
Storage Temperature Range	-65°C to +150°C
Operating Temperature Range	-55°C to +125°C
Lead Temperature (soldering, 10 seconds)	+300°C
Output Short-circuit Duration <sup>(3)</sup>	Continuous
Junction Temperature	+150°C

### NOTES:

- Package must be derated based on:  $\theta_{JC} = 55^\circ\text{C/W}$  and  $\theta_{JA} = 165^\circ\text{C/W}$ .
- For supply voltages less than ±20VDC the absolute maximum input voltage is equal to the supply voltage.
- Short-circuit may be to ground only. Rating applies to +85°C ambient.

# DEFINITIONS

## TOTAL ERROR (Accuracy)

Total error is the actual departure of the multiplier output voltage from the ideal product of its input voltages. It includes the sum of the effects of input and output DC offsets, gain error and nonlinearity.

## OUTPUT OFFSET

Output offset is the output voltage when both inputs  $V_X$  and  $V_Y$  are zero volts.

## SCALE FACTOR ERROR

Scale factor error is the difference between the actual scale factor and the ideal scale factor.

## NONLINEARITY

Nonlinearity is the maximum deviation from a best straightline (curve fitting on input-output graph) expressed as a percent of peak-to-peak full scale output.

## FEEDTHROUGH

Feedthrough is the signal at the output for any value of  $V_X$  or  $V_Y$  within the rated range, when the other input is zero.

## SMALL SIGNAL BANDWIDTH

Small signal bandwidth is the frequency at which the output is down 3dB from its low frequency value for a nominal output amplitude of 10% of full scale.

## 1% AMPLITUDE ERROR

The 1% amplitude error is the frequency the output amplitude is in error by 1%, measured with an output amplitude of 10% of full scale.

## 1% VECTOR ERROR

The 1% vector error is the frequency at which a phase error of 0.01 radians (0.57°) occurs. This is the most sensitive measure of dynamic error of a multiplier.

# APPLICATIONS INFORMATION

## MULTIPLICATION

Figure 1 shows the basic connection for four-quadrant multiplication.

The 4213 meets all of its specifications without trimming. Accuracy can, however, be improved by nulling the output offset voltage using the 100kΩ optional balance potentiometer shown in Figure 1.

AC feedthrough may be reduced to a minimum by applying an external voltage to the X or Y input as shown in Figure 2.

$Z_2$ , the optional summing input, may be used to sum a voltage into the output of the 4213. If not used, this

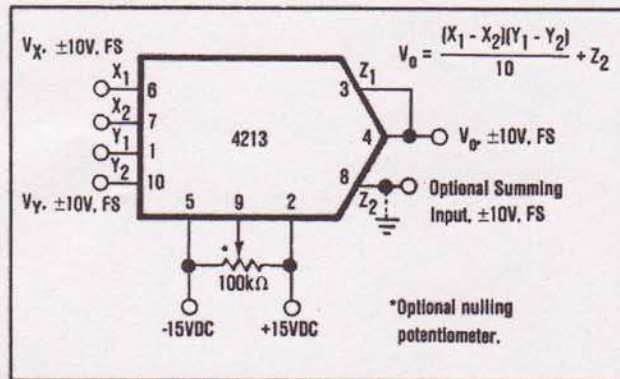

FIGURE 1 Multiplier Connection.

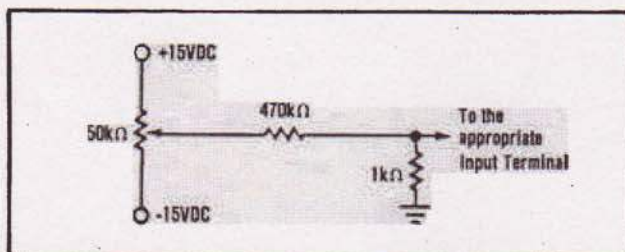

FIGURE 2. Optional Trimming Configuration.

terminal, as well as the X and Y input terminals, should be grounded. All inputs should be referenced to power supply common.

Figure 3 shows how to achieve a scale factor larger than the nominal 0.1. In this case, the scale factor is unity which makes the transfer function

$$V_o = KV_X V_Y = K(X_1 - X_2)(Y_1 - Y_2)$$

$$K = [1 + (R_1/R_2)]/10$$

$$0.1 \leq K \leq 1$$

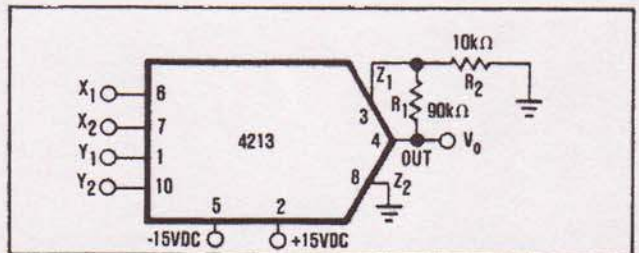

FIGURE 3. Connection For Unity Scale Factor.

This circuit has the disadvantage of increasing the output offset voltage by a factor of 10 which may require the use of the optional balance control for some applications. In addition, this connection reduces the small signal bandwidth to about 50kHz.

## DIVISION

Figure 4 shows the basic connection for two-quadrant division. This configuration is a multiplier-inverted analog divider, i.e., a multiplier connected in the feedback loop of an operational amplifier. In the case of the 4213 this operational amplifier is the output amplifier of the multiplier itself.

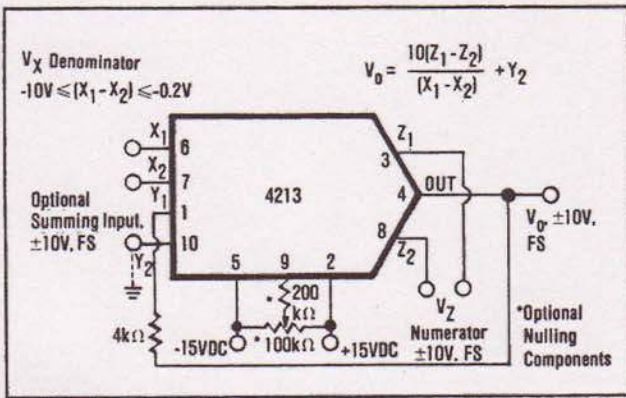

FIGURE 4. Divider Connection.

The divider error with a multiplier-inverted analog divider is approximately

$$\epsilon_{\text{divider}} = 10 \epsilon_{\text{multiplier}} / (X_1 - X_2).$$

It is obvious from this error equation that divider error becomes excessively large for small values of  $X_1 - X_2$ . A 10-to-1 denominator range is usually the practical limit. If more accurate division is required over a wide range of denominator voltages, an externally generated voltage may be applied to the unused X-input (see Optional Trim Configuration). To trim, apply a ramp of +100mV to +1V at 100Hz to both  $X_1$  and  $Z_1$  if  $X_2$  is used for offset adjustment, otherwise reverse the signal polarity, and adjust the trim voltage to minimize the variation in the output. An alternative to this procedure would be to use the Burr-Brown DIV100, a precision log-antilog divider.

### SQUARING

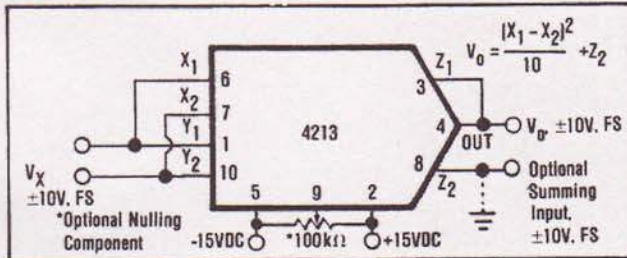

FIGURE 5. Squarer Connection.

### SQUARE ROOT

Figure 6 shows the connection for taking the square root of the voltage  $V_Z$ . The diode prevents a latching condition which could occur if the input momentarily changed polarity. This latching condition is not a design flaw in the 4213, but occurs when a multiplier is connected in the feedback loop of an operational amplifier to perform square root functions.

The load resistance  $R_L$  must be in the range of  $10k\Omega \leq R_L \leq 1M\Omega$ . This resistance must be in the circuit as it provides the current necessary to operate the diode.

The output offset should be nulled for optimum performance by allowing the input to be its smallest expected value and adjusting  $R_1$  for the proper output voltage.

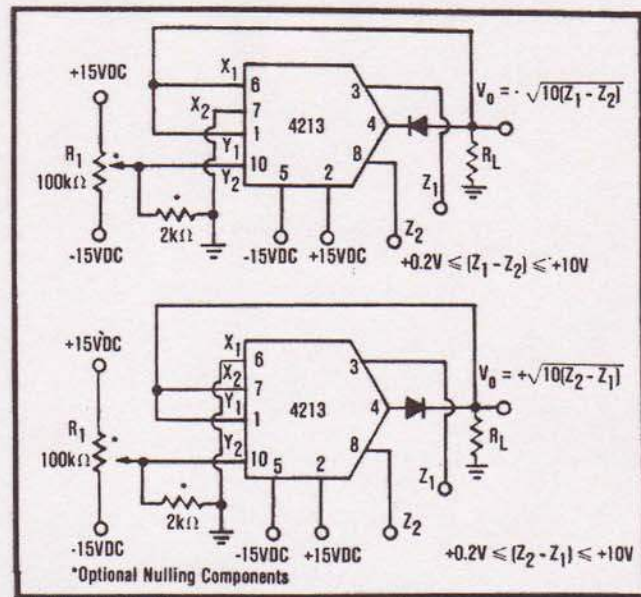

FIGURE 6. Square Root Connection.

This will improve the square root mode accuracy to about that of the multiply mode.

### BRIDGE LINEARIZATION

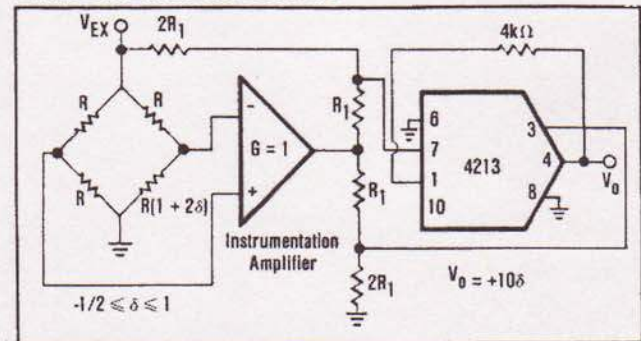

FIGURE 7. Bridge Linearization.

The use of the 4213 and the instrumentation amplifier to linearize the output from a bridge circuit makes the output  $V_o$  independent of the bridge supply voltage.

### TRUE RMS-TO-DC CONVERSION

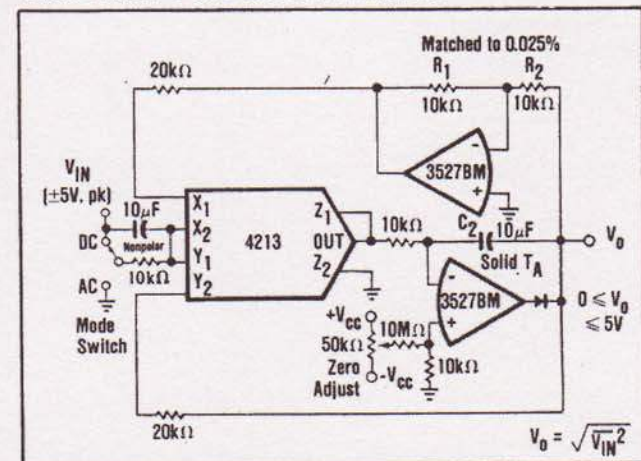

FIGURE 8. True RMS-to-DC Conversion.

The RMS-to-DC conversion circuit of Figure 8 gives greater accuracy and bandwidth but with less dynamic range than most rms-to-DC converters.

### PERCENTAGE COMPUTATION

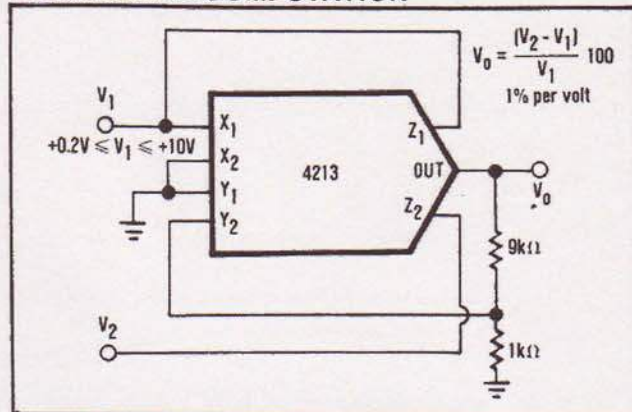

FIGURE 9. Percentage Computation.

The circuit of Figure 9 has a sensitivity of 1V/% and is capable of measuring 10% deviations. Wider deviation can be measured by decreasing the ratio of  $R_2/R_1$ .

### SINE FUNCTION GENERATOR

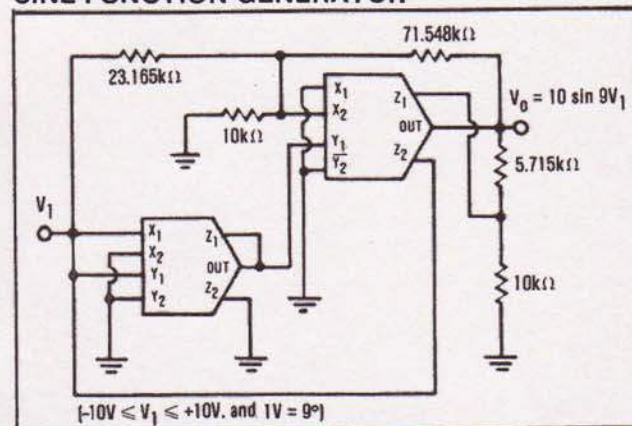

FIGURE 10. Sine Function Generator.

The circuit in Figure 10 uses implicit feedback to implement the following sine function approximation:

$$V_o = (1.5715V_1 - 0.004317V_1^3) / (1 + 0.001398V_1^2) = 10 \sin(9V_1)$$

### SINGLE-PHASE POWER MEASUREMENT

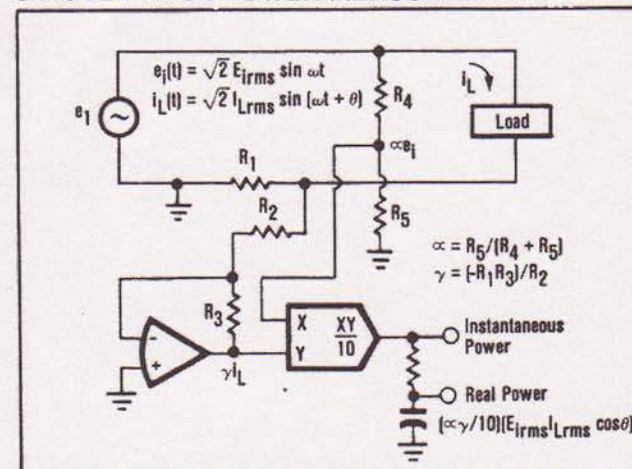

FIGURE 11. Single-Phase Instantaneous and Real Power Measurement.

### WIRING PRECAUTIONS

In order to prevent frequency instability due to lead inductance of the power supply lines, each power supply should be bypassed. This should be done by connecting a 10μF tantalum capacitor in parallel with a 1000pF ceramic capacitor from the +V<sub>CC</sub> and -V<sub>CC</sub> pins of the 4213 to the power supply common. The connection of these capacitors should be as close to the 4213 as practical.

### CAPACITIVE LOADS

Stable operation is maintained with capacitive loads to 1000pF in all modes typically, except the square root mode for which 50pF is a safe upper limit. Higher capacitive loads can be driven if a 100Ω resistor is connected in series with the 4213's output.

### MORE CIRCUITS

The theory and procedures for developing virtually any function generator or linearization circuit can be found in the Burr-Brown/ McGraw Hill book "FUNCTION CIRCUITS - Design and Applications."

## IMPORTANT NOTICE

Texas Instruments Incorporated and its subsidiaries (TI) reserve the right to make corrections, modifications, enhancements, improvements, and other changes to its products and services at any time and to discontinue any product or service without notice. Customers should obtain the latest relevant information before placing orders and should verify that such information is current and complete. All products are sold subject to TI's terms and conditions of sale supplied at the time of order acknowledgment.

TI warrants performance of its hardware products to the specifications applicable at the time of sale in accordance with TI's standard warranty. Testing and other quality control techniques are used to the extent TI deems necessary to support this warranty. Except where mandated by government requirements, testing of all parameters of each product is not necessarily performed.

TI assumes no liability for applications assistance or customer product design. Customers are responsible for their products and applications using TI components. To minimize the risks associated with customer products and applications, customers should provide adequate design and operating safeguards.

TI does not warrant or represent that any license, either express or implied, is granted under any TI patent right, copyright, mask work right, or other TI intellectual property right relating to any combination, machine, or process in which TI products or services are used. Information published by TI regarding third-party products or services does not constitute a license from TI to use such products or services or a warranty or endorsement thereof. Use of such information may require a license from a third party under the patents or other intellectual property of the third party, or a license from TI under the patents or other intellectual property of TI.

Reproduction of TI information in TI data books or data sheets is permissible only if reproduction is without alteration and is accompanied by all associated warranties, conditions, limitations, and notices. Reproduction of this information with alteration is an unfair and deceptive business practice. TI is not responsible or liable for such altered documentation. Information of third parties may be subject to additional restrictions.

Resale of TI products or services with statements different from or beyond the parameters stated by TI for that product or service voids all express and any implied warranties for the associated TI product or service and is an unfair and deceptive business practice. TI is not responsible or liable for any such statements.

TI products are not authorized for use in safety-critical applications (such as life support) where a failure of the TI product would reasonably be expected to cause severe personal injury or death, unless officers of the parties have executed an agreement specifically governing such use. Buyers represent that they have all necessary expertise in the safety and regulatory ramifications of their applications, and acknowledge and agree that they are solely responsible for all legal, regulatory and safety-related requirements concerning their products and any use of TI products in such safety-critical applications, notwithstanding any applications-related information or support that may be provided by TI. Further, Buyers must fully indemnify TI and its representatives against any damages arising out of the use of TI products in such safety-critical applications.

TI products are neither designed nor intended for use in military/aerospace applications or environments unless the TI products are specifically designated by TI as military-grade or "enhanced plastic." Only products designated by TI as military-grade meet military specifications. Buyers acknowledge and agree that any such use of TI products which TI has not designated as military-grade is solely at the Buyer's risk, and that they are solely responsible for compliance with all legal and regulatory requirements in connection with such use.

TI products are neither designed nor intended for use in automotive applications or environments unless the specific TI products are designated by TI as compliant with ISO/TS 16949 requirements. Buyers acknowledge and agree that, if they use any non-designated products in automotive applications, TI will not be responsible for any failure to meet such requirements.

Following are URLs where you can obtain information on other Texas Instruments products and application solutions:

### Products

Amplifiers	<a href="http://amplifier.ti.com">amplifier.ti.com</a>
Data Converters	<a href="http://dataconverter.ti.com">dataconverter.ti.com</a>
DLP® Products	<a href="http://www.dlp.com">www.dlp.com</a>
DSP	<a href="http://dsp.ti.com">dsp.ti.com</a>
Clocks and Timers	<a href="http://www.ti.com/clocks">www.ti.com/clocks</a>
Interface	<a href="http://interface.ti.com">interface.ti.com</a>
Logic	<a href="http://logic.ti.com">logic.ti.com</a>
Power Mgmt	<a href="http://power.ti.com">power.ti.com</a>
Microcontrollers	<a href="http://microcontroller.ti.com">microcontroller.ti.com</a>
RFID	<a href="http://www.ti-rfid.com">www.ti-rfid.com</a>
RF/IF and ZigBee® Solutions	<a href="http://www.ti.com/lprf">www.ti.com/lprf</a>

### Applications

Audio	<a href="http://www.ti.com/audio">www.ti.com/audio</a>
Automotive	<a href="http://www.ti.com/automotive">www.ti.com/automotive</a>
Broadband	<a href="http://www.ti.com/broadband">www.ti.com/broadband</a>
Digital Control	<a href="http://www.ti.com/digitalcontrol">www.ti.com/digitalcontrol</a>
Medical	<a href="http://www.ti.com/medical">www.ti.com/medical</a>
Military	<a href="http://www.ti.com/military">www.ti.com/military</a>
Optical Networking	<a href="http://www.ti.com/opticalnetwork">www.ti.com/opticalnetwork</a>
Security	<a href="http://www.ti.com/security">www.ti.com/security</a>
Telephony	<a href="http://www.ti.com/telephony">www.ti.com/telephony</a>
Video & Imaging	<a href="http://www.ti.com/video">www.ti.com/video</a>
Wireless	<a href="http://www.ti.com/wireless">www.ti.com/wireless</a>

Mailing Address: Texas Instruments, Post Office Box 655303, Dallas, Texas 75265  
Copyright © 2009, Texas Instruments Incorporated