

© - TE Connectivity. All Rights Reserved.

REVISIONS

| P | LTR | DESCRIPTION | DATE | DWN | APVD |
|---|-----|---------------------------|-----------|-----|------|
| | L3 | REVISED PER ECN-22-156403 | 03JUN2022 | RK | CSD |

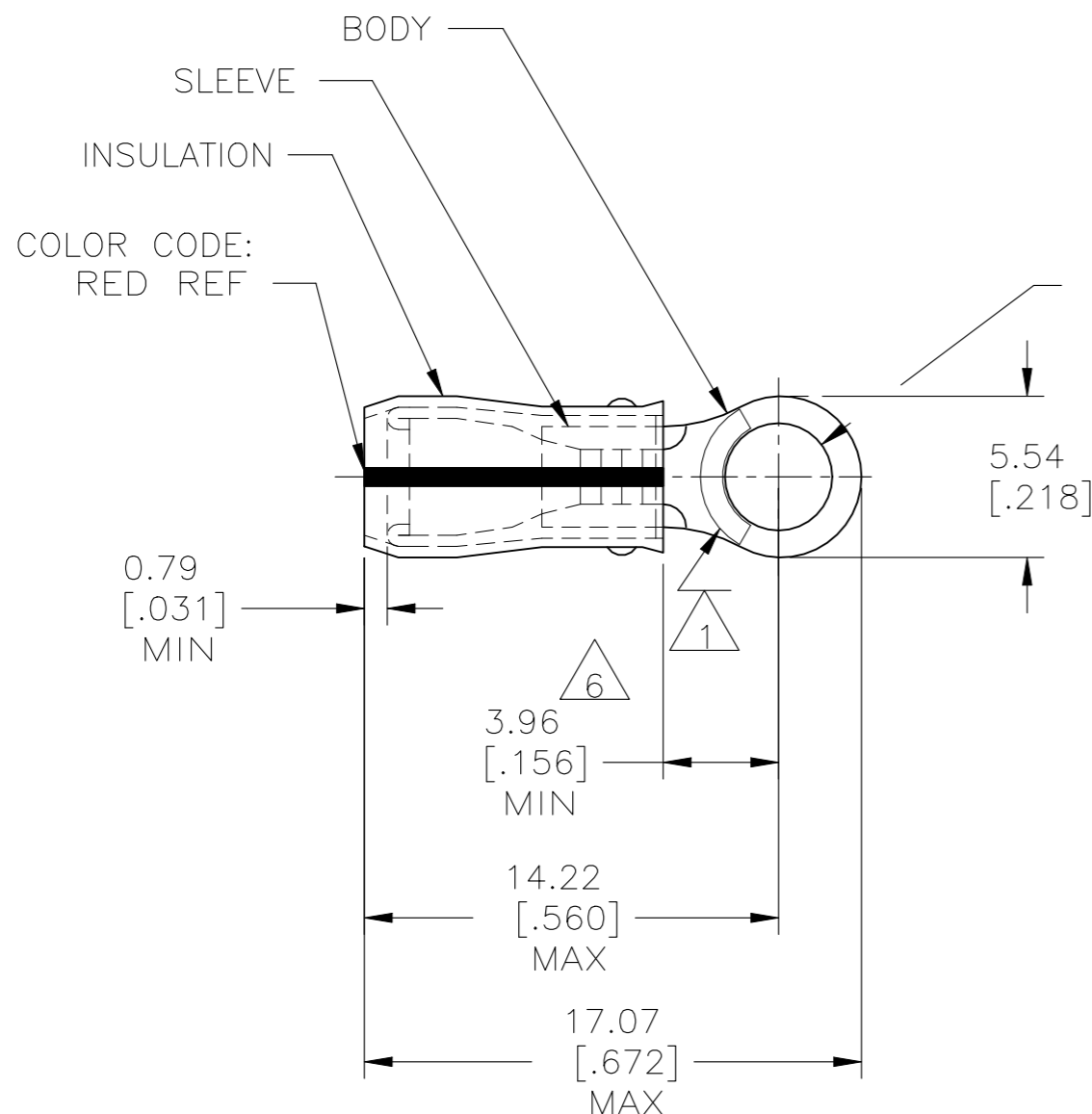

$\phi 3.68 \pm 0.08$
 $[\phi .145 \pm .003]$
 FOR M3.5[#6] STUD

- 1 STAMP AMP 22-18* APPROX AS SHOWN
22-16 TERMINALS ARE STAMPED 22-18 IN ACCORDANCE WITH MILITARY SPEC SAE AS7928 COMMERCIAL WIRE RANGE IS 22-16.
- 2 WIRE INSULATION DIA: 2.03-3.18 [.080-.125]
- 3 TONGUE MATERIAL THK: 0.79±0.05 [.031±.002]
- 4 BODY & SLEEVE: TIN/LEAD (93-7) PLATE PER ASTM B545, (3% MIN LEAD CONTENT)
- 5 BODY & SLEEVE- CU PER ASTM B152 INSULATION - PVF2, COLOR - NATURAL
- 6 DIMENSION APPLIES FROM EDGE OF METAL WIRE BARREL TO CENTER OF STUD HOLE.

| | | | |
|---|------|------------------|-----------|
| - | 100 | LOOSE PIECE, BOX | 8-53406-1 |
| M7928/4-101, CLASS 1 M7928/13-101, CLASS 1 | 1000 | LOOSE PIECE | 53406-1 |
| MILITARY P/N & CLASS | QTY | PACKAGE TYPE | PART NO. |

| | | | | | | | | | | | | | | | |
|--|--|---|--|--|------------------------------|---|---------------|-------|-----------|---------------------------|---------------|------------------|---------------|-----|----|
| AMP INCORPORATED CUSTOMER SERVICE SYSTEMS | | MAX RECOMMENDED OPERATING TEMPERATURE: 150°C[302°F] MAX | THIS DRAWING IS A CONTROLLED DOCUMENT. | | DWN DK SCHRUM 06/16/93 | TE Connectivity NAME TERMINAL, RING TONGUE, PVF2, P.I.D.G. WIRE SIZE: 22-16 AWG | | | | | | | | | |
| FOR ADDITIONAL PRODUCT INFORMATION OR COPIES OF DRAWINGS AND TECHNICAL DOCUMENTS | PRODUCT INFORMATION CENTER 1-800-522-6752 | VOLTAGE RATING: N/A | DIMENSIONS: mm [INCHES] | TOLERANCES UNLESS OTHERWISE SPECIFIED: | CHK RE HERSEY 7/6/93 | | | | | APVD M ELLIS 7/6/93 | PRODUCT SPEC | APPLICATION SPEC | RESTRICTED TO | | |
| FOR APPLICATION TOOLING INFORMATION | TOOLING ASSISTANCE CENTER 1-800-722-1111 | CIRCULAR MIL AREA: 0.26-1.65mm²[509-3260] STRANDED | | 0 PLC ± - 1 PLC ± - 2 PLC ± 0.20[.008] 3 PLC ± - 4 PLC ± - ANGLES ± - | PRODUCT SPEC | APPLICATION SPEC | NOT AVAILABLE | SIZE | CAGE CODE | DRAWING NO | RESTRICTED TO | | | | |
| FOR ORDER ENTRY | 1-800-526-5142 | THIS DRAWING IS A CONTROLLED DOCUMENT FOR AMP INCORPORATED. IT IS SUBJECT TO CHANGE AND THE CONTROLLING ENGINEERING ORGANIZATION SHOULD BE CONTACTED FOR THE LATEST REVISION. | MATERIAL | FINISH | WEIGHT | - | A3 | 00779 | C-53406 | SCALE | 4:1 | SHEET | 1 OF 1 | REV | L3 |