

VL6180X plug-in and STM32 F401RE Nucleo board explorer kit

Data brief

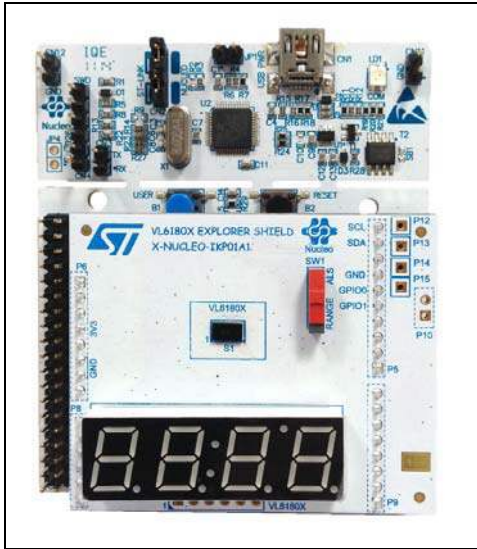

Features

- 1 Nucleo board with STM32 F401RE microcontroller in LQFP64 package
 - Flexible board power supply
 - USB VBUS or external source (3.3 V, 5 V, 7 - 12 V)
 - Power management access point
- 1 VL6180X (proximity, gesture and ambient light sensing module) plug-in.
 - Slider switch controlling 2 functions:
 - Ranging measurement.
 - Ambient light sensing, up to 100KLux.^(a)
 - 4-digit display, displaying either the distance of a target from the proximity sensor or the lux value from the ambient light sensing (ALS).
 - Excellent ranging accuracy, independent of the reflectance of the target.

a. VL6180X detects up to 100KLux but since the display is 4 digits only, maximum displayed value is limited to 9999 Lux

- Equipped with Arduino UNO R3 connector.
- RoHS compliant.
- Full system SW supplied, download from www.st.com/vl6180x in the folder "Design resources."
- VL6180X satellite board^(b) can be soldered to the plug-in board through flying wires, in order to integrate the VL6180X in customer's application.
- Basic gesture recognition application can be developed using the VL6180X sensor on the plug-in board or a dual sensor application by connecting a VL6180X satellite to the board.

Description

The EVALKIT-VL6180X is an evaluation kit that provides an introduction to the proximity, ranging and light sensing capabilities of the VL6180X sensor, combined with the powerful STM32 F401RE microcontroller.

The STM32 Nucleo board provides an affordable and flexible way for users to try out new ideas and build prototypes with any STM32 microcontroller line, choosing from the various combinations of performance, power consumption and features. The Arduino™ connectivity support and ST Morpho headers make it easy to expand the functionality of the STM32 Nucleo open development platform with a wide choice of specialized expansion boards.

The VL6180X plug-in features the VL6180X proximity sensor, based on ST's FlightSense™, Time-of-Flight technology, and provides very accurate ranging information, as well as ambient light sensing (ALS) information. The range measurements are independent of the target reflectance.

b. Order code: VL6180X-SATEL

1 Ordering information

Table 1. Ordering code

Order code	Description
EVALKIT-VL6180X	VL6180X plug-in and STM32 F401RE Nucleo board

2 STM32 F401RE board

Information for STM32 F401RE can be found in the user manual UM1724 STM32™ Nucleo boards.

http://www.st.com/st-web-ui/static/active/en/resource/technical/document/user_manual/DM00105823.pdf

3 VL6180X plug-in board

This section describes the VL6180X plug-in board features and provides information which could be useful for understanding the electrical schematics.

3.1 Description

The board allows the user to test the VL6180X functionality, to program it and to help understanding how to develop an application using VL6180X. It integrates:

- a 4-Digit display to render either the Range value in mm either the Ambient Light value in Lux
- a switch to select the value type to be displayed
- a 2.8V regulator to supply the VL6180X
- two level shifters to adapt the I/O level to the micro controller main board
- the necessary connectivity for the application.

To control the VL6180X through the I2C bus and drive the 4-digit display on board, a firmware for NUCLEO-F401RE, an example of C-ANSI source code and an installation user manual are available on www.st.com/vl6180x in the folder "Design resources".

The VL6180X plug-in board and STM32 Nucleo are connected through Arduino compatible connectors CN5, CN6, CN8 and CN9 as described in [Table 3](#) and [Table 4](#).

The Arduino connectors on STM32 Nucleo board support Arduino Uno Revision 3.

The VL6180X plug-in board allows connecting a VL6180X satellite board^(c) by soldering some wires on the 6-pin header located below the 4-digit display (see *Figure 1*). This VL6180X satellite can be used as a secondary sensor to run a dual sensor application or can be used as a physically deported single sensor. Three pins are common with the VL6180X on-board: I2C bus and GPIO1 (Interrupt) pins. GPIO0 are separate pins to control each sensor separately. Be aware the I/O named GPIO0_EXT for external VL6180X, connected to the micro-controller board is not connected to a level shifter. Refer to *Figure 5* and *Figure 6* for detailed connectivity.

Figure 1. Connections of a VL6180X satellite on VL6180X plug-in board

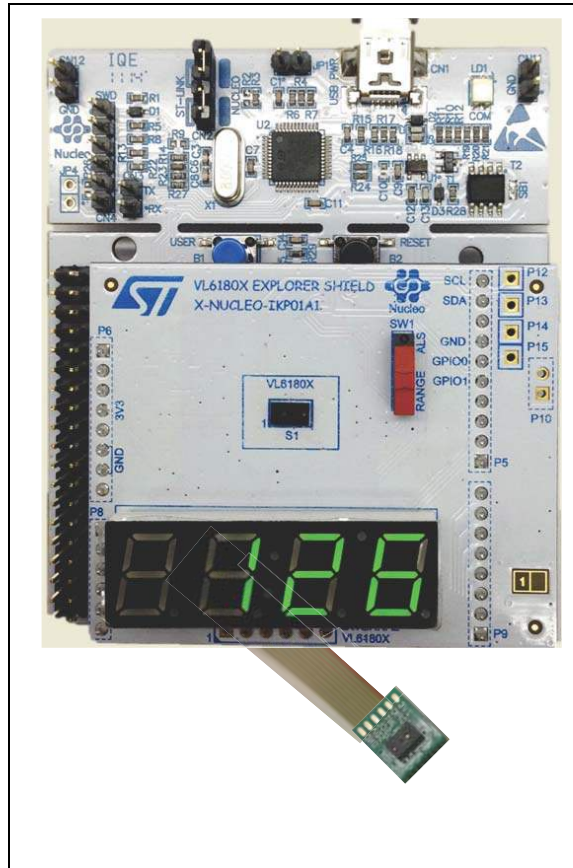

Note: The setting of a second VL6180X is not yet available in the current PC software graphical user interface (GUI). It will be embedded in the next release.

VL6180X satellite ordering code on www.st.com/vl6180x : VL6180X-SATEL

c. Order code: VL6180X-SATEL

3.2 Electrical schematics and list of material

The figures and tables of this section describe the electrical schematics for each type of functions of the board and the list of material associated.

Figure 2. VL6180X plug-in board - VL6180X application

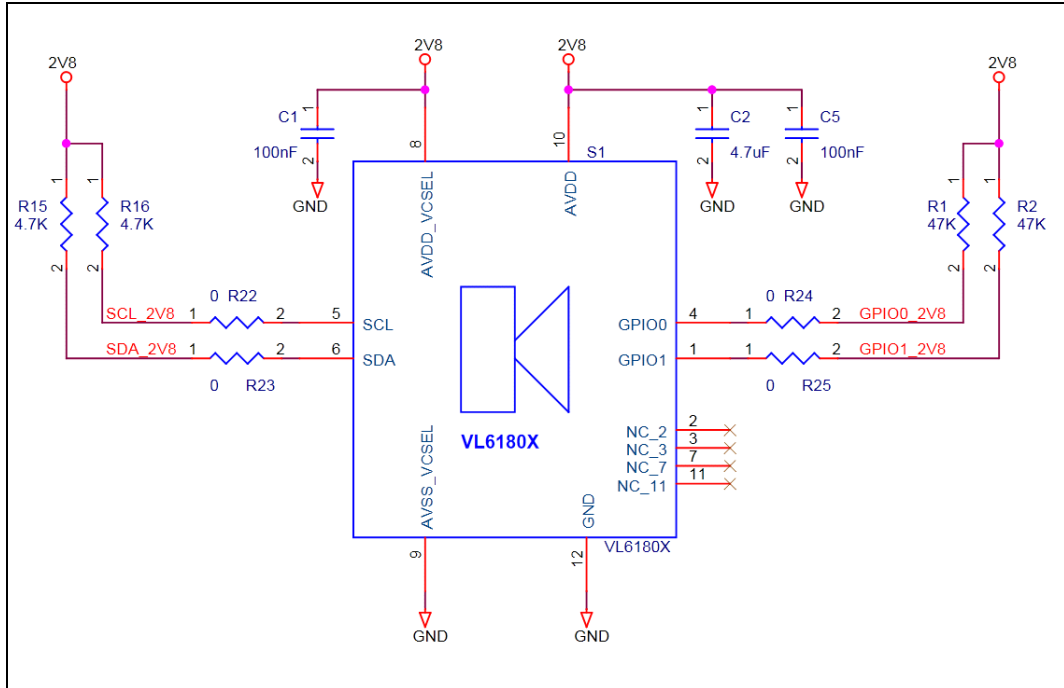
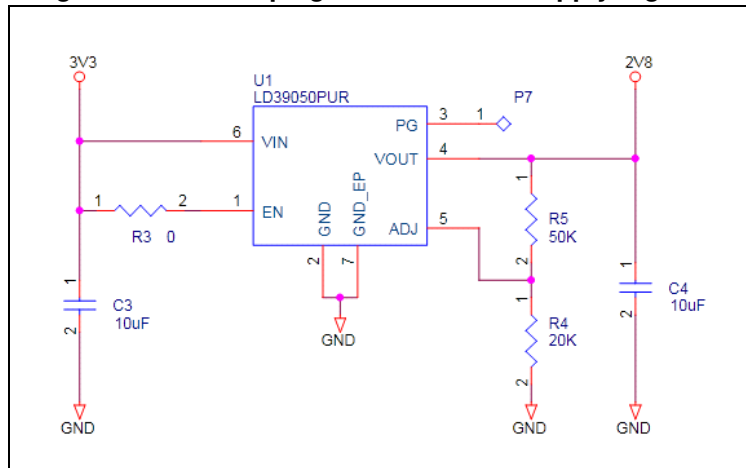

Table 2. List of material - VL6180X application

Reference	Value	Package	Comment
C1, C5	100nF	0603	Ceramic - Decoupling - In a final product, could be in a 0402 package
C2	4.7µF	0603	Ceramic - 6V - Decoupling
R1, R2	47KΩ	0603	Pull up - In a final product, could be in a 0402 package
R15, R16	4.7KΩ	0603	Pull up - In a final product, could be in a 0402 package and used for several devices
S1	VL6180X	Module	Proximity and ambient light sensing (ALS) module

Figure 3. VL6180X plug-in board - 2.8V supply regulator



Note: This regulator is requested to convert the 3.3V coming from the Nucleo or Arduino board to 2.8V. In a final product, if exists, the 2.8V regulator can be used to supply the VL6180X.

Figure 4. VL6180X plug-in board - Level shifter

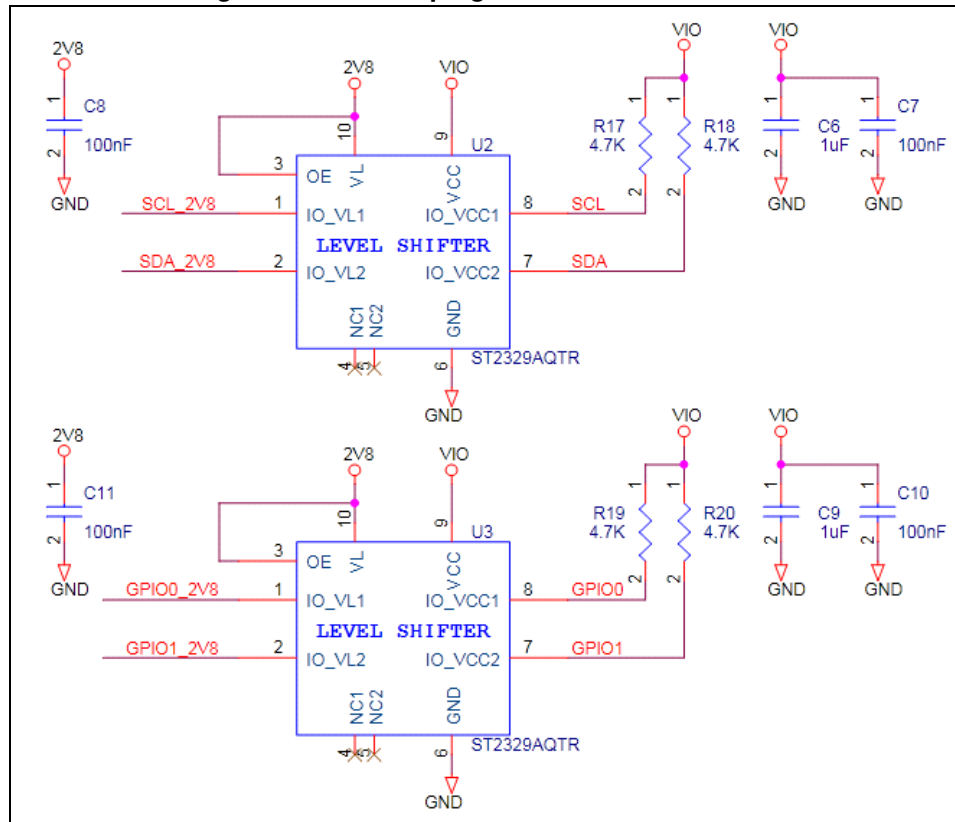

These level shifters are used only to provide the adequate voltage for I/O's and I2C bus, thus allowing to connect a 5V Arduino board without hardware modification. In a final product, depending of the power management tree, they could be omitted.

Figure 5. VL6180X plug-in board - Nucleo_Arduino connector and switch to select value displayed.

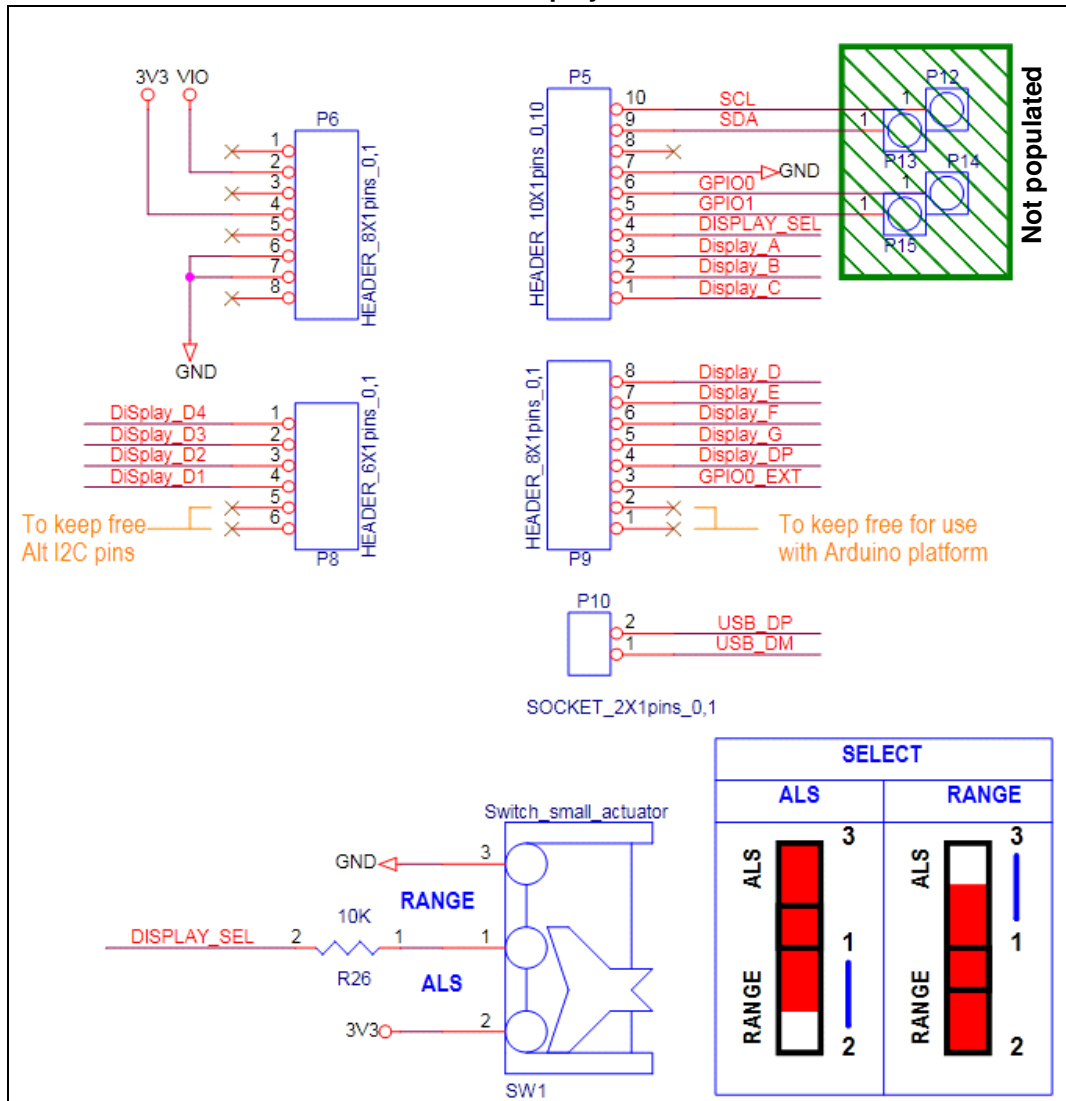

SW1 switch selects if distance or ambient light value is displayed.

- Distance is displayed in mm
- Ambient light is displayed in Lux with a maximum value of 9999.^(d)

d. VL6180X detects up to 100KLux but since the display is 4 digits only, maximum displayed value is limited to 9999 Lux

Table 3. Arduino left connector on NUCLEO-F401RE board

CN Nb	VL6180X board	Pin Nb	Pin name	MCU pin	VL6180X plug-in board function
CN6 Power	-	1	NC	-	-
	VIO	2	IOREF	-	Level shifter reference (3.3V)
	-	3	RESET	NRST	-
	Power	4	+3V3	-	3.3V supply
	-	5	+5V	-	-
	Gnd	6	Gnd	Gnd	Gnd
	Gnd	7	Gnd	Gnd	Gnd
	-	8	VIN	-	-
CN8 Analog	Display_D4	1	A0	PA0	Display control - Digits
	Display_D3	2	A1	PA1	
	Display_D2	3	A2	PA4	
	Display_D1	4	A3	PB0	
	-	5	A4	PC1 or PB9 ⁽¹⁾	-
	-	6	A5	PC1 or PB8 ⁽¹⁾	-

1. Depend on Nucleo board solder bridges, see details on Nucleo documentation

Table 4. Arduino right connector on NUCLEO-F401RE board

CN Nb	VL6180X plug-in board	Pin Nb	Pin name	MCU pin	VL6180X plug-in board function	
CN5 Digital	SCL	10	D15	PB8	I2C1_SCL	
	SDA	9	D14	PB9	I2C1_SDA	
	-	8	AREF	-	-	
	Gnd	7	Gnd	Gnd	Gnd	
	GPIO0	6	D13	PA5	Chip enable	
	GPIO1	5	D12	PA6	Interrupt	
	Display_sel	4	D11	PA7	Switch control to select distance or ambient light value on display	
	Display A	3	D10	PB6	Display control - Segments	
	Display B	2	D9	PC7		
Display C	1	D8	PA9			
Display D	8	D7	PA8			
Display E	7	D6	PB10			
Display F	6	D5	PB4			
CN9 Digital	Display G	5	D4	PB5	Display control - Segments	
	Display DP	4	D3	PB3		
	GPIO0_EXT	3	D2	PA10		Chip enable for a second VL6180X (external to plug-in board)
	-	2	D1	PA2		-
	-	1	D0	PA3	-	

Figure 6. VL6180X plug-in board - External VL6180X connector

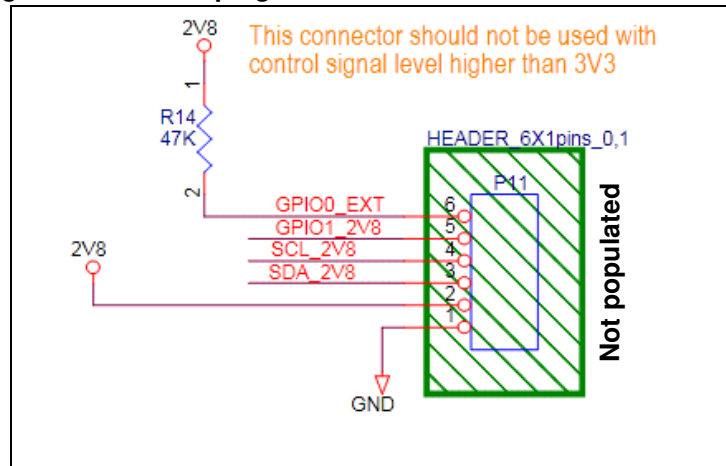

For dual sensor application the second VL6180X application is connected through flying wires soldered in the 6- pin connector (see *Figure 6*). For such application a VL6180X satellite board can be ordered on www.st.com/vl6180x (ordering code: VL6180X-SATEL).

Caution: GPIO0_EXT pin is not connected to a level shifter, please refer to VL6180X datasheet for maximum rating conditions.

Figure 7. VL6180X plug-in board - Display control

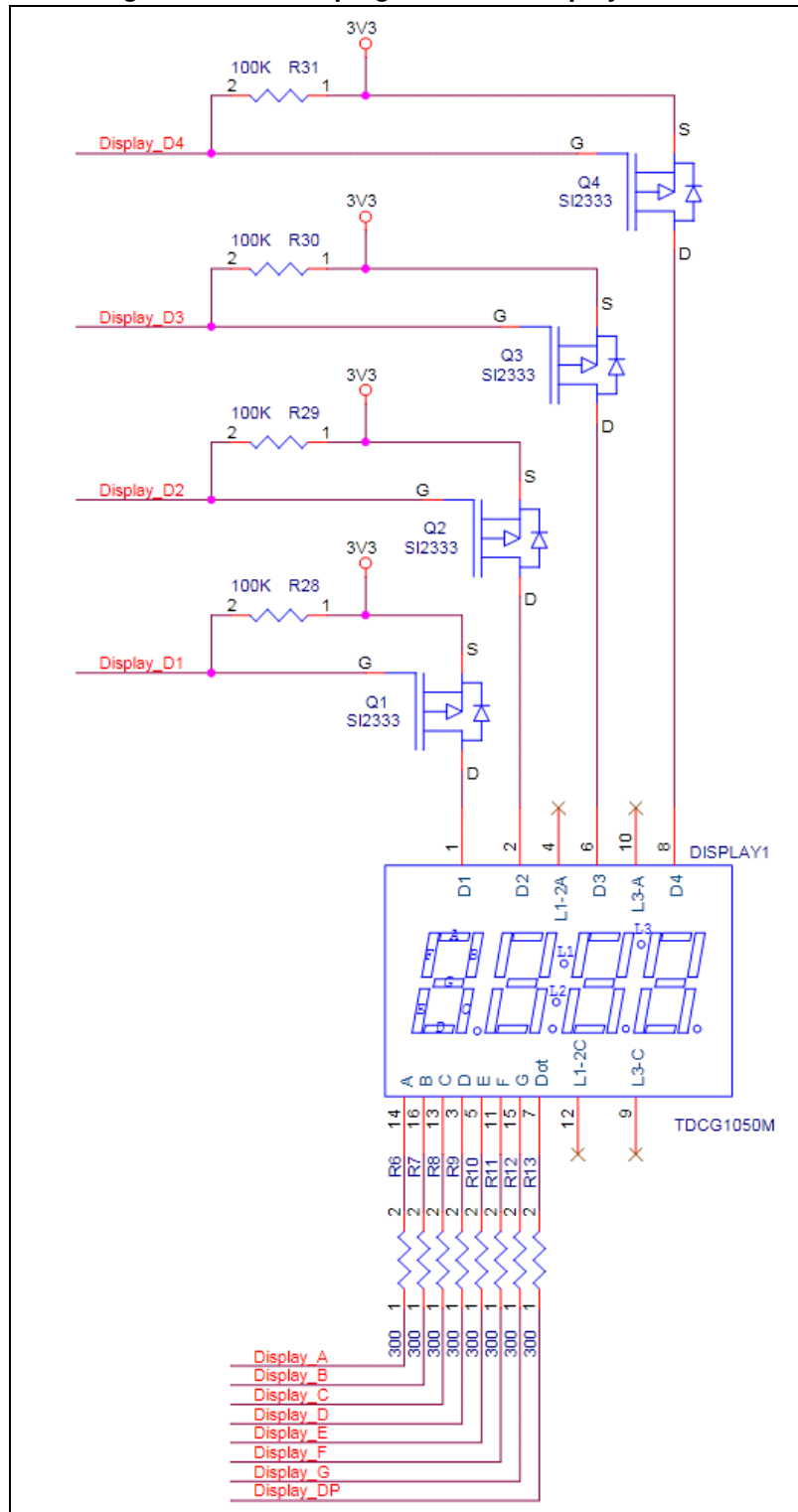

Table 5. List of material - Other features

Reference	Value	Package	Comment
2v8 regulator			
C3, C4	10 μ F	0805	
R4	20 k Ω	0603	
R5	50 k Ω	0603	
U1	LD39050PUR	DFN6	Regulator
Level shifters			
C6, C9	1 μ F	0603	
C7, C8, C10, C11	100 nF	0603	
R17, R18, R19, R20	4.7 k Ω	0603	
U2, U3	ST2329AQTR	QFN10	Level shifter
External VL6180X and Nucleo_Arduino connectors			
R14	47 k Ω	0603	
R26	10 k Ω	0603	
Display control			
R6, R7, R8, R9, R10, R11, R12, R13	300 Ω	0603	
R28, R29, R30, R31	100 k Ω	0603	
Q1, Q2, Q3, Q4	SI2333	SOT23	P channel MOSFET
Display1	TDCG1050M		4 digits

4 Safety

4.1 Electrostatic precaution

Figure 8. Electrostatic logo



You should exercise electrostatic precautions, including using ground straps when using the VL6180X plug-in board. Failure to prevent electrostatic discharge could damage the device.

4.2 Laser considerations

The VL6180X contains a laser emitter and corresponding drive circuitry. The laser output is designed to remain within Class 1 laser safety limits under all reasonably foreseeable conditions including single faults in compliance with IEC 60825-1:2007. The laser output will remain within Class 1 limits as long as the STMicroelectronics recommended device settings are used and the operating conditions specified in the datasheet are respected. The laser output power must not be increased by any means and no optics should be used with the intention of focusing the laser beam.

Figure 9. Class 1 laser product label



Compliance

Complies with 21 CFR 1040.10 and 1040.11 except for deviations pursuant to Laser Notice No.50, dated June 24, 2007.

5 ECOPACK®

In order to meet environmental requirements, ST offers these devices in different grades of ECOPACK® packages, depending on their level of environmental compliance. ECOPACK® specifications, grade definitions and product status are available at: www.st.com. ECOPACK® is an ST trademark.

6 Revision history

Table 6. Document revision history

Date	Revision	Changes
24-Jun-2014	1	Initial release.
18-Aug-2014	2	replace "shield" by "plug-in board"
26-Aug-2014	3	Correction of typo in the document title
26-Jan-2015	4	Add: – Chapter 3: VL6180X plug-in board – Chapter 4: Safety

IMPORTANT NOTICE – PLEASE READ CAREFULLY

STMicroelectronics NV and its subsidiaries ("ST") reserve the right to make changes, corrections, enhancements, modifications, and improvements to ST products and/or to this document at any time without notice. Purchasers should obtain the latest relevant information on ST products before placing orders. ST products are sold pursuant to ST's terms and conditions of sale in place at the time of order acknowledgement.

Purchasers are solely responsible for the choice, selection, and use of ST products and ST assumes no liability for application assistance or the design of Purchasers' products.

No license, express or implied, to any intellectual property right is granted by ST herein.

Resale of ST products with provisions different from the information set forth herein shall void any warranty granted by ST for such product.

ST and the ST logo are trademarks of ST. All other product or service names are the property of their respective owners.

Information in this document supersedes and replaces information previously supplied in any prior versions of this document.

© 2015 STMicroelectronics – All rights reserved