

TRF2436EVM

This user's guide provides an overview of the TRF2436 evaluation module (EVM) to get you started using the TRF2436EVM right away. It also provides a general description of the features and functions to be considered when using this module.

Contents

1	Introduction	1
2	TRF2436EVM Operational Procedure	2
3	Physical Description	3

List of Figures

1	Top Layer 1.....	4
2	Ground Plane Layer 2.....	4
3	Power Plane Layer 3.....	5
4	Bottom Layer 4.....	5

List of Tables

1	TRF2436EVM PARTS LIST.....	6
---	----------------------------	---

1 Introduction

1.1 Purpose

The TRF2436 EVM provides a platform for evaluating the TRF2436 high-power, dual-band RF front-end under various signals, reference, and supply conditions. Use this document with the EVM schematic diagram supplied. Using the TRF2436EVM, you can rapidly evaluate the TRF2436 with a minimum of manual setup.

1.2 System Requirements

Use the following equipment when evaluating the TRF2436EVM:

- +3.3-V power supply, 800 mA.
- Signal generator: Agilent ESG Series (with baseband I/Q modulation option for modulated testing) or equivalent.
- Spectrum analyzer: Agilent PSA Series (with phase noise option) or equivalent.
- Vector signal analyzer: Agilent 89600 Series for 802.16x modulated EVM testing or equivalent.

1.3 Power Requirements

The demonstration board requires only one supply for proper operation. Connect +3.3 V at P1 and the return to P2. Always terminate active PA outputs before enabling the power supply.

Voltage Limits

Exceeding the maximum input voltages can damage EVM components. Undervoltage can cause improper operation of some or all of the EVM components.

1.4 Hardware Configuration

The TRF2436EVM can be set up in a variety of configurations to accommodate a specific mode of operation. Before starting an evaluation, decide on the configuration and make the appropriate connections or changes. The demonstration board comes with the following factory-set configuration:

- Jumper J10 installed between 1-2
- Jumper J11 installed between 2-3
- Jumper J12 installed between 1-2
- Jumper J13 installed between 1-2
- Jumper J14 installed between 1-2

LO input drive

The TRF2436 has been designed to be driven with a differential LO input. A simple balun centered at ~2.6 GHz can be used to convert a single-ended input from an RF source to a differential pair to provide a differential LO to the EVM through SMA connectors J3 and J4.

The 2436 will function if driven single-ended, but it is not designed to operate in this condition, nor has it been evaluated in this condition. To drive the LO single-ended, connect an RF source to the LOP SMA (J3) and terminate the LON SMA (J4) input with 50 Ω .

Filtering

The TRF2436EVM is provided with no filtering. The mixer output, PA input/LNA output, and RF input/output pins are brought out directly to SMA connectors on the EVM. Filtering may be incorporated by:

- Connecting an external filter to RFANTA (J6) for filtering after the PA in TX mode or before the LNA in RX mode.
- Connecting an external filter between the MFA (J8) and RFA (J9) jacks for filtering between the mixer and PA/LNA stages

2 TRF2436EVM Operational Procedure

2.1 TX Operation

1. Connect +3.3 V to P1 and ground to P2 but do not turn on.
2. Connect differential LO source to LOP/LON jacks (or use external balun).
Set the appropriate frequency and power level between 0 to +4 dBm. Remember that for A-band operation, the LO input frequency is doubled inside the TRF2436; so, the LO should be set to half the frequency desired at the mixer LO port.
3. Connect an IF source to the IF port. Set to 374 MHz with a typical power level of -20 dBm.
4. Set ABSEL (J12) to a logic high 1.
5. Set TR (J13) to a logic high 1.
6. Set PA_B SEL (J11) to a logic low 0.
7. Set PA_A SEL (J10) to logic high 1.
8. RXDGC = don't care
9. For mixer stage measurement:
 - a. Terminate RFA (J9) and RFANTA (J6) into 50 Ω .
 - b. Connect a spectrum analyzer to MFA (J8).
 - c. Turn on the 3.3-V power supply (~300 mA to 320 mA).
 - d. Observe the output of the mixer stage on a spectrum analyzer.
10. For PA stage measurement:
 - a. Terminate IF (J7) and MFA (J8) into 50 Ω .
 - b. Apply an RF to RFA (J9).
 - c. Connect a spectrum analyzer to RFANTA (J6).
 - d. Turn on the power supply.
 - e. Observe the PA output on a spectrum analyzer.

2.2 RX Operation

1. Set TR (J13) to logic 0.
2. Set PA_A SEL (J10) to logic 0.
3. Connect a differential LO source to the LOP/LON SMAs (or use an external balun). Set the LO to an appropriate frequency, with the power level between 0 to +4 dBm. Remember that for A-band operation, the LO input frequency is doubled inside the TRF2436; so, the LO should be set to half the frequency desired at the mixer LO port.
4. For mixer stage measurement:
 - a. Terminate RFA (J9) and RFANTA (J6) into 50 Ω .
 - b. Connect an RF source to MFA (J8). Set to a desired RF frequency and typical power level of -20 dBm.
 - c. Connect a spectrum analyzer to the IF (J7) output.
 - d. Turn on the 3.3-V power supply (~90 mA).
 - e. Observe the IF output on a spectrum analyzer (374 MHz).
5. For LNA stage measurement:
 - a. Terminate IF (J7) and MFA (J8) into 50 Ω .
 - b. Connect an RF source to RFANTA (J6). Set to a desired frequency and typical power level of -40 dBm.
 - c. Connect a spectrum analyzer to RFA (J9).
 - d. Turn on the power supply.
 - e. Observe the LNA output on a spectrum analyzer.
 - f. Use jumper J14 (RXDGC) to select between LNA high (pins 2-3) and low gain (pins 1-2) modes.

3 Physical Description

This section describes the physical characteristics and PCB layout of the EVM and lists the components used on the module.

3.1 PCB Layout

The EVM is constructed on a 4-layer, 3.6-inch × 3.6-inch, 0.042-inch thick PCB using Polycad 370 Turbo/HR material. Figure 1 through Figure 4 show the PCB layout for the EVM.

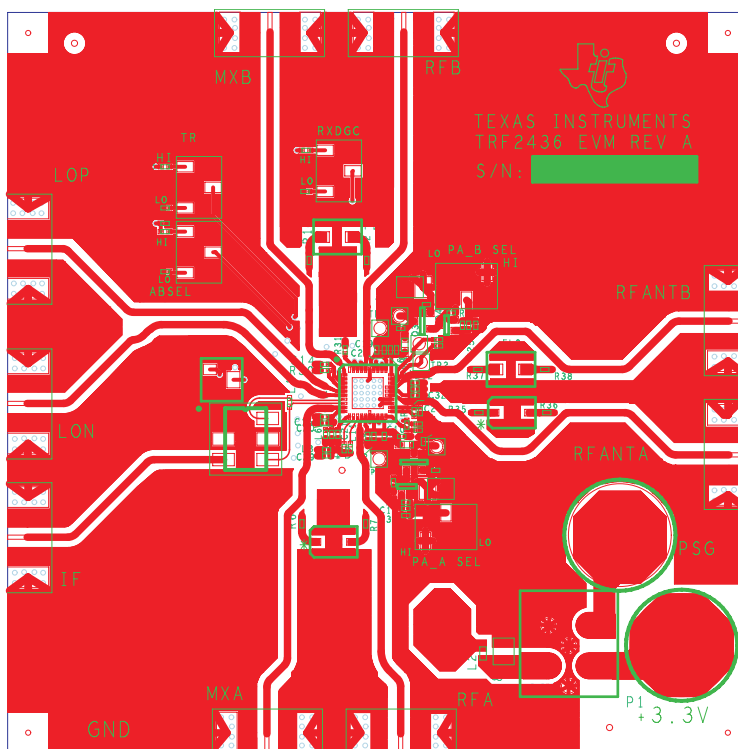

Figure 1. Top Layer 1

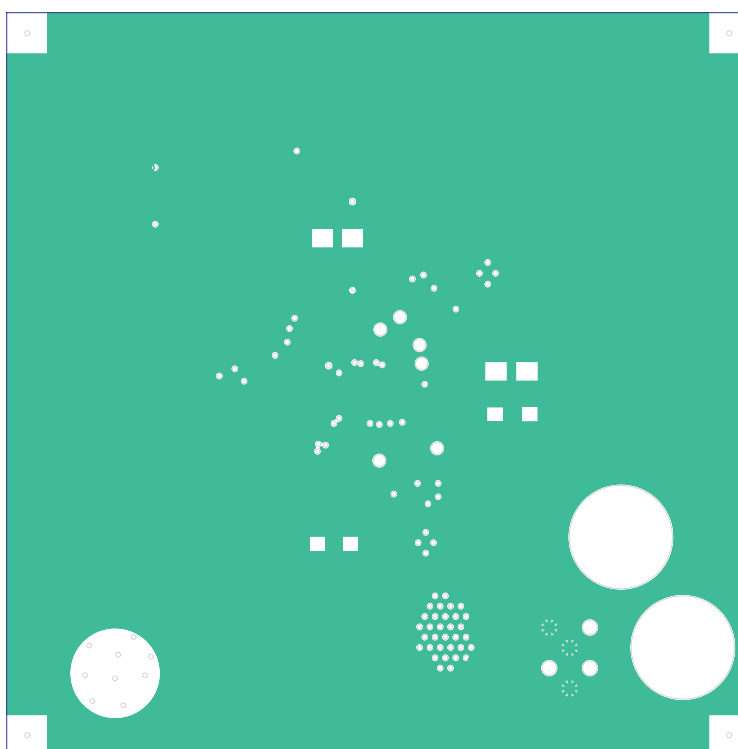

Figure 2. Ground Plane Layer 2

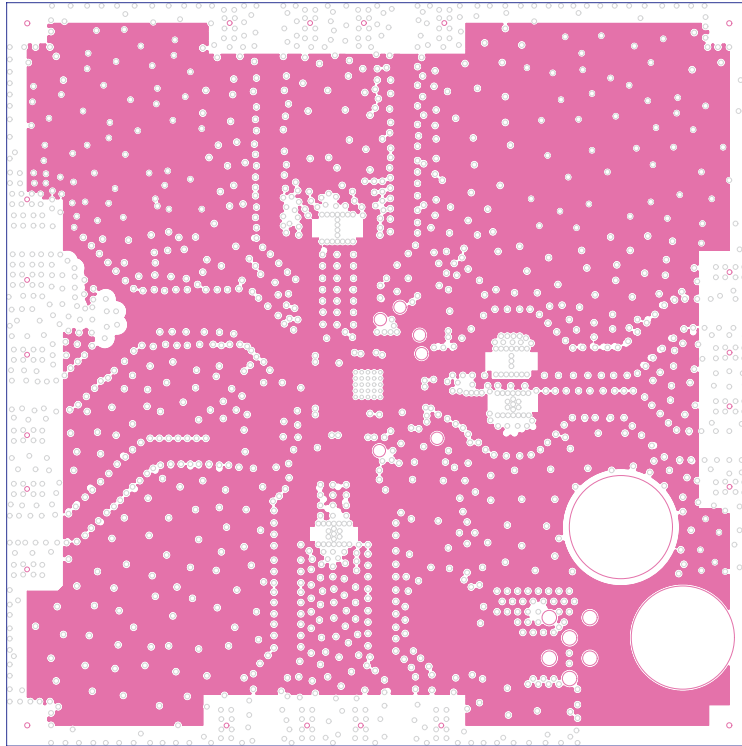

Figure 3. Power Plane Layer 3

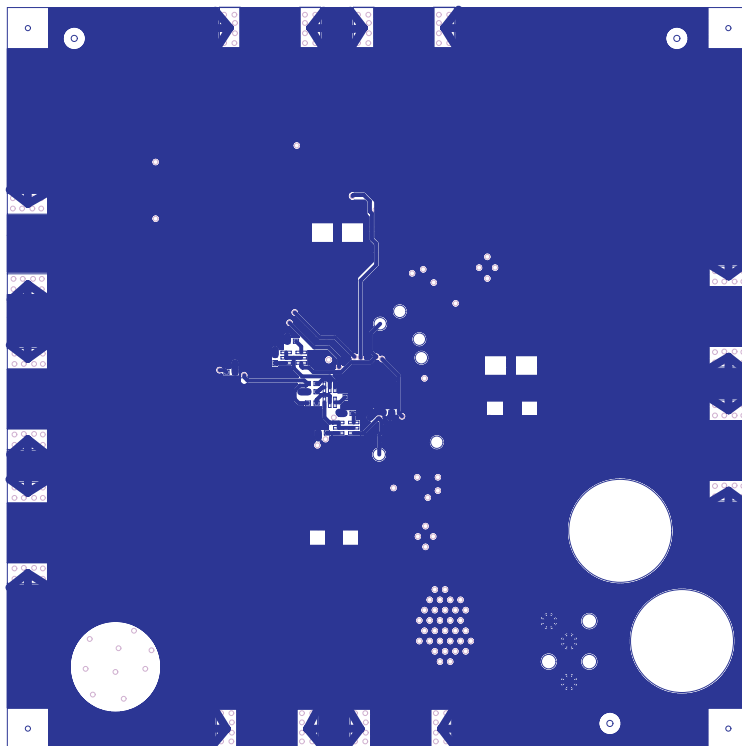

Figure 4. Bottom Layer 4

Physical Description

3.2 Part List

Table 1 lists the parts used in constructing the EVM.

Table 1. TRF2436EVM PARTS LIST

QTY	Ref	Value	Part Number	Note
1	C1	470pF	GRM033R71C471KD	
1	C2	10pF	GRM1555C1H100JZ	
1	C3	5600pF	C0402C562K3RACT	
7	C4 C6 C11 C15 C17 C24 C33	0.01 μ F	GRM155R71E103KA	
12	C5 C9 C12–C14 C16 C19 C20 C22 C25 C26 C31	100pF	GRM1555C1H101JD	
3	C7 C8 C18	10 μ F	ECJ-4YB1A106K	
3	C10 C23 C29	1000pF	GRM155R71H102KA	
2	C21 C32	1.2pF	04025A1R2BAT2A	
1	C28	0.1 μ F	ECJ-0EB1A104K	
2	FL1 FL2	Filter, 2400–2484MHz	DFCB22G44LBJAA	DNI
2	FL3 FL4	Filter, 5597.5MHz	DFCB35G59LAHAA	DNI
1	FL5	Filter Block, DC power	BNX002-01	
9	J1–J9	MXB SMA	142-0701-841	
5	J10–J14	PA_A SEL	54201-S08-3	
4	L1 R3 R4 R31			DNI
3	L2 L3 L7	27 Ω at 100MHz	EXC-ML16A270U	
4	L6 L8 L10 L12	120 Ω at 100MHz	BLM15AG102SN1D	
2	L9 L11	33nH	LQW15AN33NJ00D	
1	P1	+3.3V_IN	ST-351A	
1	P2	PSG	ST-351B	
2	Q1 Q3	IRLML6401	IRLML6401	
2	Q2 Q4	MMST2222A	MMST2222A-7	
8	R1 R2 R6 R7 R35–R38	TRACE GAP, NO PART		DNI
1	R5	634	ERJ-2RKF6340X	
9	R8–R13 R15 R32 R33	10K	ERJ-2GEJ103X	
7	R16–R18 R24 R25 R28 R29	1K	ERJ-2GEJ102X	
4	R20–R23	200	ERJ-2RKF2000X	
1	R26	750	ERJ-2GEJ751X	
1	R27	2K POT	3214W-1-202E	
1	R30	5.1K	ERJ-2GEJ512X	
1	T1	ADT4-1T	ADT4-1T	
6	TP1–TP6	T POINT R	5015	
1	U1	TRF2436	TRF2436	
2	U2 U3	MMDT3906	MMDT3906-7	
1	U4	MMDT3904	MMDT3904-7	

3.3 Schematic Drawing

The schematic drawing for the TRF2436EVM appears on the following page.

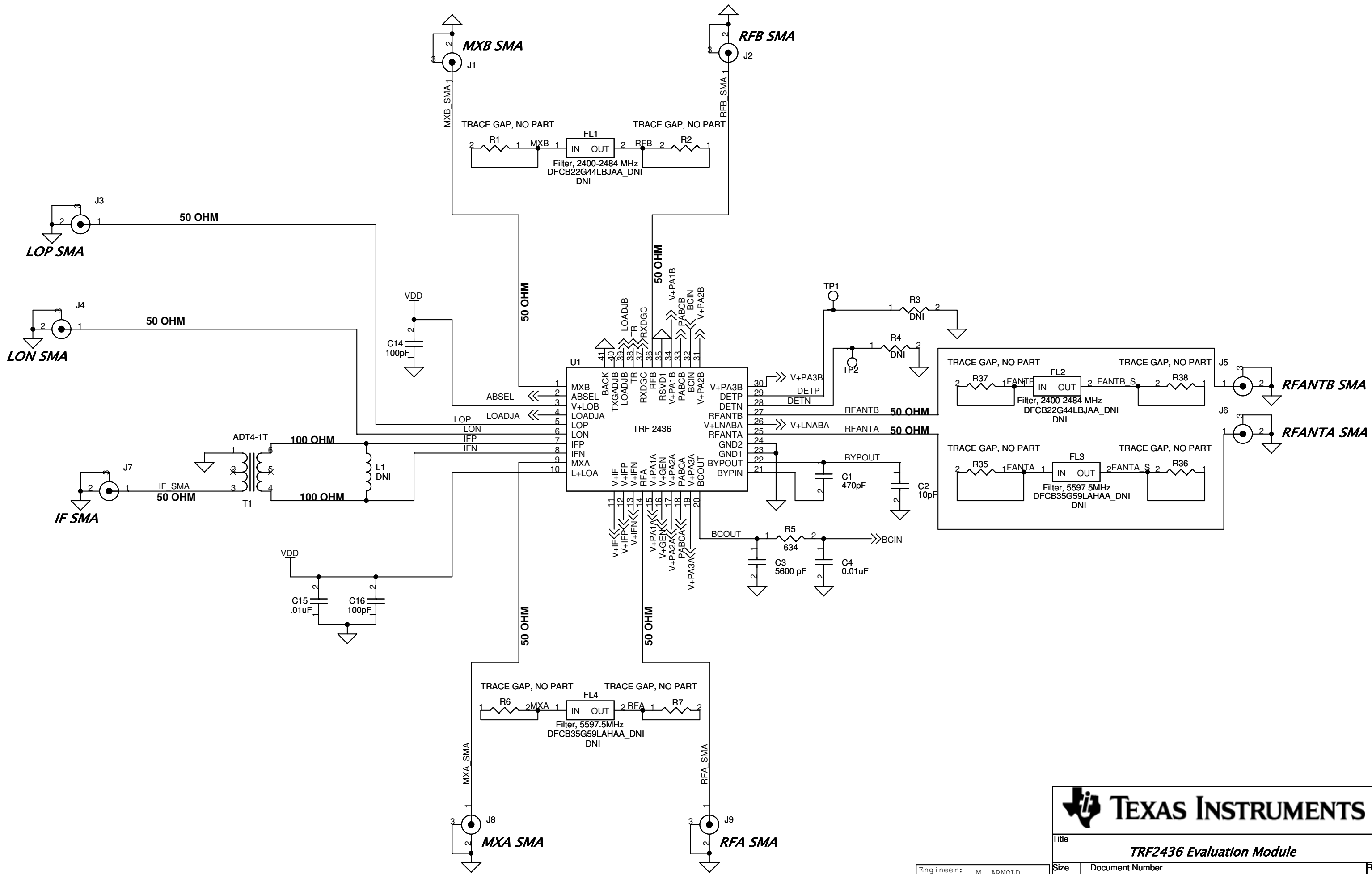

TEXAS INSTRUMENTS

Title: **TRF2436 Evaluation Module**

Size B	Document Number TRF2436EVM-SCH	Rev A
Date: Monday, April 17, 2006	Sheet 1 of 3	

Engineer: M. ARNOLD
 Drawn By: L. NGUYEN

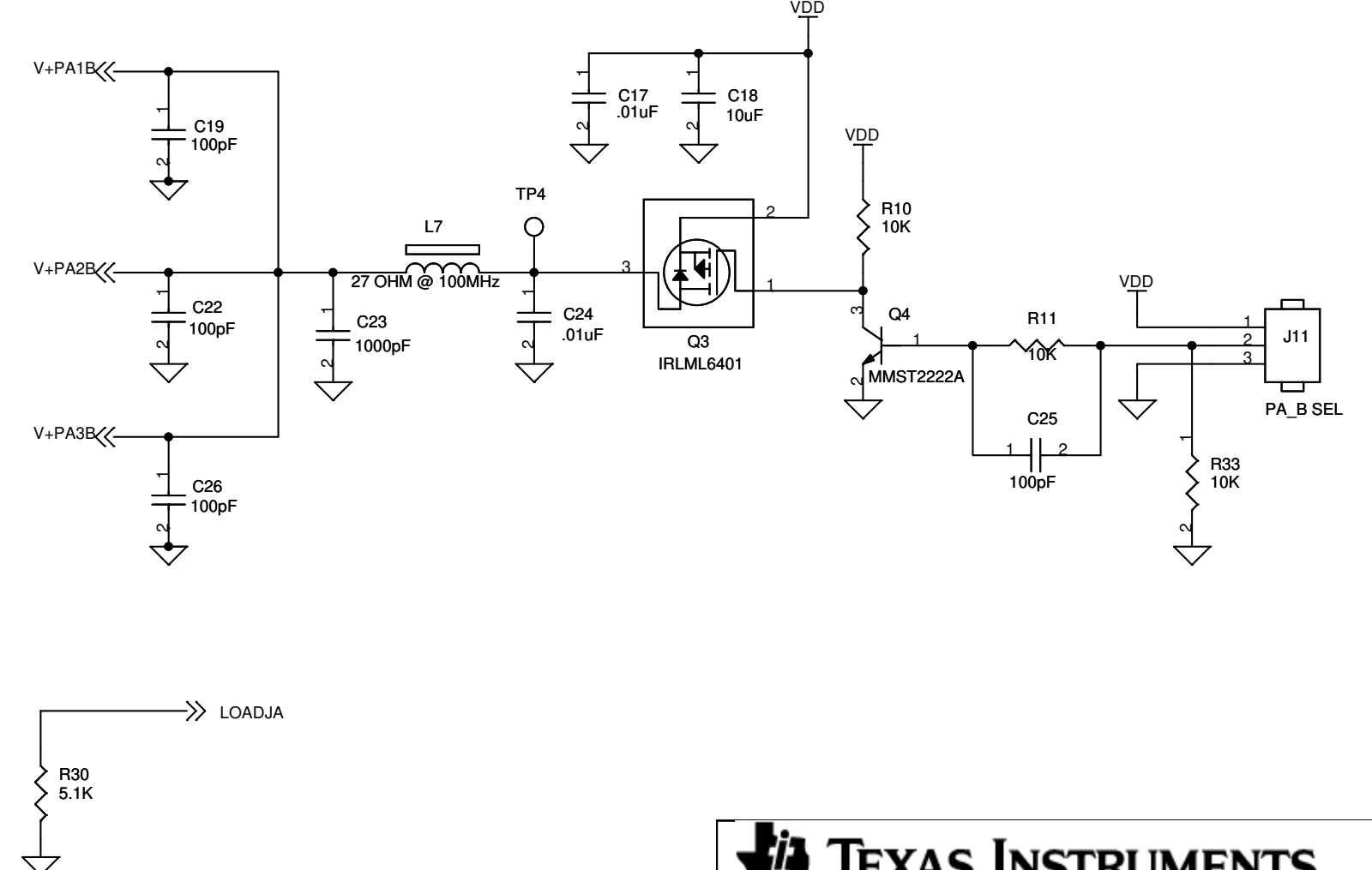
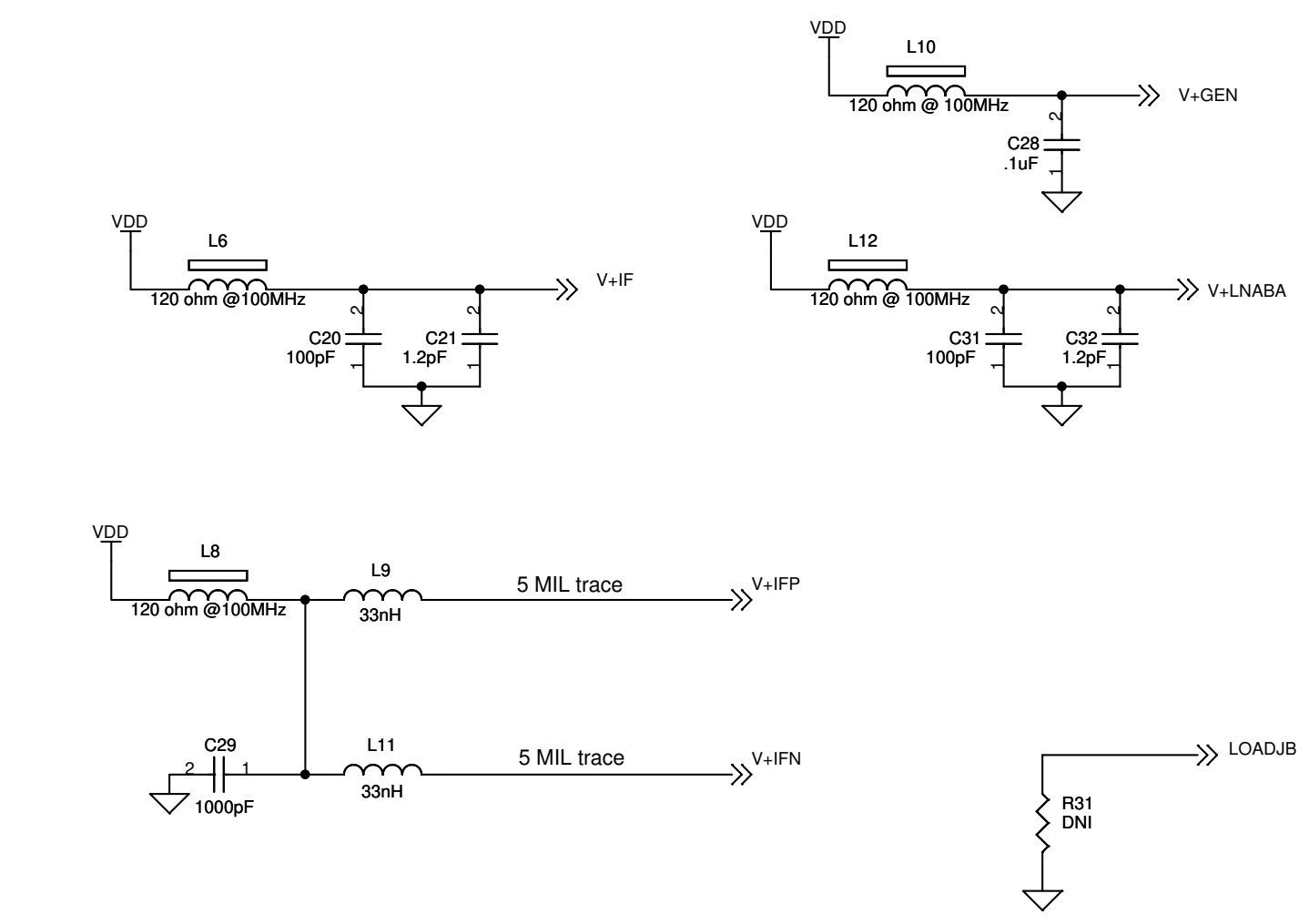
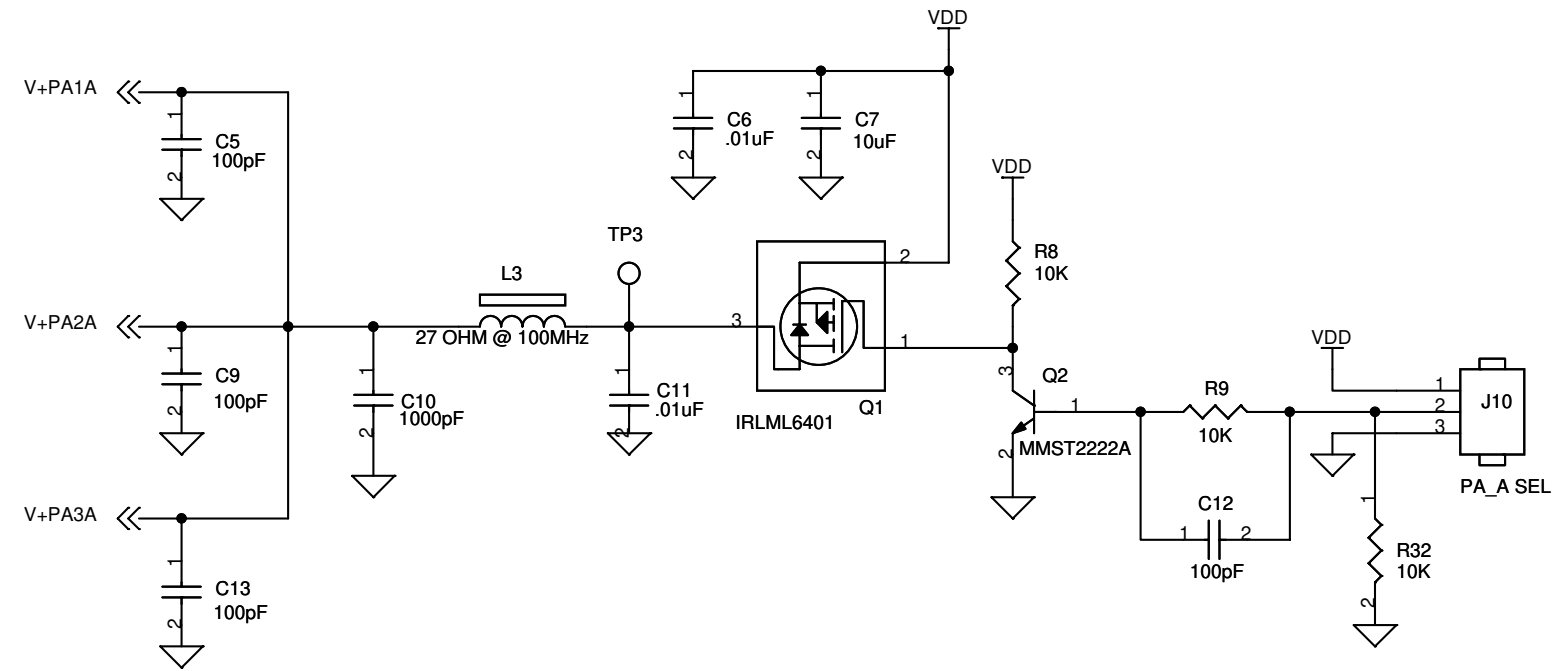
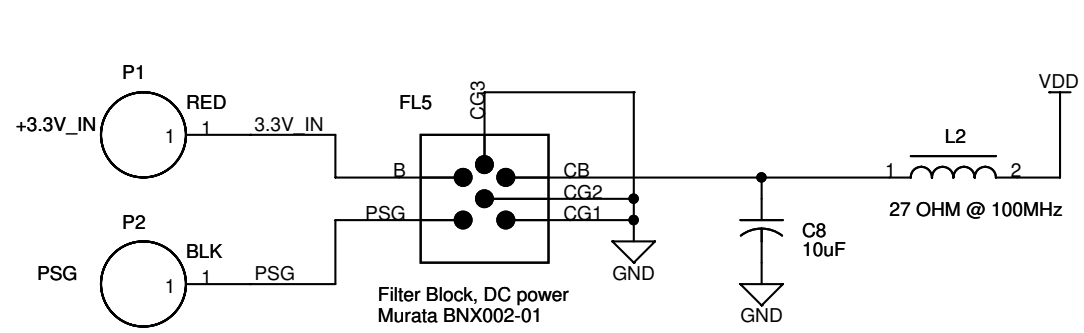

TEXAS INSTRUMENTS

Title: **TRF2436 Evaluation Module**

Size: B	Document Number: TRF2436EVM-SCH	Rev: A
Date: Thursday, April 13, 2006	Sheet: 2 of 3	

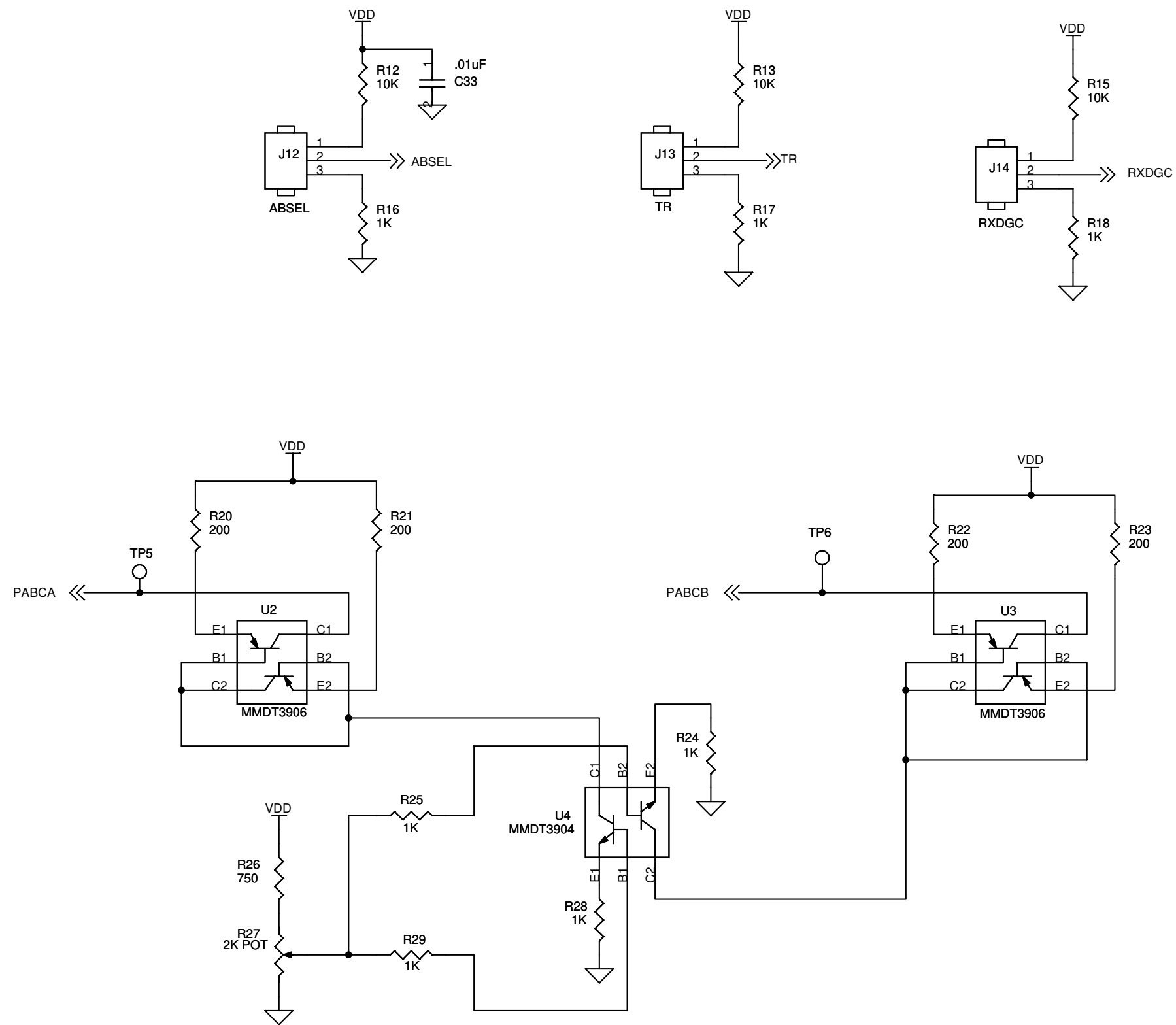

Title		
TRF2436 Evaluation Module		
Size	Document Number	Rev
B	TRF2436EVM-SCH	A
Date:	Thursday, April 13, 2006	Sheet 3 of 3

EVALUATION BOARD/KIT IMPORTANT NOTICE

Texas Instruments (TI) provides the enclosed product(s) under the following conditions:

This evaluation board/kit is intended for use for **ENGINEERING DEVELOPMENT, DEMONSTRATION, OR EVALUATION PURPOSES ONLY** and is not considered by TI to be a finished end-product fit for general consumer use. Persons handling the product(s) must have electronics training and observe good engineering practice standards. As such, the goods being provided are not intended to be complete in terms of required design-, marketing-, and/or manufacturing-related protective considerations, including product safety and environmental measures typically found in end products that incorporate such semiconductor components or circuit boards. This evaluation board/kit does not fall within the scope of the European Union directives regarding electromagnetic compatibility, restricted substances (RoHS), recycling (WEEE), FCC, CE or UL, and therefore may not meet the technical requirements of these directives or other related directives.

Should this evaluation board/kit not meet the specifications indicated in the User's Guide, the board/kit may be returned within 30 days from the date of delivery for a full refund. **THE FOREGOING WARRANTY IS THE EXCLUSIVE WARRANTY MADE BY SELLER TO BUYER AND IS IN LIEU OF ALL OTHER WARRANTIES, EXPRESSED, IMPLIED, OR STATUTORY, INCLUDING ANY WARRANTY OF MERCHANTABILITY OR FITNESS FOR ANY PARTICULAR PURPOSE.**

The user assumes all responsibility and liability for proper and safe handling of the goods. Further, the user indemnifies TI from all claims arising from the handling or use of the goods. Due to the open construction of the product, it is the user's responsibility to take any and all appropriate precautions with regard to electrostatic discharge.

EXCEPT TO THE EXTENT OF THE INDEMNITY SET FORTH ABOVE, NEITHER PARTY SHALL BE LIABLE TO THE OTHER FOR ANY INDIRECT, SPECIAL, INCIDENTAL, OR CONSEQUENTIAL DAMAGES.

TI currently deals with a variety of customers for products, and therefore our arrangement with the user **is not exclusive.**

TI assumes **no liability for applications assistance, customer product design, software performance, or infringement of patents or services described herein.**

Please read the User's Guide and, specifically, the Warnings and Restrictions notice in the User's Guide prior to handling the product. This notice contains important safety information about temperatures and voltages. For additional information on TI's environmental and/or safety programs, please contact the TI application engineer or visit www.ti.com/esh.

No license is granted under any patent right or other intellectual property right of TI covering or relating to any machine, process, or combination in which such TI products or services might be or are used.

FCC Warning

This evaluation board/kit is intended for use for **ENGINEERING DEVELOPMENT, DEMONSTRATION, OR EVALUATION PURPOSES ONLY** and is not considered by TI to be a finished end-product fit for general consumer use. It generates, uses, and can radiate radio frequency energy and has not been tested for compliance with the limits of computing devices pursuant to part 15 of FCC rules, which are designed to provide reasonable protection against radio frequency interference. Operation of this equipment in other environments may cause interference with radio communications, in which case the user at his own expense will be required to take whatever measures may be required to correct this interference.

EVM WARNINGS AND RESTRICTIONS

It is important to operate this EVM within the input voltage range of 0 V to 3.3 V and the output voltage range of 0 V to 3.3 V.

Exceeding the specified input range may cause unexpected operation and/or irreversible damage to the EVM. If there are questions concerning the input range, please contact a TI field representative prior to connecting the input power.

Applying loads outside of the specified output range may result in unintended operation and/or possible permanent damage to the EVM. Please consult the EVM User's Guide prior to connecting any load to the EVM output. If there is uncertainty as to the load specification, please contact a TI field representative.

During normal operation, some circuit components may have case temperatures greater than 85°C. The EVM is designed to operate properly with certain components above 85°C as long as the input and output ranges are maintained. These components include but are not limited to linear regulators, switching transistors, pass transistors, and current sense resistors. These types of devices can be identified using the EVM schematic located in the EVM User's Guide. When placing measurement probes near these devices during operation, please be aware that these devices may be very warm to the touch.

Mailing Address: Texas Instruments, Post Office Box 655303, Dallas, Texas 75265
Copyright © 2006, Texas Instruments Incorporated

IMPORTANT NOTICE

Texas Instruments Incorporated and its subsidiaries (TI) reserve the right to make corrections, modifications, enhancements, improvements, and other changes to its products and services at any time and to discontinue any product or service without notice. Customers should obtain the latest relevant information before placing orders and should verify that such information is current and complete. All products are sold subject to TI's terms and conditions of sale supplied at the time of order acknowledgment.

TI warrants performance of its hardware products to the specifications applicable at the time of sale in accordance with TI's standard warranty. Testing and other quality control techniques are used to the extent TI deems necessary to support this warranty. Except where mandated by government requirements, testing of all parameters of each product is not necessarily performed.

TI assumes no liability for applications assistance or customer product design. Customers are responsible for their products and applications using TI components. To minimize the risks associated with customer products and applications, customers should provide adequate design and operating safeguards.

TI does not warrant or represent that any license, either express or implied, is granted under any TI patent right, copyright, mask work right, or other TI intellectual property right relating to any combination, machine, or process in which TI products or services are used. Information published by TI regarding third-party products or services does not constitute a license from TI to use such products or services or a warranty or endorsement thereof. Use of such information may require a license from a third party under the patents or other intellectual property of the third party, or a license from TI under the patents or other intellectual property of TI.

Reproduction of information in TI data books or data sheets is permissible only if reproduction is without alteration and is accompanied by all associated warranties, conditions, limitations, and notices. Reproduction of this information with alteration is an unfair and deceptive business practice. TI is not responsible or liable for such altered documentation.

Resale of TI products or services with statements different from or beyond the parameters stated by TI for that product or service voids all express and any implied warranties for the associated TI product or service and is an unfair and deceptive business practice. TI is not responsible or liable for any such statements.

TI products are not authorized for use in safety-critical applications (such as life support) where a failure of the TI product would reasonably be expected to cause severe personal injury or death, unless officers of the parties have executed an agreement specifically governing such use. Buyers represent that they have all necessary expertise in the safety and regulatory ramifications of their applications, and acknowledge and agree that they are solely responsible for all legal, regulatory and safety-related requirements concerning their products and any use of TI products in such safety-critical applications, notwithstanding any applications-related information or support that may be provided by TI. Further, Buyers must fully indemnify TI and its representatives against any damages arising out of the use of TI products in such safety-critical applications.

TI products are neither designed nor intended for use in military/aerospace applications or environments unless the TI products are specifically designated by TI as military-grade or "enhanced plastic." Only products designated by TI as military-grade meet military specifications. Buyers acknowledge and agree that any such use of TI products which TI has not designated as military-grade is solely at the Buyer's risk, and that they are solely responsible for compliance with all legal and regulatory requirements in connection with such use.

TI products are neither designed nor intended for use in automotive applications or environments unless the specific TI products are designated by TI as compliant with ISO/TS 16949 requirements. Buyers acknowledge and agree that, if they use any non-designated products in automotive applications, TI will not be responsible for any failure to meet such requirements.

Following are URLs where you can obtain information on other Texas Instruments products and application solutions:

Products		Applications	
Amplifiers	amplifier.ti.com	Audio	www.ti.com/audio
Data Converters	dataconverter.ti.com	Automotive	www.ti.com/automotive
DSP	dsp.ti.com	Broadband	www.ti.com/broadband
Interface	interface.ti.com	Digital Control	www.ti.com/digitalcontrol
Logic	logic.ti.com	Military	www.ti.com/military
Power Mgmt	power.ti.com	Optical Networking	www.ti.com/opticalnetwork
Microcontrollers	microcontroller.ti.com	Security	www.ti.com/security
RFID	www.ti-rfid.com	Telephony	www.ti.com/telephony
Low Power Wireless	www.ti.com/lpw	Video & Imaging	www.ti.com/video
		Wireless	www.ti.com/wireless

Mailing Address: Texas Instruments, Post Office Box 655303, Dallas, Texas 75265
Copyright © 2007, Texas Instruments Incorporated