

PART NUMBER	REVISION	DESCRIPTION	FEED TYPE
2151843-1	D	FINE CRIMP HEIGHT ADJUST	MECHANICAL
2151843-2	D	FINE CRIMP HEIGHT ADJUST	PNEUMATIC
7-2151843-1	D	MECHANICAL AND CRIMP TOOLING KIT	MECHANICAL
7-2151843-2	D	PNEUMATIC AND CRIMP TOOLING KIT	PNEUMATIC
7-2151843-7	B	CRIMP TOOLING KIT	-

ATLANTIC VERSION TERMINATOR INTERFACE ADAPTER



APPLICATOR DATA		
CRIMP	SIZE	TYPE
WIRE	1.57 mm [.062]	F
INSUL	2.03 mm [.080]	O

APPLICATOR INSTRUCTIONS
408-35042

TERMINAL DATA: HIROSE TERMINAL HIROSE CRIMP SPECIFICATION			
TERMINAL NAME: SOCKET			
WIRE STRIP LENGTH	INSULATION DIAMETER RANGE		
2.00-2.50 mm [.079-.098 IN]	Ø1.20-1.90 mm [.047-.075 IN]		
TERMINAL APPLICATION SPECIFICATION	NONE		
TERMINALS APPLIED			
TE TERMINAL	HIROSE TERMINAL	TE TERMINAL	HIROSE TERMINAL
286890-1	DF1B-2022SCFA	286890-2	DF1B-2022SCF

WIRE SIZE	CRIMP HEIGHT mm [INCH]	CRIMP HEIGHT REFERENCE SETTING
20 AWG	0.88+/-0.03 [.035+/- .001]	7.9
22 AWG	0.82+/-0.03 [.032+/- .001]	9.0
24 AWG	0.77+/-0.03 [.030+/- .001]	9.2

- 1 RECOMMENDED SPARE PARTS
- 2 REFER TO SUPPLIED INSTRUCTION SHEET FOR CLEANING, LUBRICATION AND STORAGE OF APPLICATOR.
- 3 APPLY PART NUMBER 2-23419-6 LOCTITE TO THREADS OF ITEM 242.
- 4 CRIMP HEIGHT REFERENCE SETTING WAS THE SETTING USED WHEN THE APPLICATOR WAS QUALIFIED AT THE FACTORY. ADJUSTMENT MAY BE NECESSARY WHEN RUNNING APPLICATOR IN THE FIELD.
- 5. UNLESS SPECIFIED OTHERWISE TORQUE VALUES SHALL BE USED PER DOCUMENT, 101-35000.

***WARNING**
ON INSTALLATION, SET WIRE DISC TO CRIMP HEIGHT REFERENCE SETTING FOR LARGEST WIRE SIZE. CRIMP HEIGHT REFERENCE SETTINGS GREATER THAN THE VALUE SHOWN MAY CAUSE DAMAGE TO THE CRIMP TOOLING. REFER TO THE INSTRUCTION SHEET FOR PROPER SETUP AND ADJUSTMENTS.

ATLANTIC VERSION
Shown on sheets 1 of 4 & 2 of 4
(Pacific version shown on sheets 3 of 4 & 4 of 4)

LOC	DIST	REVISIONS					
		P	LTN	DESCRIPTION	DATE	OWN	APVD
A	66	C		ECR-16-005015	06APR2016	MR	CT
		D		ECR-19-004658	24MAR2019	TB	CT

-	1	1	1	1	2280441-1	INSERT, SHEAR	282
-	1	-	1	-	2119640-1	PUSH ROD, AIR FEED	250
-	1	-	1	-	1803259-1	BUSHING, FLANGED	249
-	1	-	1	-	2119641-1	FEED CAM, AIR FEED	248
-	1	1	1	1	2119082-8	CAM, SNAIL, INSULATION ADJUSTMENT	244
-	1	1	1	1	2079764-1	WASHER, WAVE SPRING, CREST-TO-CREST	243
-	1	1	1	1	2119083-1	RETAINER, INSULATION DIAL	242
-	2	2	2	2	7-18023-7	SCR, SKT HD CAP M3 X 4.0	241
-	-	1	-	1	2119580-1	MECHANICAL FEED ASSEMBLY	239
-	1	-	1	-	2063440-1	AIR FEED MODULE	238
-	1	1	1	1	356885-4	STOP, SHEAR	237
-	2	-	2	-	21045-3	RING, RETAIN, EXTERN, 3/16 CRESCENT	172
-	REF	REF	REF	REF	994970-2	COUNTER, MAGNETIC	164
-	1	-	1	-	240638-1	SPRING, FEED FINGER	163
-	1	-	1	-	3-23627-7	PIN, RETAIN, GRVD, 3/16 X .854	137
-	1	-	1	-	2119799-1	HOLDER, FEED FINGER, AF	136
-	1	1	1	1	2844908-1	SCREW, LOCKING	99
-	1	1	1	1	2844907-1	POST, LOCKING	98
-	1	1	1	1	455888-7	SPACER, CRIMPER	82
-	1	1	1	1	8-240641-8	SPACER	81
-	1	1	1	1	1803607-1	DOCUMENTATION PACKAGE	71
-	1	1	1	1	2119740-1	TAG, IDENTIFICATION	67
-	2	2	2	2	2168078-1	SCREW, DRIVE, RH, RoHS, 2 x .188	66
-	1	1	1	1	2168083-2	SCR, SKT HD CAP, RoHS, M4 X 8.0	60
-	1	1	1	1	5-18022-5	SCR, HEX HD CAP, M4 X 6.0	59
-	1	1	1	1	1338685-1	PAWL, FEED	56
-	4	4	4	4	2168083-3	SCR, SKT HD CAP, RoHS, M4 X 12.0	54
-	2	2	2	2	2168083-8	SCR, SKT HD CAP, RoHS, M4 X 16	53
-	1	2	1	2	18023-9	SCR, SKT HD CAP M4 X 6.0	49
-	-	1	-	1	2119652-1	FEED CAM, PRE FEED	48
-	-	1	-	1	2119653-1	FEED CAM, POST FEED	47
-	1	1	1	1	1803583-9	APPLICATOR BASIC ASSEMBLY, SF	46
-	1	1	1	1	1803515-1	RAM ASSEMBLY, SF ATLANTIC	44
-	1	1	1	1	1803602-1	SCR, BHSC, RoHS (M8 X 25)	41
-	2	2	2	2	2079383-5	SCR, BHSC, RoHS (M4 X 20)	33
-	2	2	2	2	2-2844962-3	SPACER, CYLINDRICAL, STRIP GUIDE	30
-	1	1	1	1	2844992-1	ASSEMBLY, STRIP GUIDE	29
-	1	1	1	1	1-455888-0	SPACER, CRIMPER	28
-	1	1	1	1	1320928-2	STRIP GUIDE	24
-	1	1	1	1	2168083-2	SCR, SKT HD CAP, RoHS, M4 X 8.0	21
-	2	2	2	2	1-18028-2	WASHER, FLAT, REG M4	20
-	1	1	1	1	2119533-1	STRIPPER, SIDE FEED	19
-	1	1	1	1	1-690518-9	HOLD DOWN, TERMINAL	18
-	1	1	1	1	690463-1	FLOATING SHEAR, REAR	17
-	2	2	2	2	1-2168083-1	SCR, SKT HD CAP, RoHS, M3 X 6	16
-	1	1	1	1	1-690464-4	SHEAR PLATE, REAR	15
-	1	1	1	1	2119862-1	SHEAR HOLDER, REAR	14
-	1	1	1	1	2119806-1	INSERT, SHEAR	13
-	2	2	2	2	3-22280-3	SPRING, COMPRESSION	12
-	1	1	1	1	1-356885-4	STOP, SHEAR	11
-	1	1	1	1	2119805-1	SHEAR HOLDER, FRONT	10
-	1	1	1	1	1803095-6	FLOATING SHEAR, FRONT	9
-	1	2	2	1	1803336-5	ANVIL, COMBINATION	8
-	1	1	1	1	1-240641-9	SPACER	7
-	1	1	1	1	690468-1	DEPRESSOR SHEAR, REAR	6
-	1	1	1	1	2119757-4	DEPRESSOR, SHEAR	5
-	1	1	1	1	2-238011-5	BLOCK, CRIMPER SPACER	4
-	1	2	2	1	1803329-1	CRIMPER, INSULATION O PREMIUM	3
-	1	1	1	1	455888-7	SPACER, CRIMPER	2
-	1	2	2	1	1-1803325-1	CRIMPER, WIRE	1

DIMENSIONS:		TOLERANCES UNLESS OTHERWISE SPECIFIED:		MATERIAL:		FINISH:	
mm	0 PLC ±	1 PLC ±	2 PLC ±	3 PLC ±	4 PLC ±	ANGLES ±	FINISH ±

OWN	CHK	DATE	NAME
J. STAKEM	G. BAILEY	28DEC2012	J. ELBIN
APVD		DATE	PRODUCT SPEC
APVD		DATE	APPLICATION SPEC
SIZE	CAGE CODE	DRAWING NO	RESTRICTED TO
A1	00779	2151843	-
Customer Accessible Production Drawing			SCALE 1:1 SHEET 1 OF 4 REV D

LOC	DIST	REVISIONS					
A	66	P	LYN	DESCRIPTION	DATE	DWN	APVD
		-	-	SEE SHEET 1	-	-	-

FEED TYPE MECHANICAL

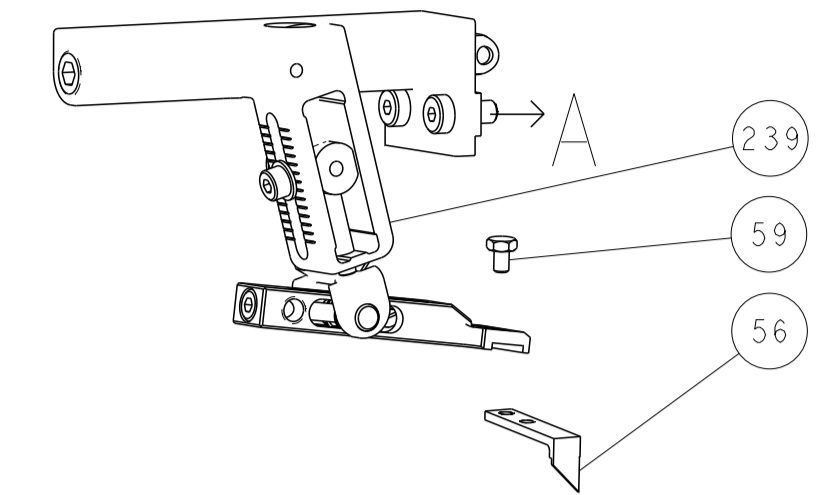

PNEUMATIC

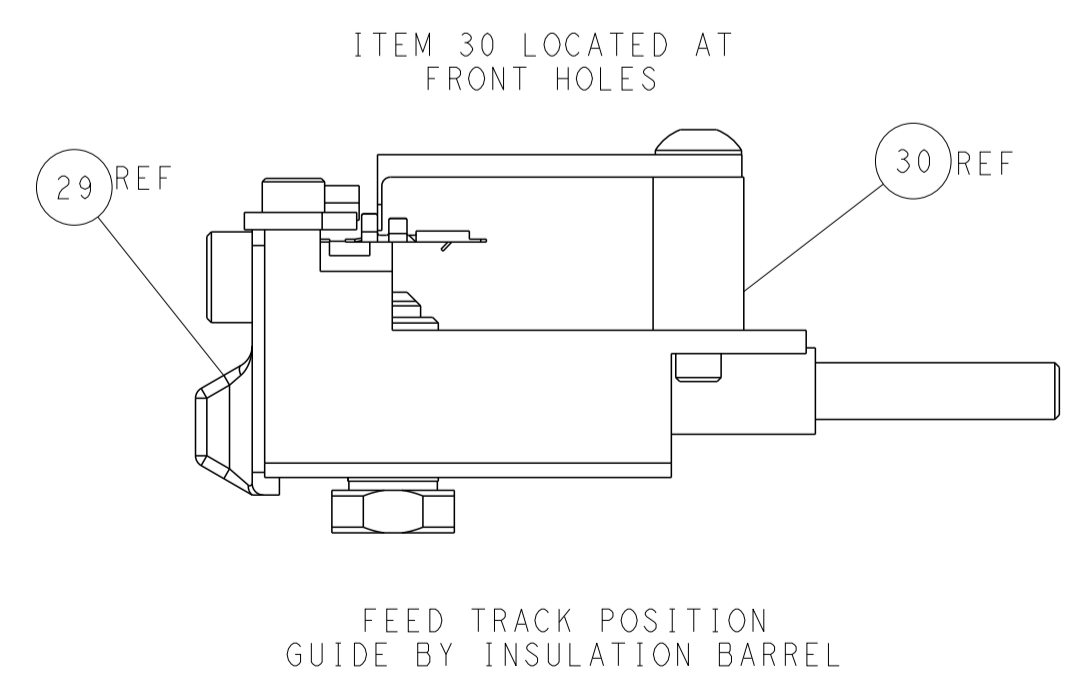
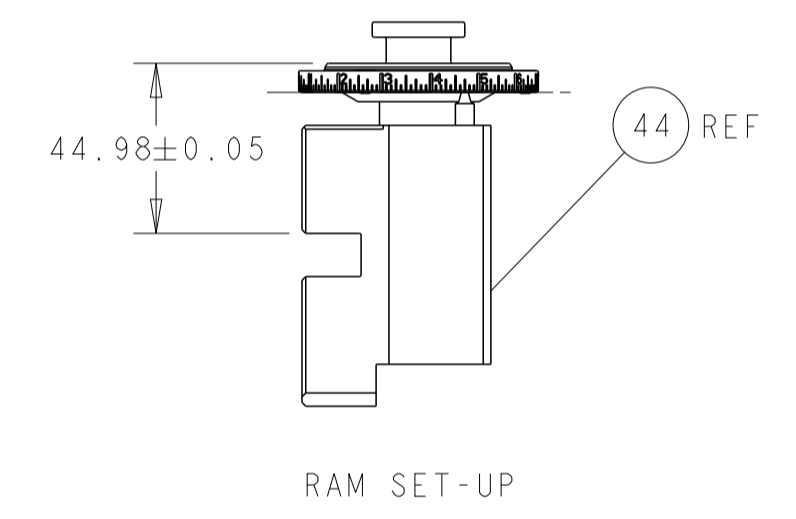
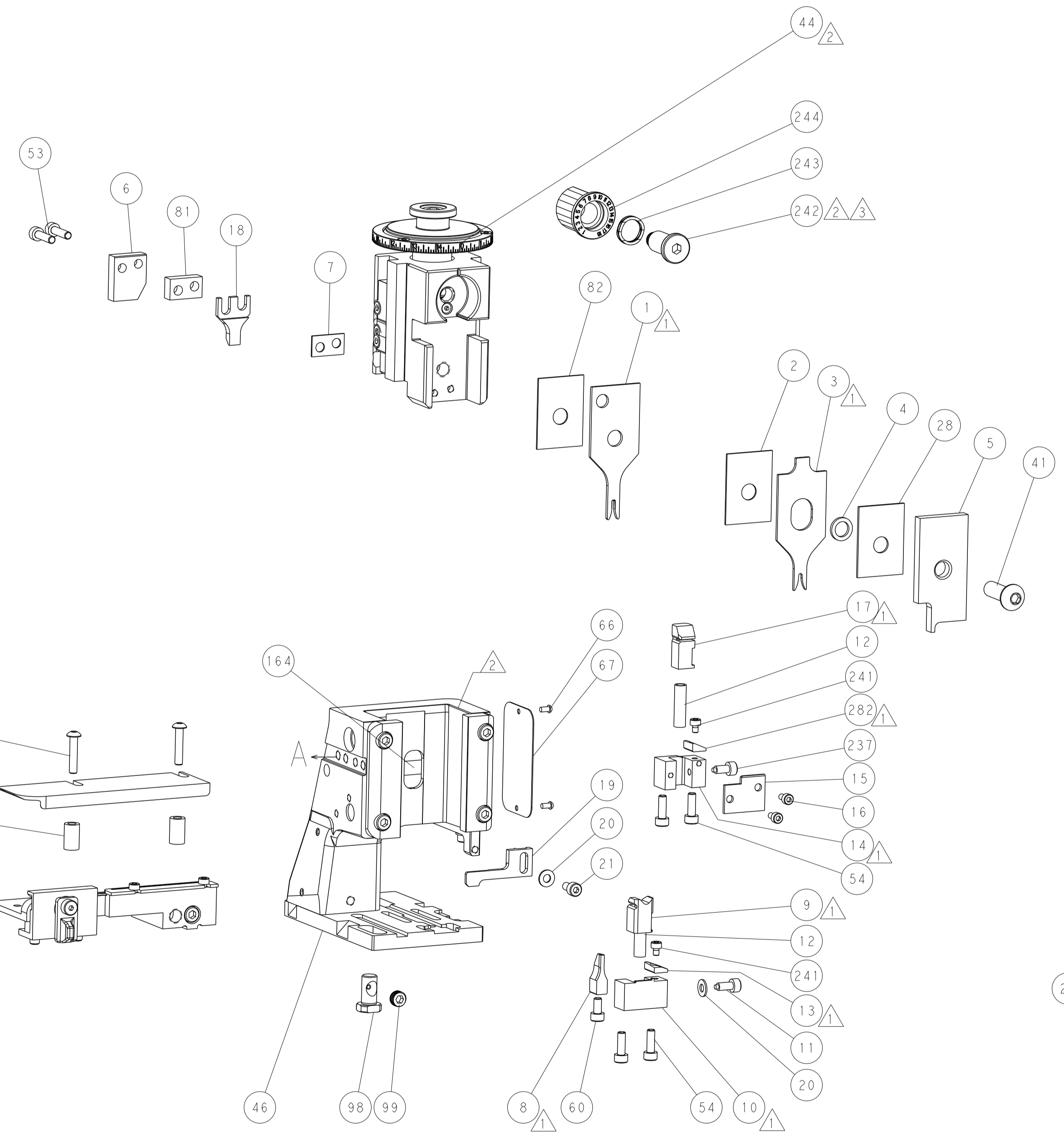
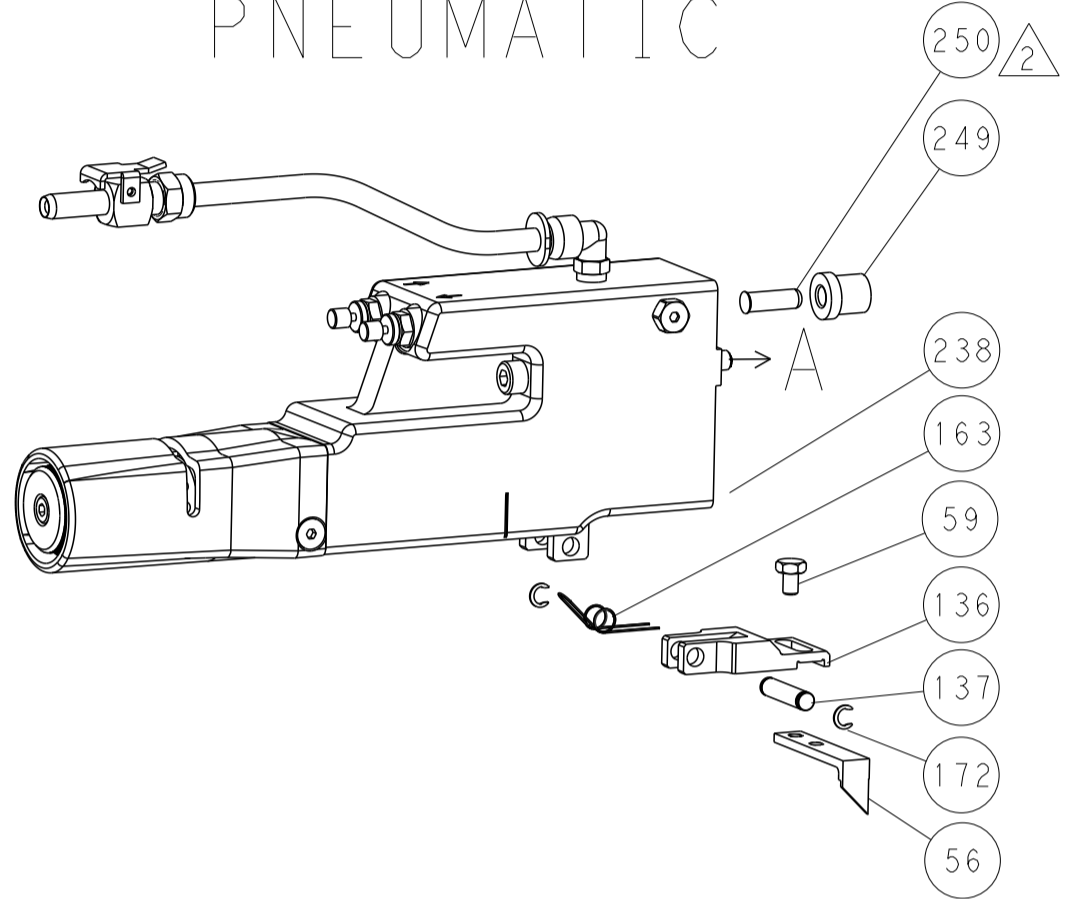

CAM POSITIONS

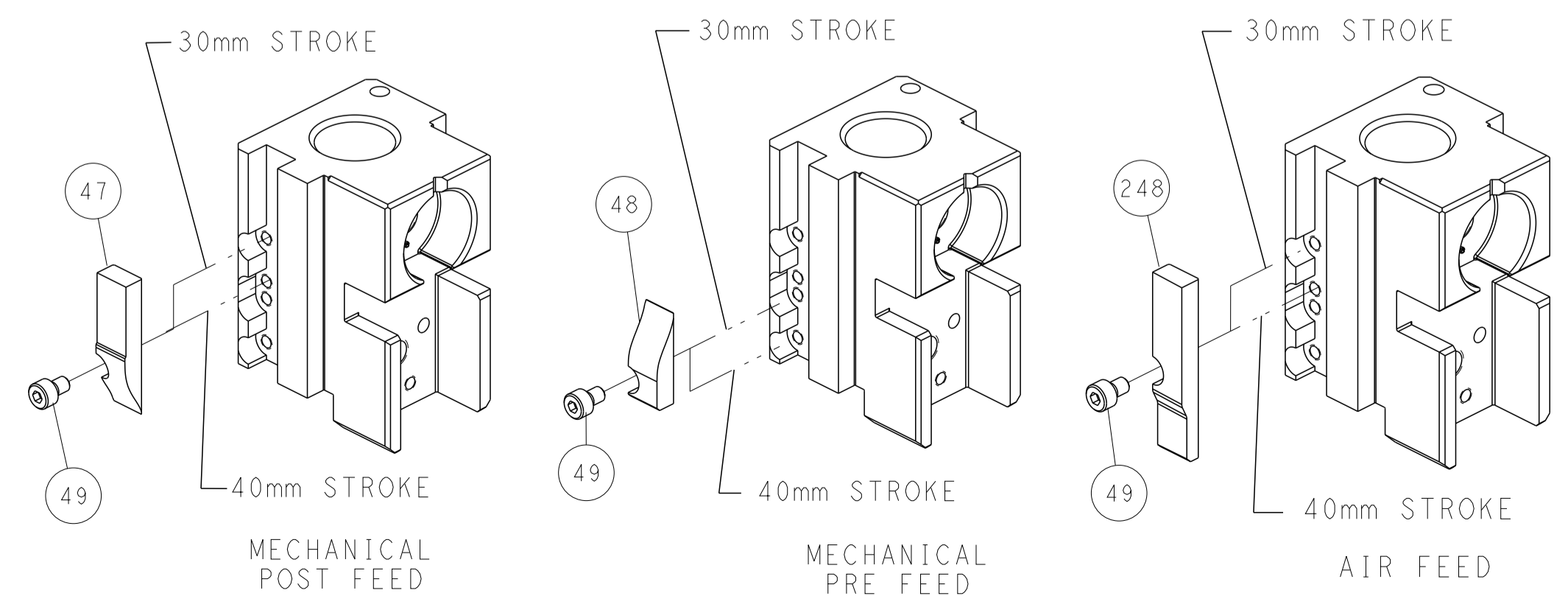

ATLANTIC VERSION
 Shown on sheets 1 of 4 & 2 of 4
 (Pacific version shown on sheets 3 of 4 & 4 of 4)

DIMENSIONS:		TOLERANCES UNLESS OTHERWISE SPECIFIED:		DWN STAKEM 28DEC2012		TE Connectivity	
mm	0 PLC ±	1 PLC ±	2 PLC ±	3 PLC ±	4 PLC ±	Harrisburg, PA 17105-3608	
	ANGLES ±			CHK G. BAILEY 28DEC2012	NAME		
	FINISH			APVD T. ELBIN 28DEC2012	Ocean Side Feed Applicator		
MATERIAL				PRODUCT SPEC	SIZE	CAGE CODE	DRAWING NO
				APPLICATION SPEC	A1	00779	©=2151843
				WEIGHT	Customer Accessible Production Drawing		RESTRICTED TO
				SCALE	1:1	SHEET 1 of 4	REV D

PART NUMBER	REVISION	DESCRIPTION	FEED TYPE
2-2151843-1	D	FINE CRIMP HEIGHT ADJUST	MECHANICAL
2-2151843-2	D	FINE CRIMP HEIGHT ADJUST	PNEUMATIC
7-2151843-7	B	CRIMP TOOLING KIT	-

PACIFIC VERSION TERMINATOR
 INTERFACE ADAPTER



APPLICATOR DATA		
CRIMP	SIZE	TYPE
WIRE	1.57 mm [.062]	F
INSUL	2.03 mm [.080]	O
APPLICATOR INSTRUCTIONS 408-35042		

TERMINAL DATA: HIROSE TERMINAL		HIROSE CRIMP SPECIFICATION	
TERMINAL NAME: SOCKET			
WIRE STRIP LENGTH 2.00-2.50 mm [.079-.098 IN]		INSULATION DIAMETER RANGE Ø1.20-1.90 mm [.047-.075 IN]	
TERMINAL APPLICATION SPECIFICATION NONE			
TERMINALS APPLIED			
TE TERMINAL	HIROSE TERMINAL	TE TERMINAL	HIROSE TERMINAL
286890-1	DF1B-2022SCFA	286890-2	DF1B-2022SCF

WIRE SIZE	CRIMP HEIGHT mm [INCH]	CRIMP HEIGHT REFERENCE SETTING
20 AWG	0.88 +/- 0.03 [.035 +/- .001]	7.9
22 AWG	0.82 +/- 0.03 [.032 +/- .001]	9.0
24 AWG	0.77 +/- 0.03 [.030 +/- .001]	9.2

- RECOMMENDED SPARE PARTS
- REFER TO SUPPLIED INSTRUCTION SHEET FOR CLEANING, LUBRICATION AND STORAGE OF APPLICATOR.
- APPLY PART NUMBER 2-23419-6 LOCTITE TO THREADS OF ITEM 242.
- CRIMP HEIGHT REFERENCE SETTING WAS THE SETTING USED WHEN THE APPLICATOR WAS QUALIFIED AT THE FACTORY. ADJUSTMENT MAY BE NECESSARY WHEN RUNNING APPLICATOR IN THE FIELD.
- UNLESS SPECIFIED OTHERWISE TORQUE VALUES SHALL BE USED PER DOCUMENT, 101-35000.

***WARNING**
 ON INSTALLATION, SET WIRE DISC TO CRIMP HEIGHT REFERENCE SETTING FOR LARGEST WIRE SIZE. CRIMP HEIGHT REFERENCE SETTINGS GREATER THAN THE VALUE SHOWN MAY CAUSE DAMAGE TO THE CRIMP TOOLING. REFER TO THE INSTRUCTION SHEET FOR PROPER SETUP AND ADJUSTMENTS.

LOC	DIST	REVISIONS					
A	66	P	LTN	DESCRIPTION	DATE	OWN	APVD
-	-	-	-	SEE SHEET 1	-	-	-

△	-	1	1	2280441-1	INSERT, SHEAR		282
-	-	1	-	2119640-1	PUSH ROD, AIR FEED		250
-	-	1	-	1803259-1	BUSHING, FLANGED		249
-	-	1	1	2119082-8	CAM, SNAIL, INSULATION ADJUSTMENT		244
-	-	1	1	2079764-1	WASHER, WAVE SPRING, CREST-TO-CREST		243
△	-	1	1	2119083-1	RETAINER, INSULATION DIAL		242
-	-	2	2	7-18023-7	SCR, SKT HD CAP M3 X 4.0		241
-	-	-	1	2119580-1	MECHANICAL FEED ASSEMBLY		239
-	-	1	-	2063440-1	AIR FEED MODULE		238
-	-	1	1	356885-4	STOP, SHEAR		237
-	-	2	-	21045-3	RING, RETAIN, EXTERN, 3/16 CRESCENT		172
-	REF	REF	-	994970-2	COUNTER, MAGNETIC		164
-	-	1	-	240638-1	SPRING, FEED FINGER		163
-	-	1	-	2119641-2	FEED CAM, AIR FEED		151
-	-	1	1	2168083-8	SCR, SKT HD CAP, RoHS, M4 X 16		144
-	-	4	4	2168083-9	SCR, SKT HD CAP, RoHS, M4 X 20		143
-	-	-	1	2119653-2	FEED CAM, POST FEED		142
-	-	1	1	1-1803583-0	APPLICATOR BASIC ASSEMBLY, SF		141
-	-	1	1	1803516-1	RAM ASSEMBLY, SF PACIFIC		140
-	-	1	-	3-23627-7	PIN, RETAIN, GRVD, 3/16 X .854		137
-	-	1	-	2119799-1	HOLDER, FEED FINGER, AF		136
-	-	1	1	2844908-1	SCREW, LOCKING		99
-	-	1	1	2844907-1	POST, LOCKING		98
-	-	1	1	455888-7	SPACER, CRIMPER		82
-	-	1	1	8-240641-8	SPACER		81
-	-	1	1	1803607-1	DOCUMENTATION PACKAGE		71
-	-	1	1	2119740-1	TAG, IDENTIFICATION		67
-	-	2	2	2168078-1	SCREW, DRIVE, RH, RoHS, 2 x .188		66
-	-	1	1	5-18022-5	SCR, HEX HD CAP, M4 X 6.0		59
-	-	1	1	1338685-1	PAWL, FEED		56
-	-	2	2	2168083-8	SCR, SKT HD CAP, RoHS, M4 X 16		53
-	-	1	2	18023-9	SCR, SKT HD CAP M4 X 6.0		49
-	-	-	1	2119652-1	FEED CAM, PRE FEED		48
-	-	1	1	1803602-1	SCR, BHSC, RoHS (M8 X 25)		41
-	-	2	2	2079383-5	SCR, BHSC, RoHS (M4 X 20)		33
-	-	2	2	2-2844962-3	SPACER, CYLINDRICAL, STRIP GUIDE		30
-	-	1	1	2844992-1	ASSEMBLY, STRIP GUIDE		29
-	-	1	1	1-455888-0	SPACER, CRIMPER		28
-	-	1	1	1320928-2	STRIP GUIDE		24
-	-	1	1	2168083-2	SCR, SKT HD CAP, RoHS, M4 X 8.0		21
-	-	2	2	1-18028-2	WASHER, FLAT, REG M4		20
-	-	1	1	2119533-1	STRIPPER, SIDE FEED		19
-	-	1	1	1-690518-9	HOLD DOWN, TERMINAL		18
△	-	1	1	690463-1	FLOATING SHEAR, REAR		17
-	-	2	2	1-2168083-1	SCR, SKT HD CAP, RoHS, M3 X 6		16
△	-	1	1	1-690464-4	SHEAR PLATE, REAR		15
△	-	1	1	2119862-1	SHEAR HOLDER, REAR		14
△	-	1	1	2119806-1	INSERT, SHEAR		13
-	-	2	2	3-22280-3	SPRING, COMPRESSION		12
-	-	1	1	1-356885-4	STOP, SHEAR		11
△	-	1	1	2119805-1	SHEAR HOLDER, FRONT		10
△	-	1	1	1803095-6	FLOATING SHEAR, FRONT		9
△	1	1	1	1803336-5	ANVIL, COMBINATION		8
-	-	1	1	1-240641-9	SPACER		7
-	-	1	1	690468-1	DEPRESSOR SHEAR, REAR		6
-	-	1	1	2119757-4	DEPRESSOR, SHEAR		5
-	-	1	1	2-238011-5	BLOCK, CRIMPER SPACER		4
△	1	1	1	1803329-1	CRIMPER, INSULATION O PREMIUM		3
-	-	1	1	455888-7	SPACER, CRIMPER		2
△	1	1	1	1-1803325-1	CRIMPER, WIRE		1

PACIFIC VERSION
 Shown on sheets 3 of 4 & 4 of 4
 (Atlantic version shown on sheets 1 of 4 & 2 of 4)

DIMENSIONS:		TOLERANCES UNLESS OTHERWISE SPECIFIED:		DWG: STAKEM 28DEC2012		NAME: Ocean Side Feed Applicator	
mm	0 PLC ±	1 PLC ±	2 PLC ±	3 PLC ±	4 PLC ±	SIZE: A1	CAGE CODE: 00779
MATERIAL:		FINISH:		APVD: T. ELBIN 28DEC2012		DRAWING NO: 2151843	
				WEIGHT:		SCALE: 1:1	
				Customer Accessible Production Drawing		SHEET 1 OF 4	

LOC		DIST		REVISIONS			
A	66	P	LTM	DESCRIPTION	DATE	DWN	APVD
		-		SEE SHEET 1			

FEED TYPE MECHANICAL

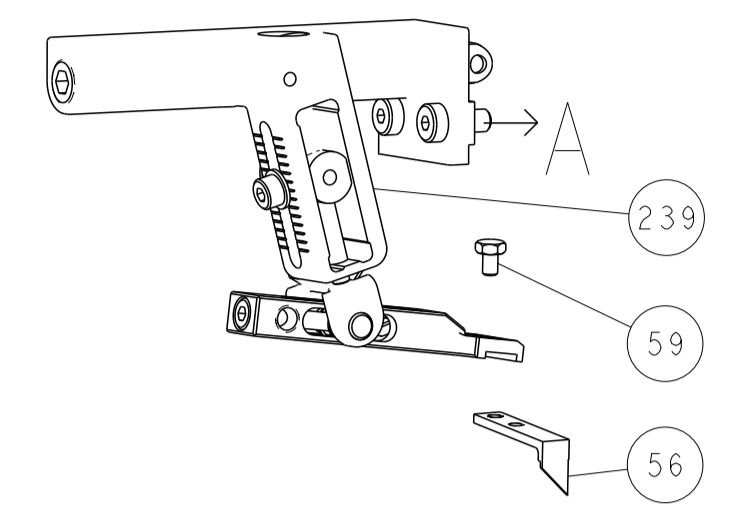

PNEUMATIC

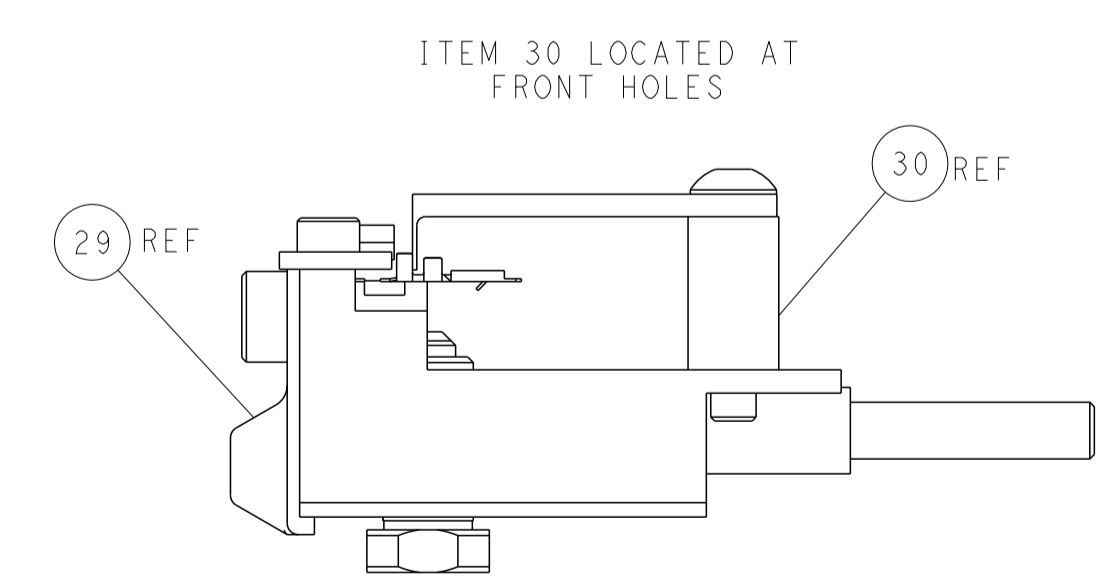
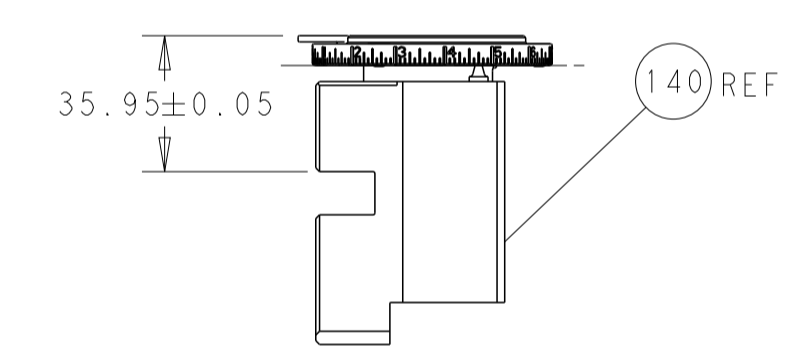
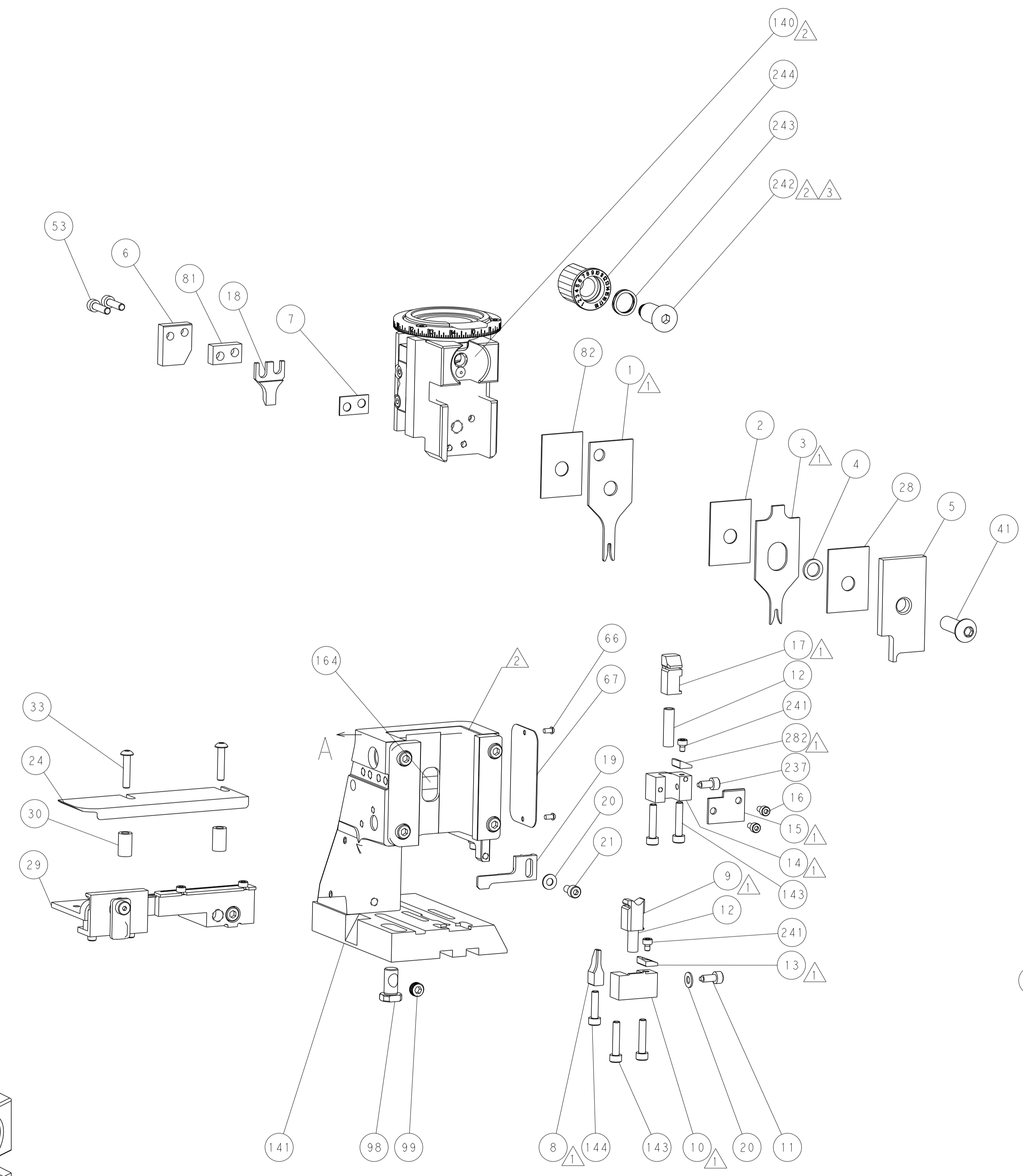
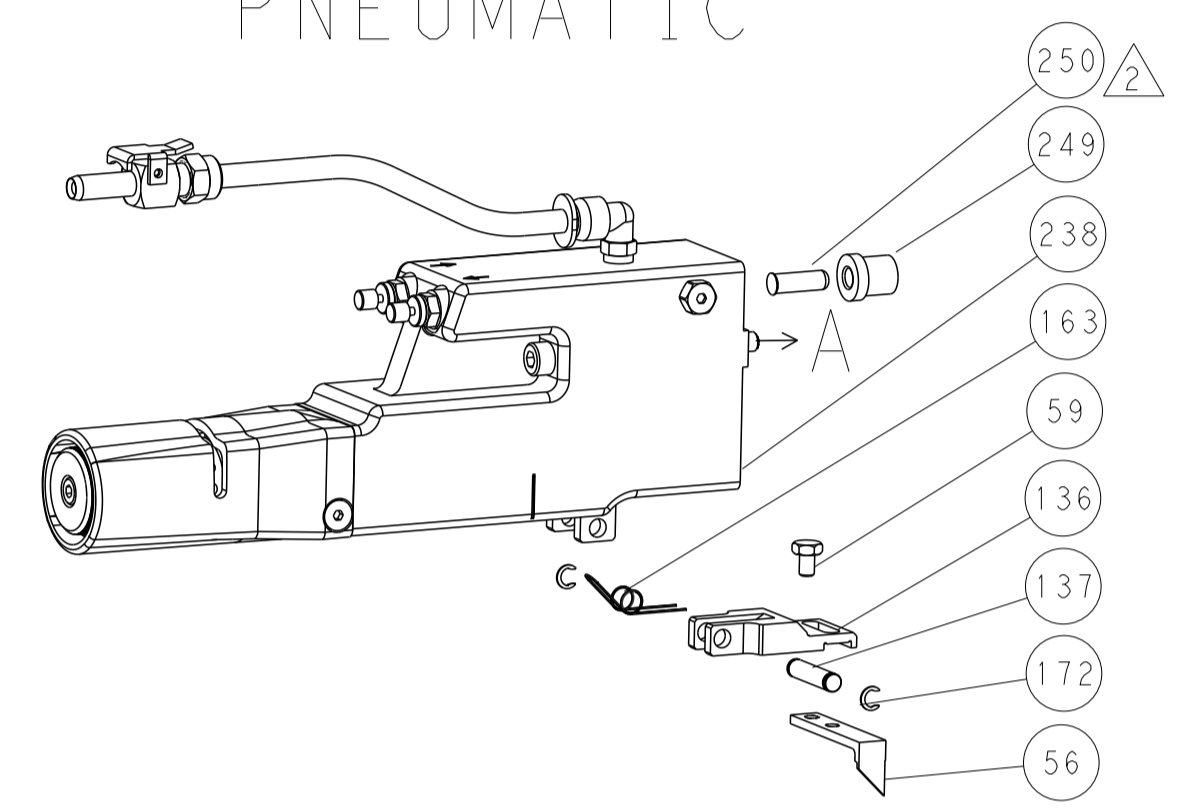

CAM POSITIONS

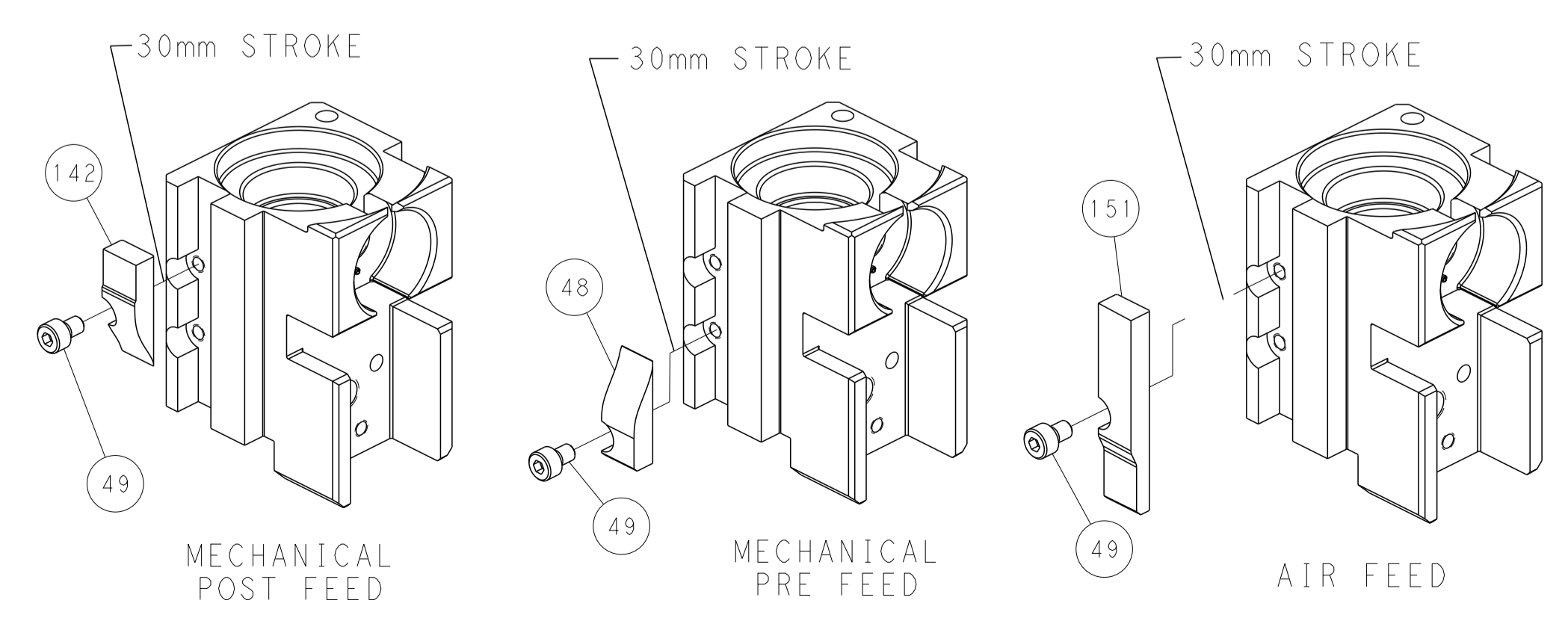

PACIFIC VERSION
 Shown on sheets 3 of 4 & 4 of 4
 (Atlantic version shown on sheets 1 of 4 & 2 of 4)

<small>THIS DRAWING IS UNPUBLISHED. RELEASED FOR PUBLICATION. ALL RIGHTS RESERVED.</small> <small>THIS DRAWING IS UNPUBLISHED. RELEASED FOR PUBLICATION. ALL RIGHTS RESERVED.</small>		DWN: STAKEM 28DEC2012 CHK: G. BAILEY 28DEC2012 APVD: T. ELBIN 28DEC2012	NAME: Ocean Side Feed Applier SIZE: A1 CAGE CODE: 00779 DRAWING NO: 2151843	RESTRICTED TO: - SCALE: 1:1 SHEET: 1 of 4 REV: D
DIMENSIONS: mm TOLERANCES UNLESS OTHERWISE SPECIFIED: 0 PLC ± 1 PLC ± 2 PLC ± 3 PLC ± 4 PLC ± ANGLES ± FINISH ±		STE TE Connectivity Harrisburg, PA 17105-3608 Customer Accessible Production Drawing		