

PART NUMBER	REV	FIRST USED
466906-2	C	463345-1

TERMINAL NAME:	
CONTACT TYPE III & V1	
PIN	SOCKET
66098	66100
66196	66198
66579	66580
163081	163083

CRIMPING DATA			
VISIBLE PAD LTR	CRIMP HEIGHT	WIRE SIZE	
A	NOT	USED	
B	NOT	USED	
C	NOT	USED	
D	.049 ±.002	16 OR 18 ⁴	
CRIMP SIZE	TYPE	RANGE	
WIRE .080	F	18 ⁴	
INSUL .120	0	.080-.100	
FEED	APPL INST	SET UP GAGE	LAYOUT
.500	SEE CUSTOMER MANUAL	NONE	161
WIRE STRIP LENGTH			
-			

LOC	DIST	REVISIONS			
F	LTR	DESCRIPTION	DATE	BY	APVD
A	66	C	ECR-08-016420	8-2008	MY GB

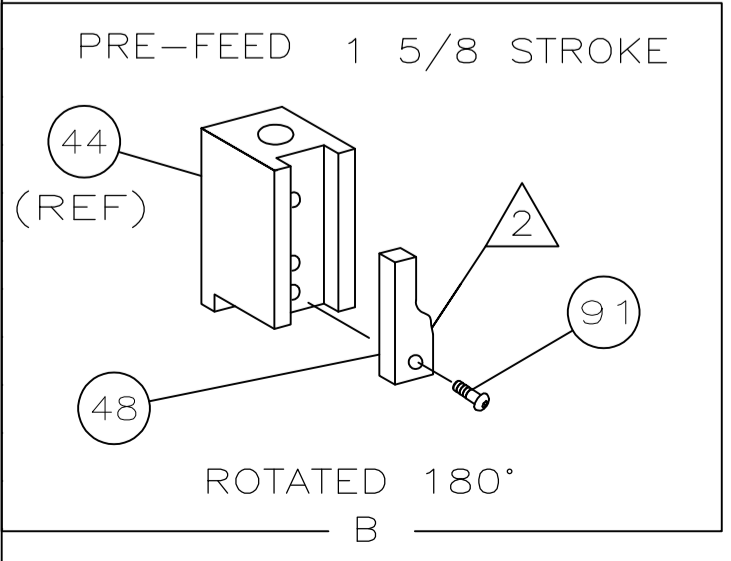
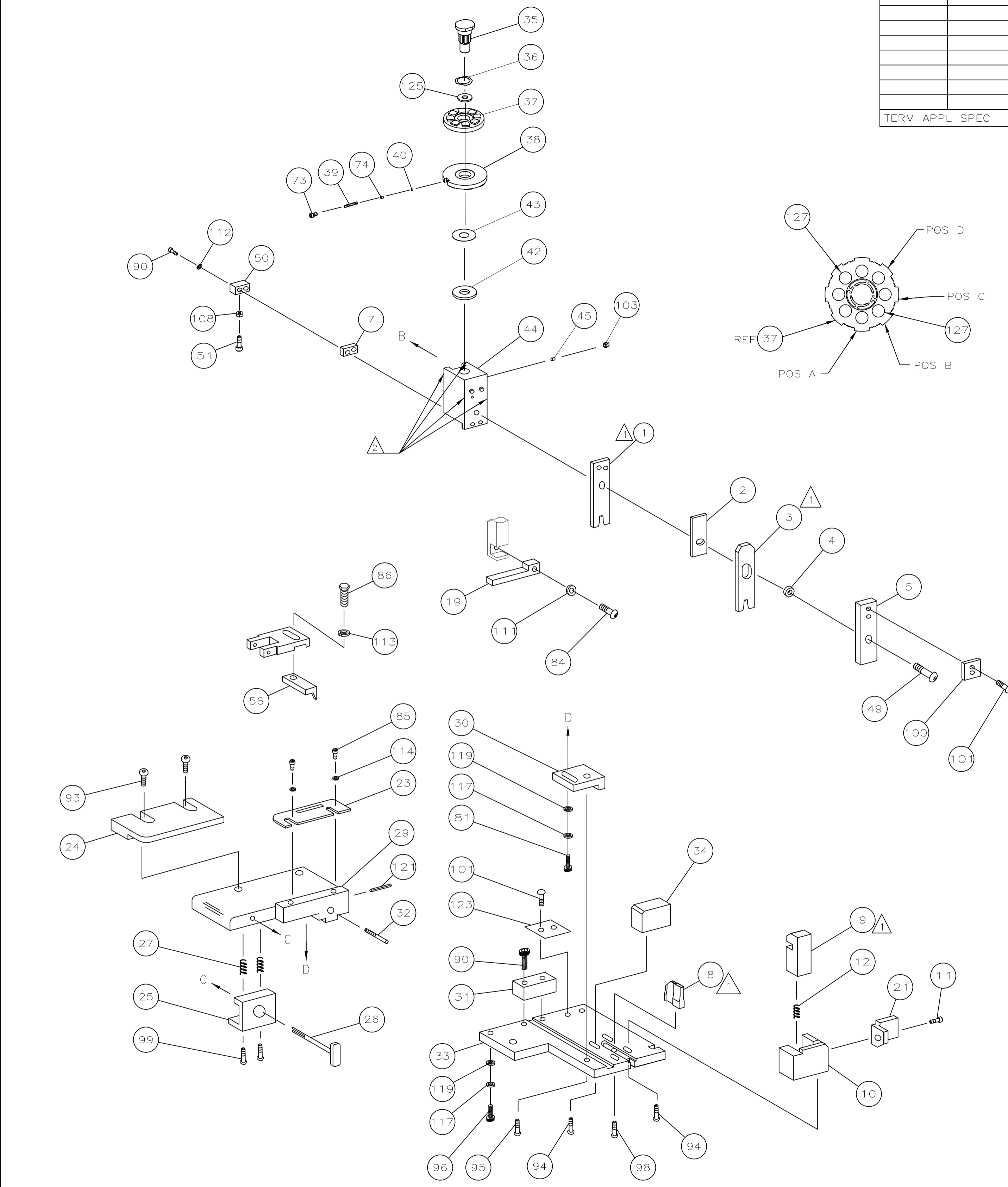

- 1 RECOMMENDED SPARE PARTS.
- 2 GREASE LIGHTLY.
- 3 ITEM NOT SHOWN
- 4 #16 WIRE IS NOT RECOMMENDED.
- 5 CUT TO LENGTH AT ASSEMBLY

IBM APPLICATOR

QTY	U/M	PART NO	DESCRIPTION	ITEM NO
2	-	3-354779-6	PIN, WIRE DISC (.3170)B	129
1	-	986950-1	WASHER, FLAT PRECISION	127
1	-	690701-2	PLATE, SERIAL NO.	126
1	-	4-21028-0	PIN,SLT SPR(Ø.093x.75)ST GDE PL	125
2	-	21899-2	WASHER,FLAT(#10)S G ADJ BLK	124
2	-	21024-5	WASHER, LOCK(#10)ADJ BLOCK	123
2	-	21024-2	WASHER,LOCK(#4)FRONT STP GUIDE	122
REF	-	21024-4	WASHER,LOCK(#8)FEED FINGER	121
2	-	21024-4	WASHER,LOCK(#8)DEP-HOLD	120
REF	-	21024-4	WASHER,LOCK(#8)STRIPPER	119
1	-	21018-5	NUT,HEX(#6)HOLD DOWN	118
4	-	21017-2	SCR,DRIVE(#2x.19)ID PLATE	117
1	-	819347-1	PLATE, IDENTIFICATION	116
2	-	3-21002-0	SCR,BHC(10-32x.88)DRAG	115
1	-	22733-8	SCR,BHC(8-32x.38 LW)ANVIL	114
1	-	3-21000-8	SCR,SHC(10-32x.88)MOUNTING	113
1	-	2-22733-1	SCR,BHC(10-32x.50)SG ADJ BLK	112
4	-	22733-9	SCR,BHC(8-32x.50)SHEAR-TERM SUP	111
2	-	2-21000-2	SCR,BHC(8-32x.50)R STP GDE	110
1	-	1-21002-7	SCR,SHC(6-32x.50)CAM	109
4	-	2-21000-8	SCR,SHC(8-32x.62)SCR BLK	108
REF	-	2-22603-0	SCR,HEX HD(8-32x.31)FEED FINGER	107
2	-	1-21000-3	SCR,SHC(4-40x.25)F ST GUIDE	106
REF	-	22733-9	SCR,BHC(8-32x.50 SL)STRIPPER	105
1	-	3-21000-4	SCR,SHC(10-32x.38)SG ADJ BL	104
2	-	463310-4	BLADE, STRIPPING (#18)	103
1	-	690603-1	SPRING, ASSIST	102
1	-	23030-1	SCR,SKT CAP(6-32x.25)CP DSC	101

QTY	U/M	PART NO	DESCRIPTION	ITEM NO
1	-	811242-2	BUMPER, HOLDDOWN	70
1	-	690753-1	SPACER, TONKER	69
1	-	7-21002-9	BOLT, CRIMPER(5/16x1.00)	68
1	-	690602-6	CAM, PRE-FEED 1.62 STROKE	67
1	-	690191-1	PLUG, NYLON	66
1	-	455673-1	RAM	65
1	-	690125-1	WASHER, LAMINATED	64
1	-	690124-1	WASHER, RAM	63
1	-	23241-6	BALL, STEEL	62
1	-	690170-1	SPRING, COMPRESSION	61
1	-	690142-1	DISC, INSULATION	60
1	-	354777-1	WIRE DISC, PLASTIC	59
1	-	22480-5	WASHER, SPRING	58
1	-	690212-1	POST, RAM	57
1	-	692776-1	SUPPORT, TERMINAL	56
1	-	462544-1	PLATE, BASE SPECIAL	55
1	-	690432-3	SCREW, ADJUSTMENT	54
1	-	462543-1	BLOCK, SCREW SPECIAL	53
1	-	455689-1	BLOCK, STRIP GUIDE ADJ	52
1	-	455671-1	PLATE, STRIP GUIDE	51
2	-	1-22284-0	SPRING, DRAG	50
1	-	690546-1	LEVER, DRAG RELEASE	49
1	-	240792-1	DRAG, TERMINAL	48
1	-	6-690504-2	GUIDE, STRIP (REAR)	47
1	-	690438-1	GUIDE, STRIP (FRONT)	46
1	-	463756-1	GUIDE, SCRAP	45
REF	-	462615-1	STRIPPER	44
1	-	3-22280-3	SPRING, SHEAR	43
1	-	690461-2	STOP, SHEAR (FRONT)	42
1	-	462548-1	HOLDER, SHEAR (FRONT) SP	41
1	-	462547-1	SHEAR, FLOAT (FRONT) SP	40
1	-	690514-3	ANVIL	39
1	-	3-240641-7	SPACER, DEPRESSOR (REAR)	38
1	-	462838-1	DEPRESSOR, SHEAR (FRONT) SP	37
1	-	2-238011-2	SPACER, BLOCK CRIMPER	36
1	-	2-456135-4	CRIMPER, INSULATION	35
1	-	455888-3	SPACER, CRIMPER	34
1	-	1-456405-6	CRIMPER, WIRE	33

THIS DRAWING IS A CONTROLLED DOCUMENT.

DIMENSIONS: INCHES. TOLERANCES UNLESS OTHERWISE SPECIFIED: 0 PLC ±.0005, 1 PLC ±.0008, 2 PLC ±.0010, 3 PLC ±.0015, 4 PLC ±.0020, ANGLES ±.0010.

MATERIAL: FINISH: WEIGHT: SCALE: SHEET 1 OF 1 REV C

APPROVED: E. KOOTTE, PRODUCT SPEC. APPLICATION SPEC. SIZE: A1, CASE CODE: 00779, DRAWING NO: 466906-2, CUSTOMER DRAWING.

Tyco Electronics Corporation, Harrisburg, PA 17105-3608. STRIPPER CRIMPER APPLICATOR.