



ZMOTION® Lenses

Product Specification

PS028610-1114





Warning: DO NOT USE THIS PRODUCT IN LIFE SUPPORT SYSTEMS.

LIFE SUPPORT POLICY

ZILOG'S PRODUCTS ARE NOT AUTHORIZED FOR USE AS CRITICAL COMPONENTS IN LIFE SUPPORT DEVICES OR SYSTEMS WITHOUT THE EXPRESS PRIOR WRITTEN APPROVAL OF THE PRESIDENT AND GENERAL COUNSEL OF ZILOG CORPORATION.

As used herein

Life support devices or systems are devices which (a) are intended for surgical implant into the body, or (b) support or sustain life and whose failure to perform when properly used in accordance with instructions for use provided in the labeling can be reasonably expected to result in a significant injury to the user. A critical component is any component in a life support device or system whose failure to perform can be reasonably expected to cause the failure of the life support device or system or to affect its safety or effectiveness.

Document Disclaimer

©2014 Zilog, Inc All rights reserved. Information in this publication concerning the devices, applications, or technology described is intended to suggest possible uses and may be superseded. ZILOG, INC. DOES NOT ASSUME LIABILITY FOR OR PROVIDE A REPRESENTATION OF ACCURACY OF THE INFORMATION, DEVICES, OR TECHNOLOGY DESCRIBED IN THIS DOCUMENT. ZILOG ALSO DOES NOT ASSUME LIABILITY FOR INTELLECTUAL PROPERTY INFRINGEMENT RELATED IN ANY MANNER TO USE OF INFORMATION, DEVICES, OR TECHNOLOGY DESCRIBED HEREIN OR OTHERWISE. The information contained within this document has been verified according to the general principles of electrical and mechanical engineering.

ZMOTION and Z8 Encore! XP are trademarks or registered trademarks of Zilog, Inc. (An IXYS Company). All other product or service names are the property of their respective owners.

Revision History

Each instance in the revision history table reflects a change to this document from its previous revision. For more details, refer to the corresponding pages or appropriate links provided in the table below.

Date	Revision Level	Description	Page
Nov 2014	10	Changed focus of spec to cover ZMOTION lenses only; see related ZMOTION Pyroelectric Sensors Product Specification (PS0336).	All
Feb 2013	09	Moved NCL-11 lens specification to Table 1 ; added the CM 0.77 GI V2 lens specification; alphanumerically reordered all lenses.	2 , 7
May 2012	08	Added the NCL-11 and EWA 0.3 GI V2 lens specifications.	35 , 17
Nov 2011	07	Added the NCL-3R and NCL-10S lens specifications.	21 , 33
Mar 2011	06	Intrusion lens specifications added.	37
Jan 2011	05	Modifications to some lens/sensor descriptions in Table 1 .	2
Jan 2011	04	Updated to include two new Nicera sensors.	18 , 28
Nov 2010	03	Updated to new Zilog/IXYS logo and accepted Zilog style; replaced all instances of <i>ePIR</i> with <i>advanced passive infrared</i> .	All
Sep 2010	02	Replaced Zilog logos, ePIR with ZMOTION, and Zdots with Module; fixed formatting and pagination issues; removed references to GP and General Purpose.	All
Oct 2010	01	Original issue	All



Table of Contents

- Revision History iii
- List of Figures v
- List of Tables vi
- Overview 1
- ZMOTION Lens Selection Guide 2
- ZMOTION Detection and Control Lens Specifications 5
 - ZAA09GIT1 Lens Specification 6
 - ZCM077GIV2 Lens Specification 7
 - ZCM077GIV3 Lens Specification 9
 - ZCM077GIV5 Lens Specification 11
 - ZCWM05GIV1 Lens Specification 14
 - ZEWA03GIV2 Lens Specification 17
 - ZNCL3B Lens Specification 18
 - ZNCL10R Lens Specification 21
 - ZNCL926 Lens Specification 25
 - ZNCL10IL Lens Specification 28
 - ZNCL10S Lens Specification 33
 - ZNCL11 Lens Specification 35
- ZMOTION Intrusion Detection Lens Specifications 37
 - ZLR12GI12V3 Lens Specification 38
 - ZVB12GIV1 Lens Specification 39
 - ZWA12GI12V4 Lens Specification 40
- Related Documents 41
- Customer Support 42

List of Figures

Figure 1.	The ZAA09GIT1 Lens Specification	6
Figure 2.	The ZCM077GIV2 Lens Specification: Front View	7
Figure 3.	The ZCM077GIV2 Lens Specification: Floor Coverage, Side View	8
Figure 4.	The ZCM077GIV3 Lens Specification, #1 of 2	9
Figure 5.	The ZCM077GIV3 Lens Specification, #2 of 2	10
Figure 6.	The ZCM077GIV5 Lens Specification, #1 of 3	11
Figure 7.	The ZCM077GIV5 Lens Specification, #2 of 3	12
Figure 8.	The ZCM077GIV5 Lens Specification, #3 of 3	13
Figure 9.	The ZCWM05GIV1 Lens Specification: Wall Mount	15
Figure 10.	The ZCWM05GIV1 Lens Specification: Ceiling Mount, #1 of 2	16
Figure 11.	The ZCWM05GIV1 Lens Specification: Ceiling Mount, #2 of 2	17
Figure 12.	The ZEWA03GIV2 Lens Specification, Dimensions	18
Figure 13.	The ZNCL3B Lens Dimensions	19
Figure 14.	The ZNCL3B Lens Specification, X Axis	20
Figure 15.	The ZNCL3B Lens Specification, Y Axis	21
Figure 16.	The ZNCL10R Lens Specification, Dimensions	22
Figure 17.	The ZNCL10R Dual-Element Lens Specification, Tab Direction A	23
Figure 18.	The ZNCL10R Dual-Element Lens Specification, Tab Direction B	24
Figure 19.	The ZNCL10R Quad-Element Lens Specification, Tab Direction A, X Axis	25
Figure 20.	The ZNCL926 Lens Specification, Dimensions	26
Figure 21.	The ZNCL926 Detection Area with Quad-Element PIR	27
Figure 22.	The ZNCL926 Detection Area with Dual-Element PIR	28
Figure 23.	The ZNCL10IL Lens Specification, Dimensions	29
Figure 24.	The ZNCL10IL Lens Specification, Tab Direction A, X Axis	30
Figure 25.	The ZNCL10IL Lens Specification, Tab Direction A, Y Axis	31
Figure 26.	The ZNCL10IL Lens Specification, Tab Direction B, X Axis	32
Figure 27.	The ZNCL10IL Lens Specification, Tab Direction B, Y Axis	33
Figure 28.	The ZNCL10S Lens Specification, Dimensions	34
Figure 29.	The ZNCL10S Dual-Element Lens Specification, X/Y Axes	35
Figure 30.	The ZNCL11 Lens Specification, Dimensions	36
Figure 31.	The ZNCL11 Detection Area, X/Y Axes	37
Figure 32.	ZLR12GI12V3 Lens Specification	39
Figure 33.	ZVB12GIV1 Lens Specification	40
Figure 34.	ZWA12GI12V4 Lens Specification	41



List of Tables

Table 1. ZMOTION Detection and Control Lenses 2
Table 2. ZMOTION Intrusion Detection Lenses 5

Overview

Zilog's ZMOTION Detection and Control and Intrusion Detection product families provide integrated and flexible solutions for Passive Infrared (PIR)-based motion detection applications. These product families are based on the ZMOTION MCU, a high-performance microcontroller featuring integrated PIR motion detection algorithms. Each family includes a selection of lenses and PIR sensors to fit a wide range of application requirements. Each lens combination is optimized for its intended application by configuration settings loaded into the ZMOTION MCU ensuring the best possible performance while significantly reducing development risk and minimizing time to market. Zilog's PIR Motion Detection Technology provides a dramatic improvement in both sensitivity and stability over traditional designs and is scalable to many market segments including Security/Intrusion Detection, Lighting Control, HVAC, Access Control, Vending, Display, Proximity, Power Management, Occupancy Sensing and many others.

This document provides the zone patterns and mechanical dimensions for the Zilog-supported lenses included in the ZMOTION Family. Each supported lens combination is provided with an associated configuration file for the ZMOTION MCU. It is possible to use other lenses not directly supported by Zilog by developing the appropriate configuration settings based on one of the existing files.

There are two general groups of lenses provided:

- ZMOTION Detection and Control for general motion detection applications
- ZMOTION Intrusion Detection for security applications

These lens groupings are based on typical usage; any of these lenses could be used for a variety of applications and are not limited to these suggested applications. All lenses listed in this document are available from Zilog or from their associated manufacturers. Because Zilog is regularly adding new lens support to these ZMOTION product families, please obtain the latest version of this document from our website at: www.zilog.com/ZMOTION.

► **Note:** To review the configuration files for specific lens and sensor combinations, refer to the [ZMOTION Detection Lens and Pyroelectric Sensor Configuration Guide \(WP0018\)](#).

ZMOTION Lens Selection Guide

Select a lens and pyroelectric sensor based on the intended application from Table 1. Lenses for security/intrusion-related applications are listed in Table 2. To see the specifications for lenses used in security and intrusion detection applications, refer to the [ZMOTION Pyroelectric Sensors Specification \(PS0336\)](#).

Table 1. ZMOTION Detection and Control Lenses

Part Number	Description	Recommended Applications	Recommended Pyroelectric Sensor(s)	Manufacturer and MFR Part Number
ZAA09GIT1 Lens Specification – see page 6	Animal Alley Array (88°) <ul style="list-style-type: none"> • 35.6mm x 49.9mm Flat Fresnel lens • 22.9mm focal length • 25 meter range • 22 equal segments 	Corner wall mount or very high ceiling with rectangular floor pattern <ul style="list-style-type: none"> • Warehouse Lighting (Bay Light) • Combined Intrusion and Lighting Control • HVAC 	ZRE200BP ZSBG446671	Fresnel Technologies Inc. AA 0.9 GI T1
ZCM077GIV2 Lens Specification – see page 7	Ceiling Mount Array (360°) <ul style="list-style-type: none"> • 37mm diameter circular lens • 19.6mm focal length • 12.2m radius at 3.7m height • 4:1 floor coverage diameter-to-height ratio 	Low height ceiling mount for commercial lighting control <ul style="list-style-type: none"> • Commercial HVAC 	ZSBG446671	Fresnel Technologies Inc. CM 0.77 GI V2
ZCM077GIV3 Lens Specification – see page 9	Ceiling Mount Array (360°) <ul style="list-style-type: none"> • 37mm diameter circular lens • 19.6mm focal length • 3.7m radius at 2.4m height • 3:1 floor coverage diameter to height ratio 	Ceiling Mount for standard commercial heights <ul style="list-style-type: none"> • Lighting Control • HVAC Control • Meeting rooms 	ZSBG446671	Fresnel Technologies Inc. CM 0.77 GI V3

Table 1. ZMOTION Detection and Control Lenses (Continued)

Part Number	Description	Recommended Applications	Recommended Pyroelectric Sensor(s)	Manufacturer and MFR Part Number
ZCM077GIV5 Lens Specification – see page 11	Ceiling Mount Array (360°) <ul style="list-style-type: none"> • 37mm diameter circular lens • 19.6mm focal length • 12.2m radius at 12.2m height • 2:1 floor coverage diameter to height ratio 	High ceiling mount for commercial and industrial applications <ul style="list-style-type: none"> • Commercial Lighting Control • Commercial HVAC Control 	ZSBG446671	Fresnel Technologies Inc. CM 0.77 GI V5
ZCWM05GIV1 Lens Specification – see page 14	Ceiling Mount Array (360° oval pattern) <ul style="list-style-type: none"> • Wall mount array (~100°, ~8m coverage) • Circular lens with 24mm x 24mm square base • 14.2mm focal length • Board mount clip-in 	Wall or ceiling mount for office or meeting room <ul style="list-style-type: none"> • Room Lighting and HVAC Control 	ZRE200BP ZSBG323671	Fresnel Technologies Inc. CWM 0.5 GI V1
ZEWA03GIV2 Lens Specification – see page 17	Extra Wide Angle Wall Mount Array (180°) <ul style="list-style-type: none"> • 14mm x 28mm • 7.6mm focal length • 5 meter range • 16 equal segments 	Room occupancy and proximity sensing 180° detection with a single pyro <ul style="list-style-type: none"> • Wall mount room lighting control • AC light switch replacement • Hotel room thermostats 	ZRE200BP ZSBG323671	Fresnel Technologies Inc. EWA 0.3 GI V2
ZNCL3B Lens Specification – see page 18	10mm wall mount array (60° x 60°) <ul style="list-style-type: none"> • Clips on to pyroelectric sensor • 2 beams (X); 2 beams (Y) • 10m range 	Proximity or Entrance Detection <ul style="list-style-type: none"> • Kiosk • Vending • HVAC • Display counters • Under-cabinet Lighting 	ZRE200BP ZSBG323671	Nippon Ceramic Co., Ltd. (Nicera) NCL-3B
ZNCL10R Lens Specification – see page 21	10mm Ceiling Mount <ul style="list-style-type: none"> • Array (90° x 77°) • Clips on to pyroelectric sensor 	Proximity or Entrance Detection <ul style="list-style-type: none"> • HVAC • Display counters • Lighting Controls 	ZSBG446671 ZRE200BP ZSBG323671	Nippon Ceramic Co., Ltd. (Nicera) NCL-10R

Table 1. ZMOTION Detection and Control Lenses (Continued)

Part Number	Description	Recommended Applications	Recommended Pyroelectric Sensor(s)	Manufacturer and MFR Part Number
ZNCL926 Lens Specification – see page 25	Clip-on 15mm Array (360°) <ul style="list-style-type: none"> Clips on to pyroelectric sensor 2.5m radius at 2.5m height 2:1 Floor coverage diameter to height ratio 	Room Occupancy and Proximity Sensing <ul style="list-style-type: none"> Lighting Control HVAC Control Appliance Kiosk/Display Control Vending Power Management Appliance Power Management 	ZRE200BP ZSBG323671 ZSBG446671	Nippon Ceramic Co., Ltd. (Nicera) NCL-9(26)
ZNCL10IL Lens Specification – see page 28	10mm Wall/Ceiling Mount Array (80° x 30°) <ul style="list-style-type: none"> Clips on to pyroelectric sensor 6 beams (X); 2 beams (Y) 10m range 	Proximity or Entrance Detection <ul style="list-style-type: none"> Kiosk Vending HVAC Display counters 	ZRE200BP ZSBG323671	Nippon Ceramic Co., Ltd. (Nicera) NCL-10IL
ZNCL10S Lens Specification – see page 33	10mm wall mount (27°) directional <ul style="list-style-type: none"> Clips on to pyroelectric sensor 2 beams (X), 1 beam (Y) 10m range 	Entrance detection Kiosk Vending HVAC Display counters Directional Detection	ZRE200BP ZSBG323671	Nippon Ceramic Co., Ltd. (Nicera) NCL-10S
ZNCL11 Lens Specification – see page 35	Wall mount array 104° (X), 37° (Y) <ul style="list-style-type: none"> 32 detection zones Circuit board mount, black rectangular lens 4m range 	Room occupancy and proximity sensing <ul style="list-style-type: none"> Consumer electronics and appliance power management Display power management TV auto shutoff Keypad motion detector 	ZRE200BP ZSBG323671	Nippon Ceramic Co., Ltd. (Nicera) NCL-11

Table 2. ZMOTION Intrusion Detection Lenses

Part Number	Description	Typical Applications	Configuration Header File	Pyroelectric Sensor
ZLR12GI12V3 Lens Specification – see page 38	Long Range Array 42.6mm x 61.0mm Flat Fresnel 30.5mm (1.2") focal length 30.5m (100') range 3:1 floor coverage diameter to height ratio	Wall-mount long range corridor/hallway security/intrusion motion detector	ZRE200BP ZSBG446671	Fresnel Technologies Inc. LR 1.2 GI 12 V3
ZVB12GIV1 Lens Specification – see page 39	Vertical Barrier Array 42.6mm x 61.0mm Flat Fresnel 30.5mm (1.2") focal length 15 meter range, horizontal 7m range, vertical	Wall- or ceiling-mount curtain or vertical barrier security/intrusion motion detector	ZRE200BP ZSBG446671	Fresnel Technologies Inc. VB 1.2 GI V1
ZWA12GI12V4 Lens Specification – see page 40	Wide Angle Array (88°) 42.6mm x 61.0mm Flat Fresnel 30.5mm (1.2") focal length 18 meter range	Corner/Wall Mount security/intrusion motion detector <ul style="list-style-type: none"> • Pet immunity detector • Wide-area security motion detector 	ZRE200BP ZSBG446671	Fresnel Technologies Inc. WA 1.2 GI 12 V4

ZMOTION Detection and Control Lens Specifications

Figures 1 through 27 on the following pages discuss the specifications of the lenses selected for the ZMOTION Detection and Control family of products. To see specifications for lenses used in security and intrusion detection applications, refer to the [ZMOTION Intrusion Detection Lens Specifications](#) section on page 37.

ZAA09GIT1 Lens Specification

The ZAA09GIT1 lens array is optimized for dual-element pyroelectric sensors in long range sensing applications. It is normally used with the grooved side facing the pyroelectric detector, and curved at a 0.9 inch (22.9mm) radius about the sensitive area of the detector. The detector position should be 0.492" (12.5mm) below the upper edge, and centered left-right.

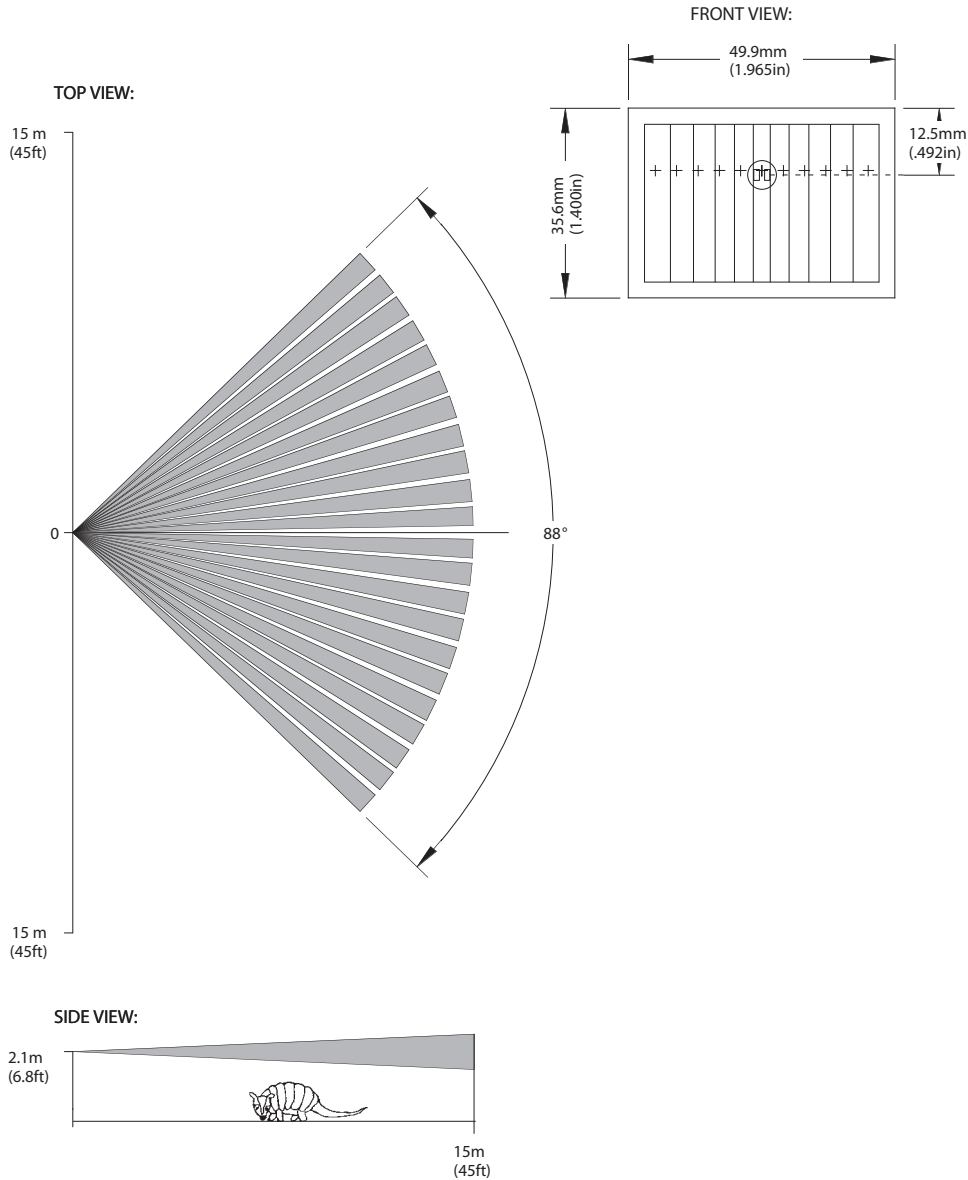

Figure 1. The ZAA09GIT1 Lens Specification

ZCM077GIV2 Lens Specification

The ZCM077GIV2 lens is intended for high ceiling-mounted commercial lighting and HVAC applications in which high floor coverage is required. See Figures 2 and 3.

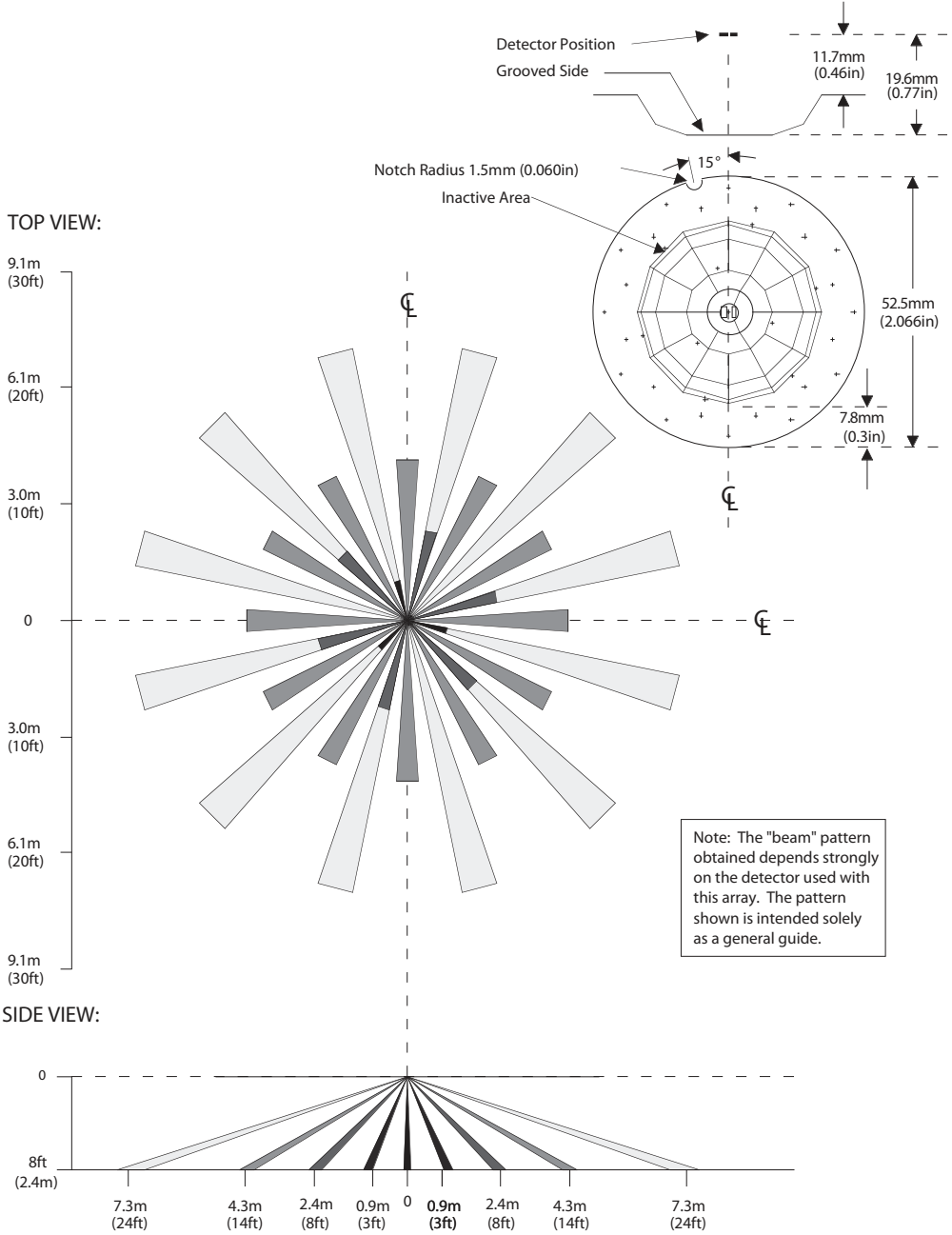
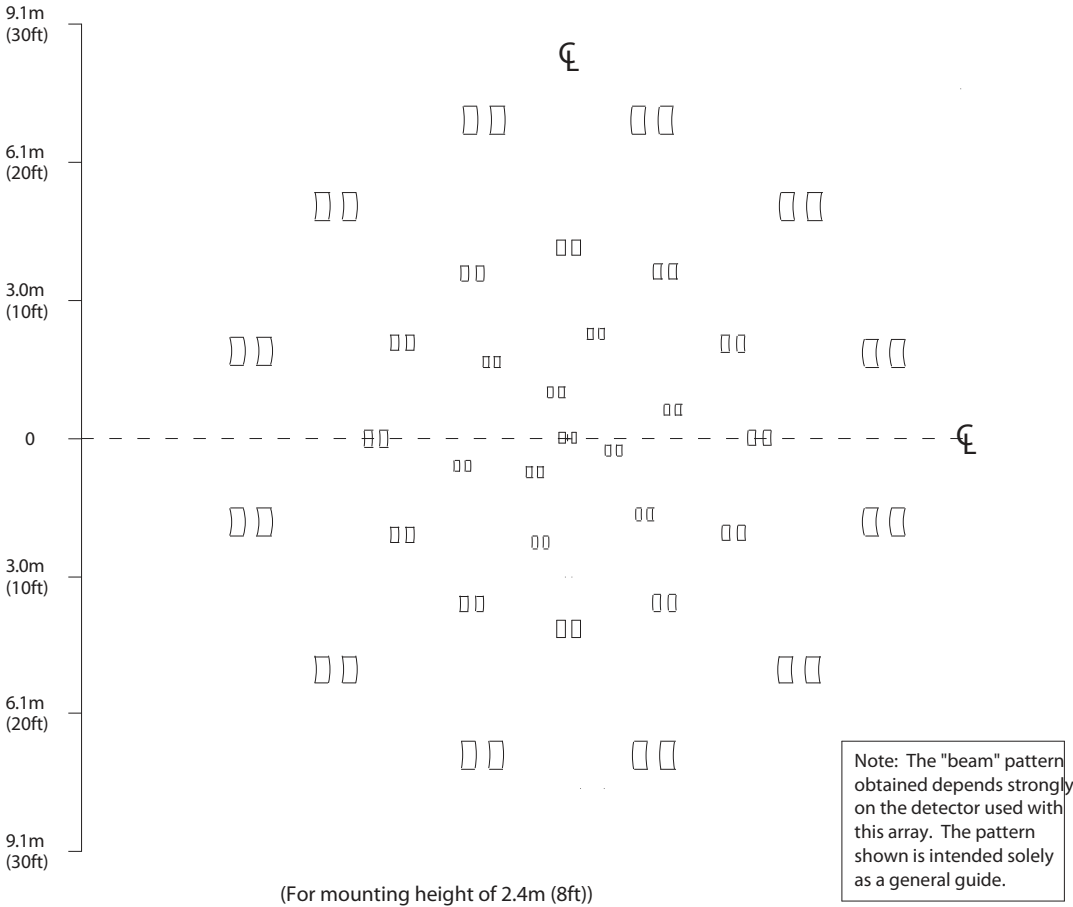

Figure 2. The ZCM077GIV2 Lens Specification: Front View



SIDE VIEW:

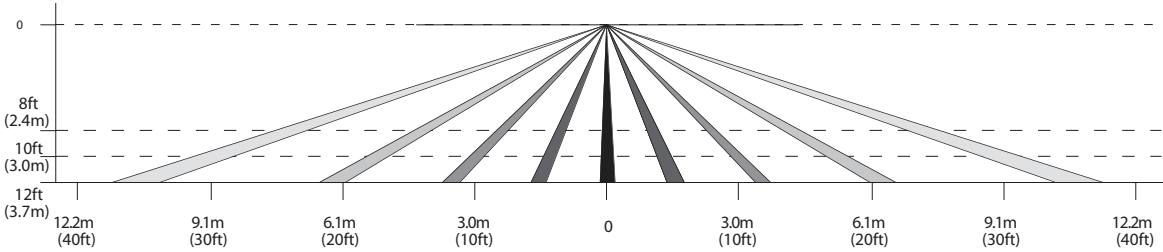

Figure 3. The ZCM077GIV2 Lens Specification: Floor Coverage, Side View

ZCM077GIV3 Lens Specification

The ZCM077GIV3 lens array is intended for ceiling-mounted applications and is optimized for use with both dual and quad element pyroelectric sensors. The detector mounting flange should be 0.46" (11.7 mm) from the pyroelectric sensor's element. The angle from the center line to the placement notch is 15 degrees.

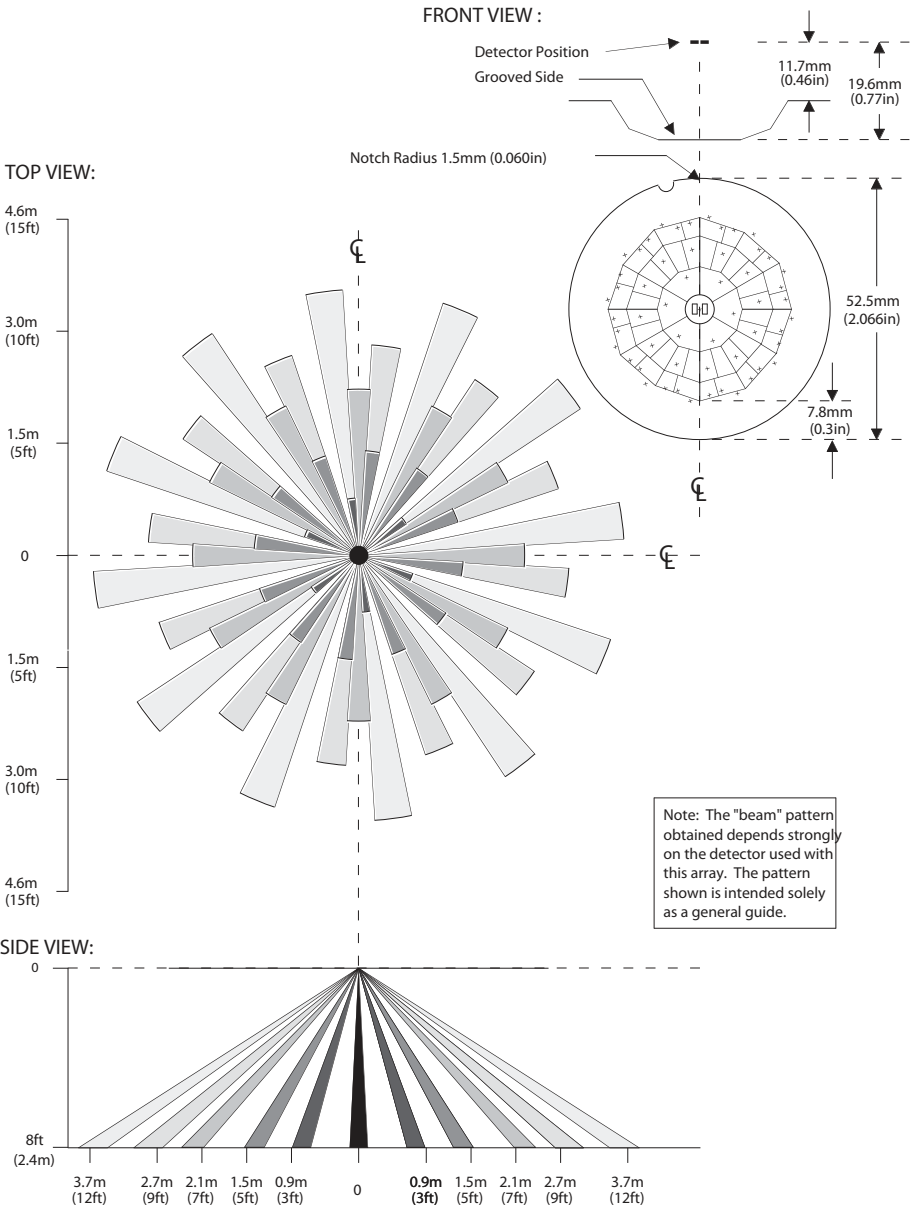

Figure 4. The ZCM077GIV3 Lens Specification, #1 of 2

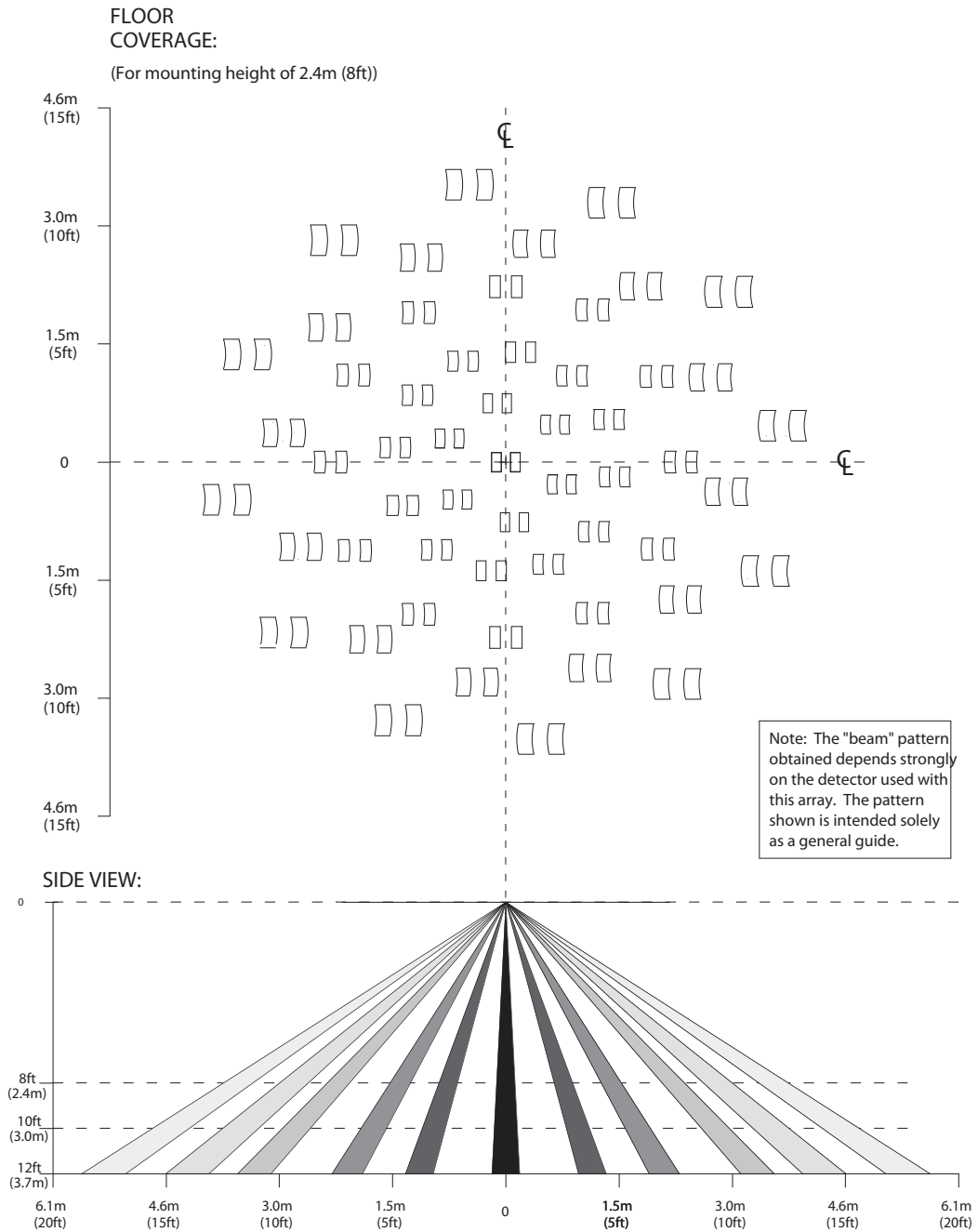

Figure 5. The ZCM077GIV3 Lens Specification, #2 of 2

ZCM077GIV5 Lens Specification

The ZCM077GIV5 lens array is intended for ceiling-mounted applications and is optimized for both dual and quad element pyroelectric detectors. The detector mounting flange should be 0.46" (11.7 mm) from the pyroelectric sensor's element.

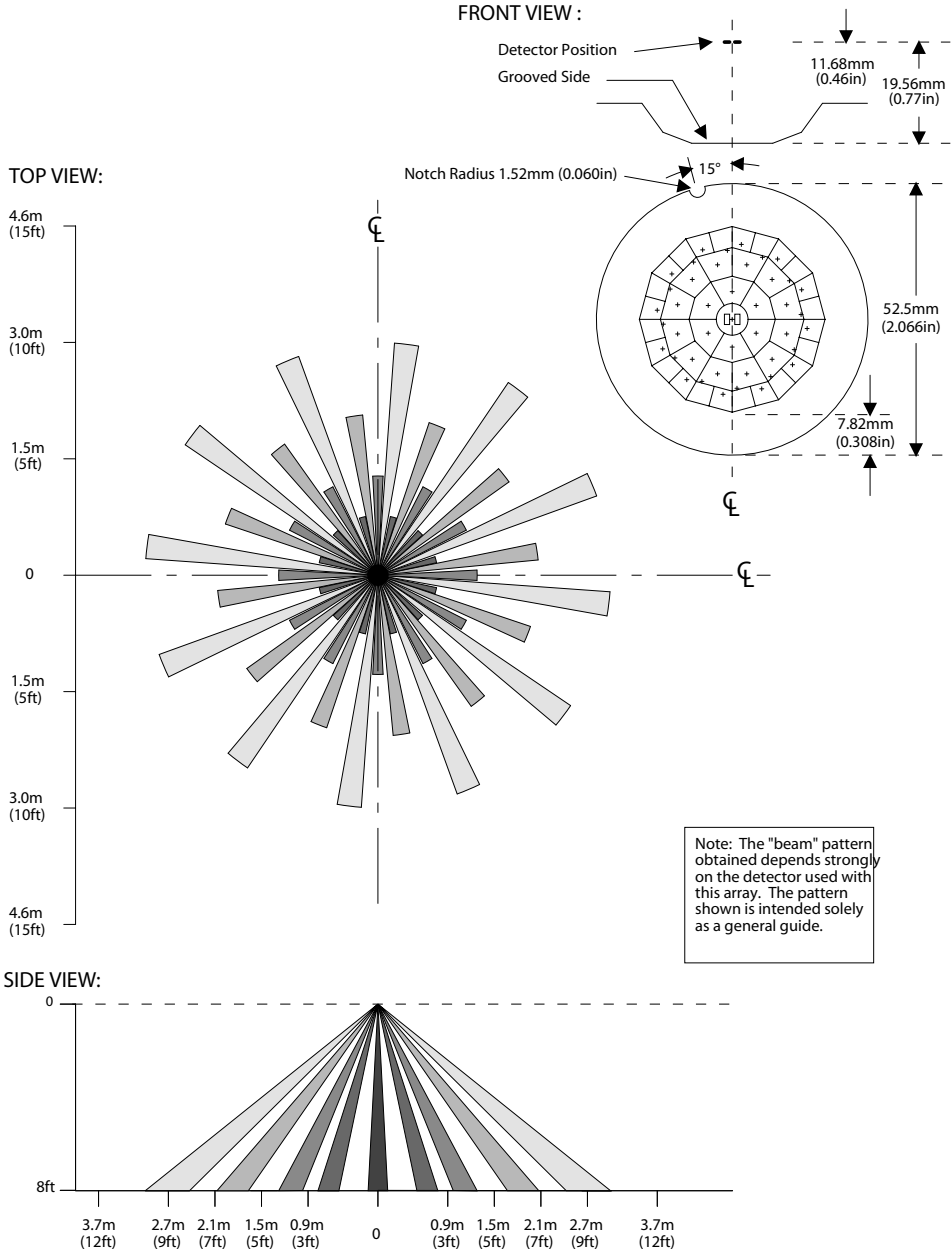

Figure 6. The ZCM077GIV5 Lens Specification, #1 of 3

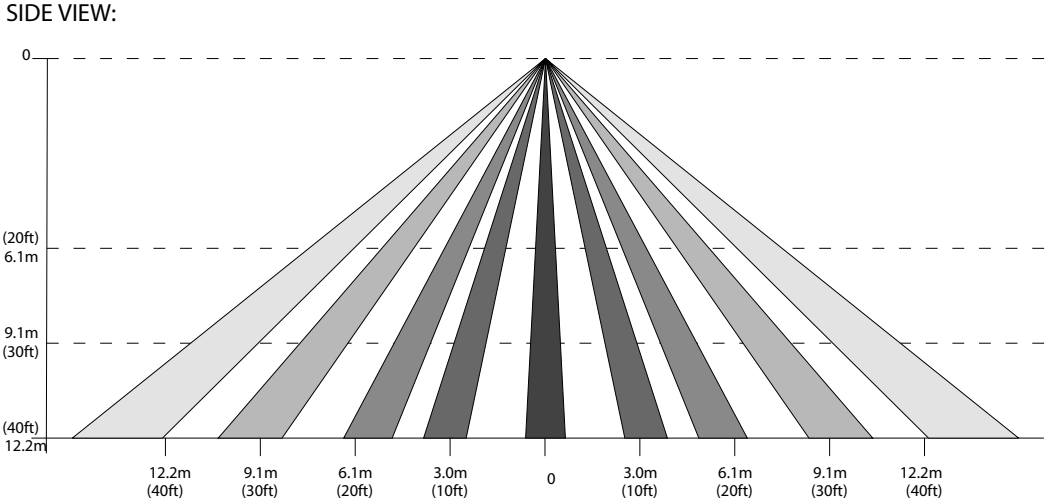
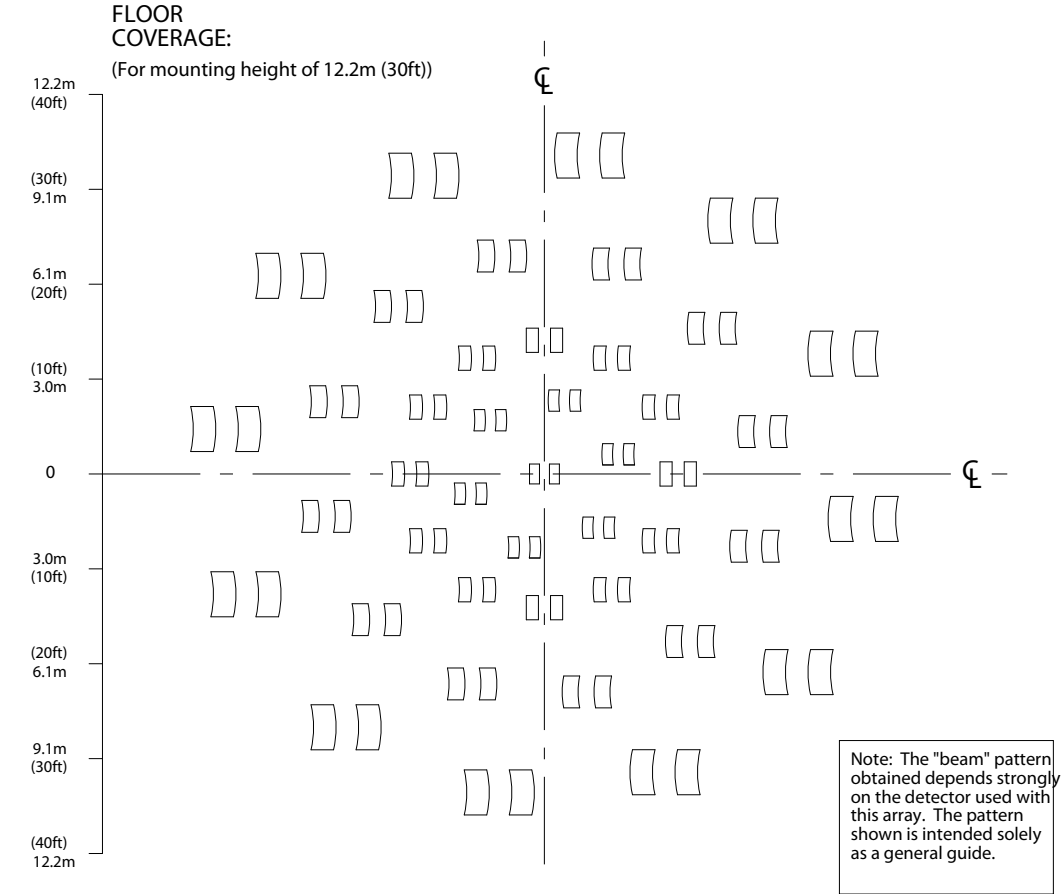

Figure 7. The ZCM077GIV5 Lens Specification, #2 of 3

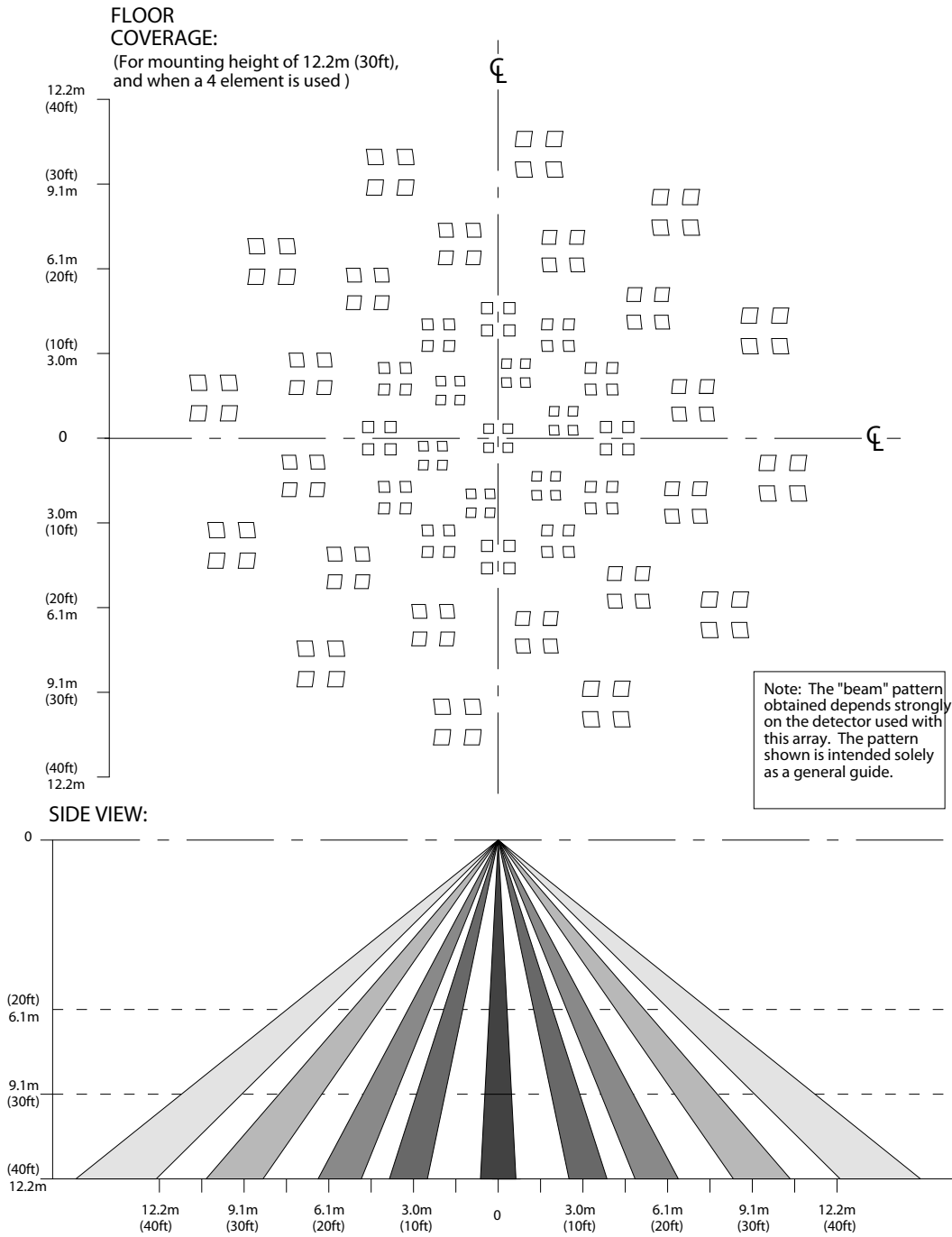

Figure 8. The ZCM077GIV5 Lens Specification, #3 of 3

ZCWM05GIV1 Lens Specification

The CWM 0.5 GI V1 lens array is intended for both wall and ceiling-mounted applications and is optimized for both dual and quad element pyroelectric detectors. The lens is intended to clip directly into the circuit board over top of the pyroelectric sensor.

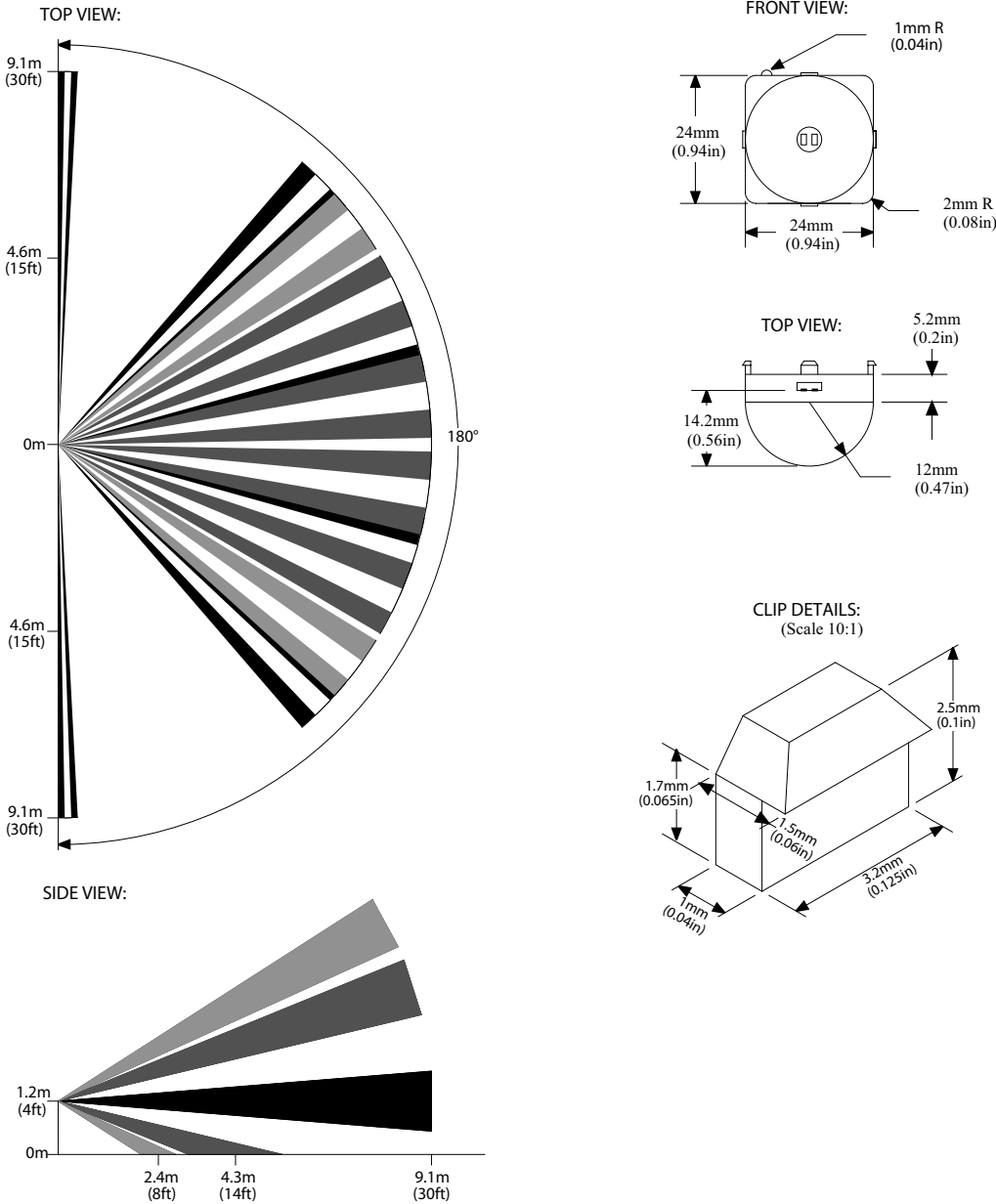

Figure 9. The ZCWM05GIV1 Lens Specification: Wall Mount

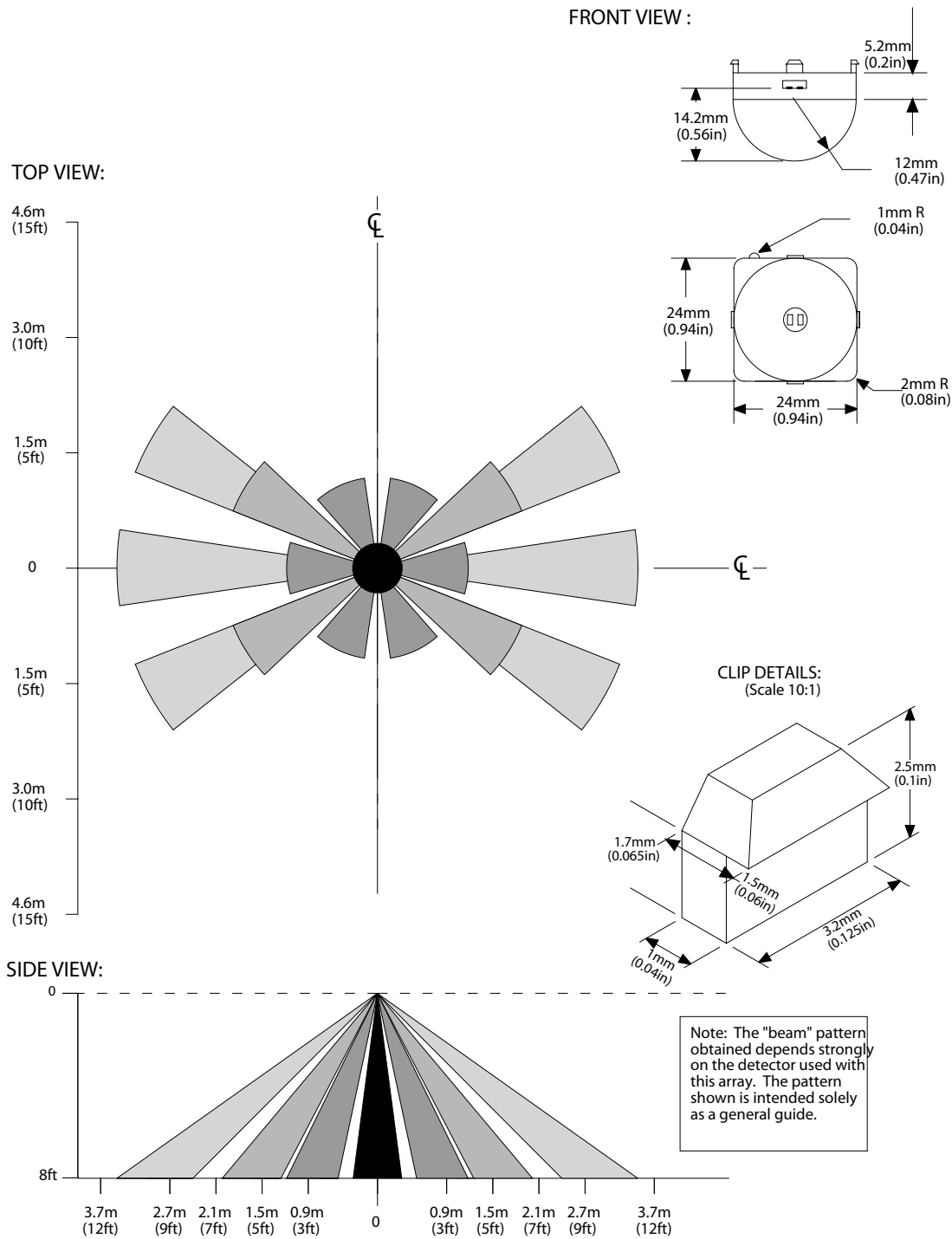
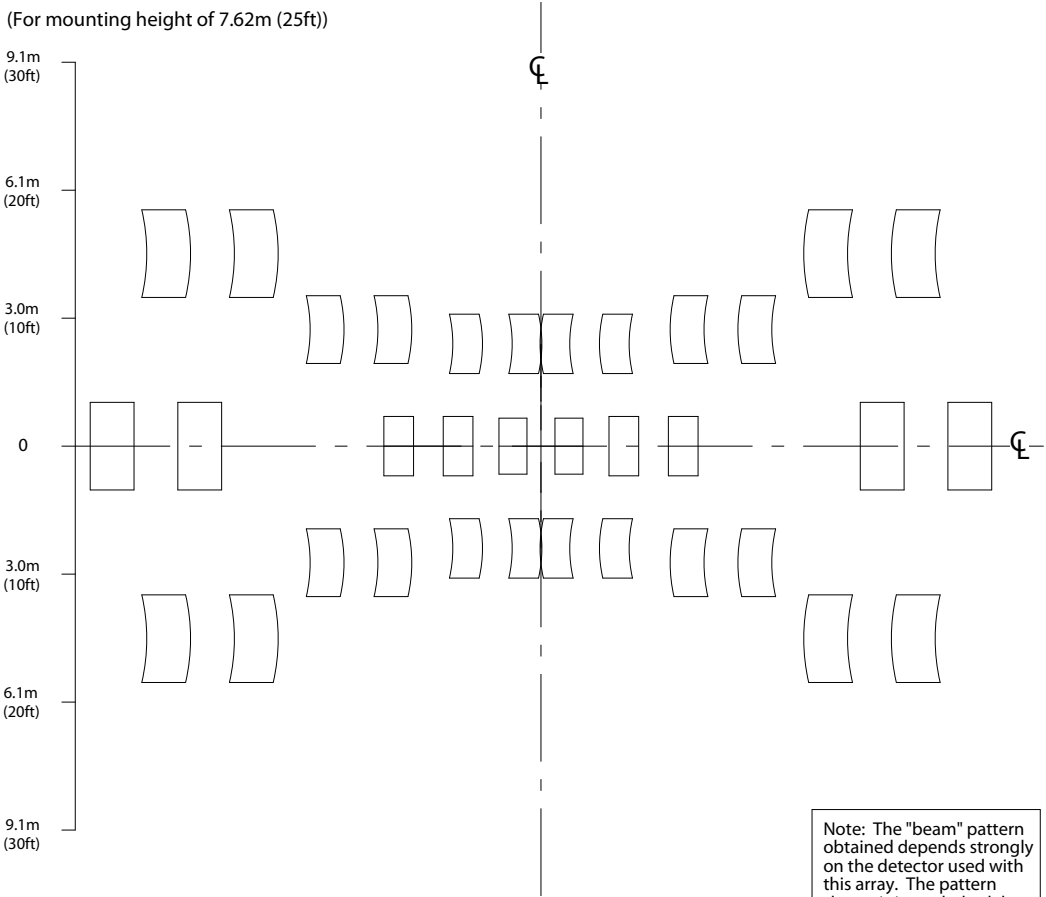

Figure 10. The ZCWM05GIV1 Lens Specification: Ceiling Mount, #1 of 2

FLOOR
COVERAGE:

(For mounting height of 7.62m (25ft))



SIDE VIEW:

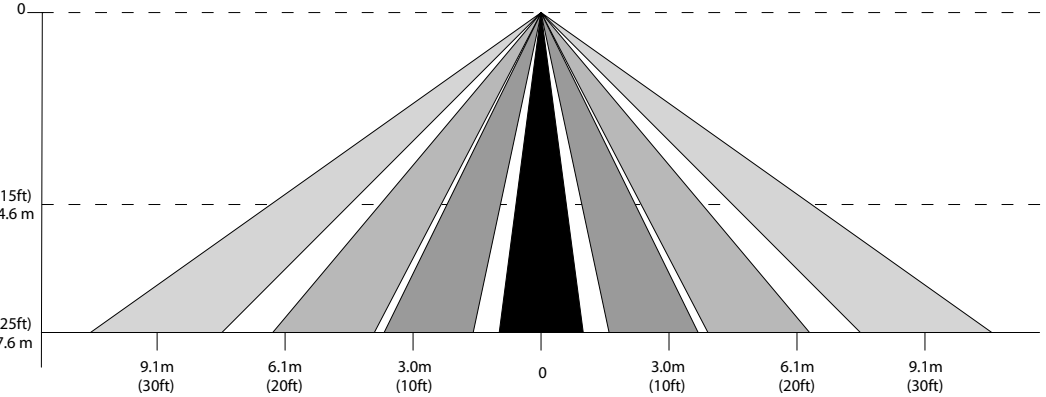

Figure 11. The ZCWM05GIV1 Lens Specification: Ceiling Mount, #2 of 2

ZEWA03GIV2 Lens Specification

The ZEWA03GIV2 lens is intended for wall-mounted room occupancy and proximity sensing applications in which an extra-wide sensing angle is required. See Figure 12.

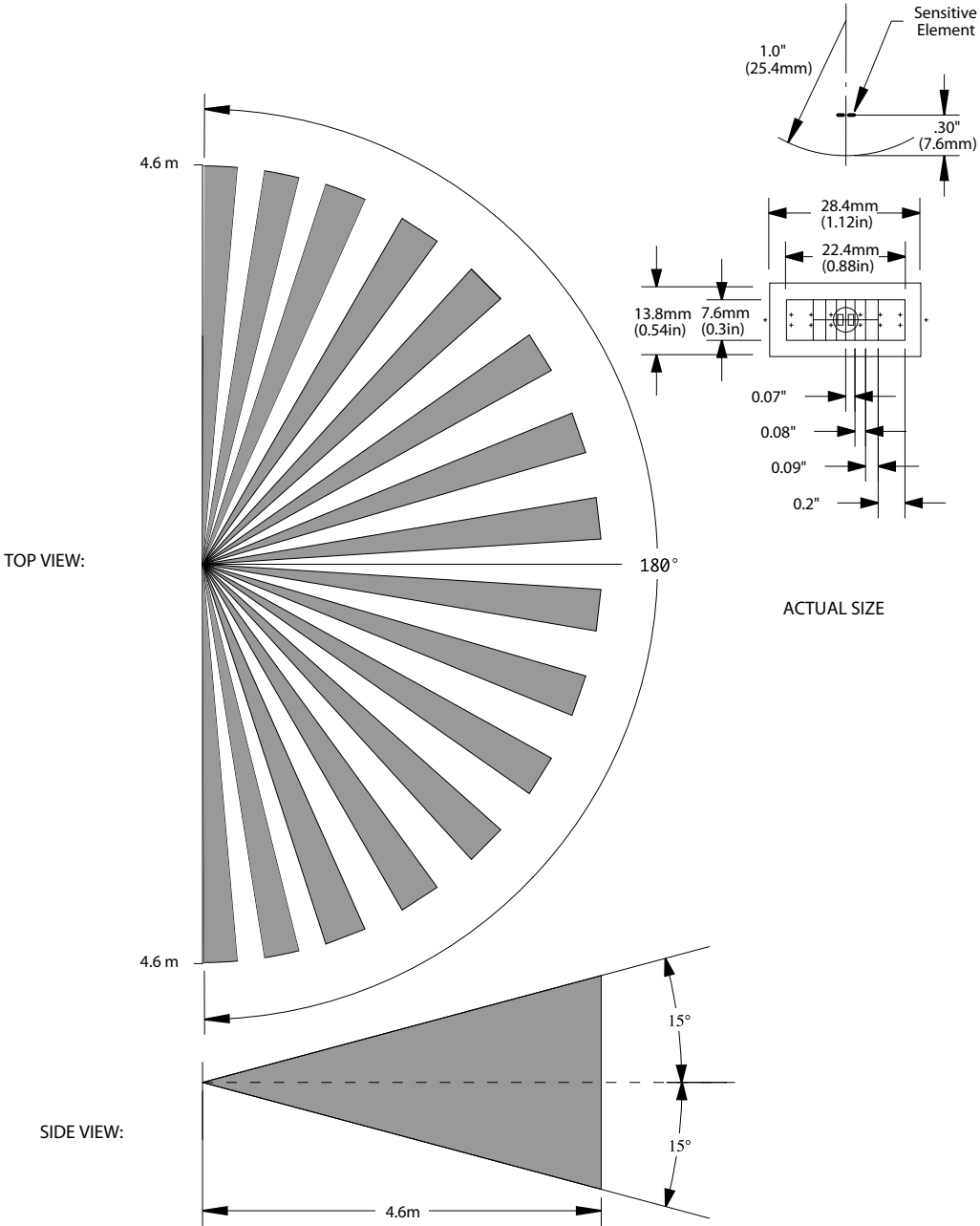

Figure 12. The ZEWA03GIV2 Lens Specification, Dimensions

ZNCL3B Lens Specification

The ZNCL3B lens is intended for wall-mounted entrance and proximity-sensing applications.

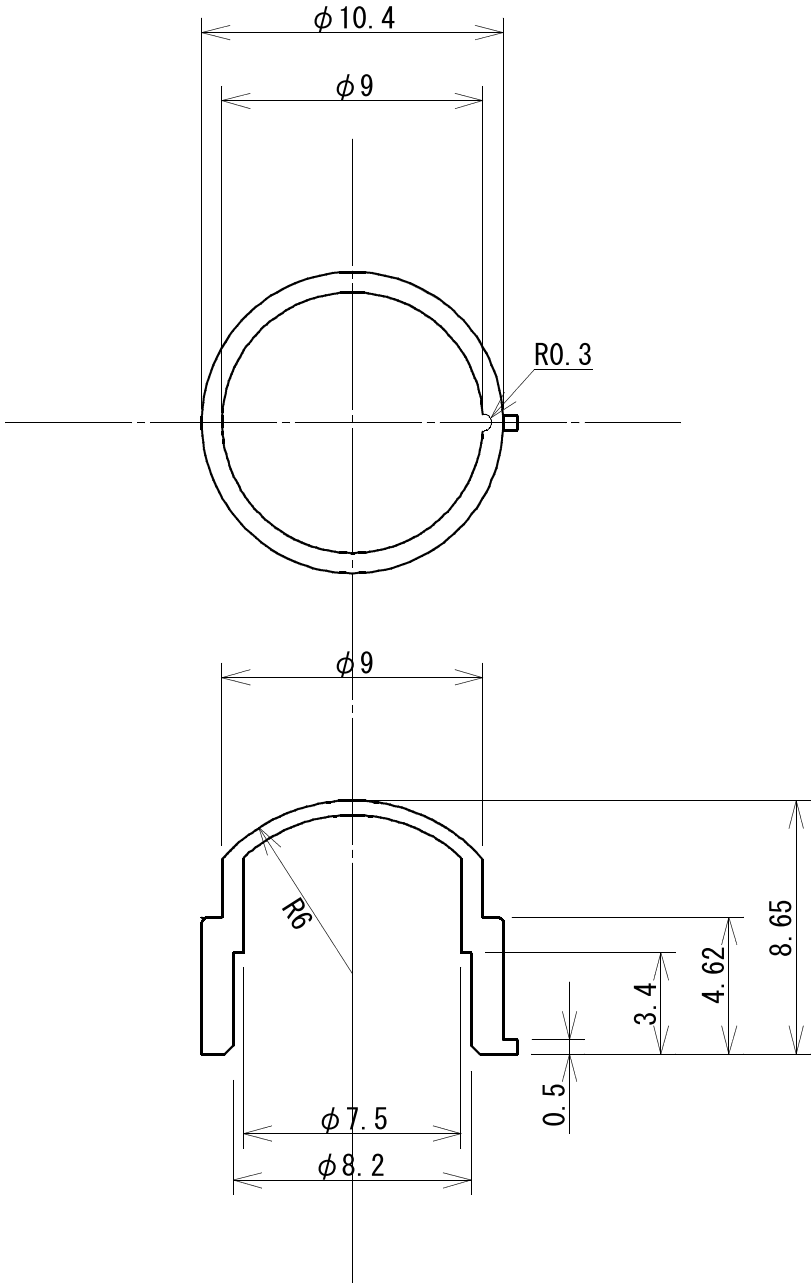

Figure 13. The ZNCL3B Lens Dimensions

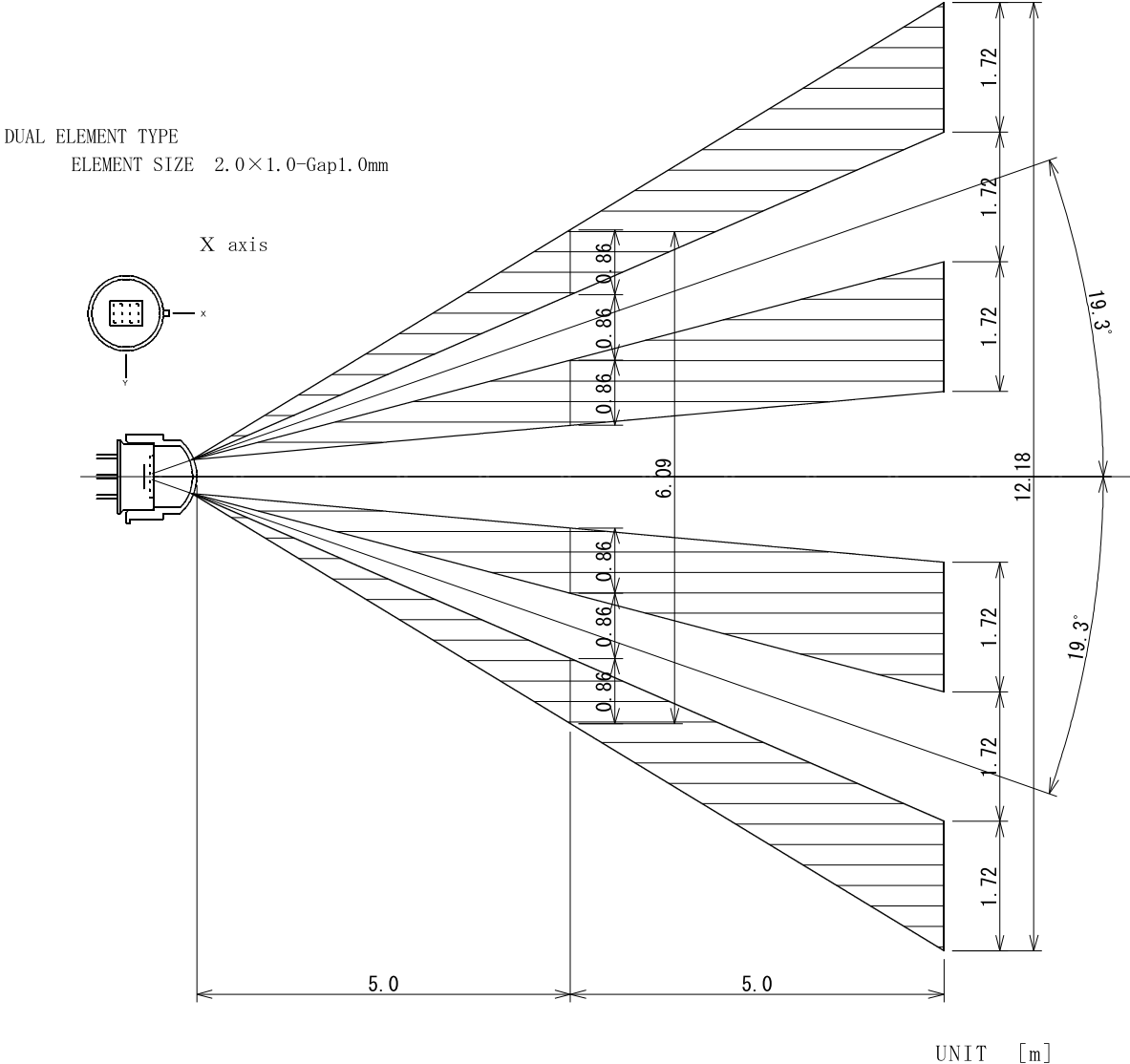

Figure 14. The ZNCL3B Lens Specification, X Axis

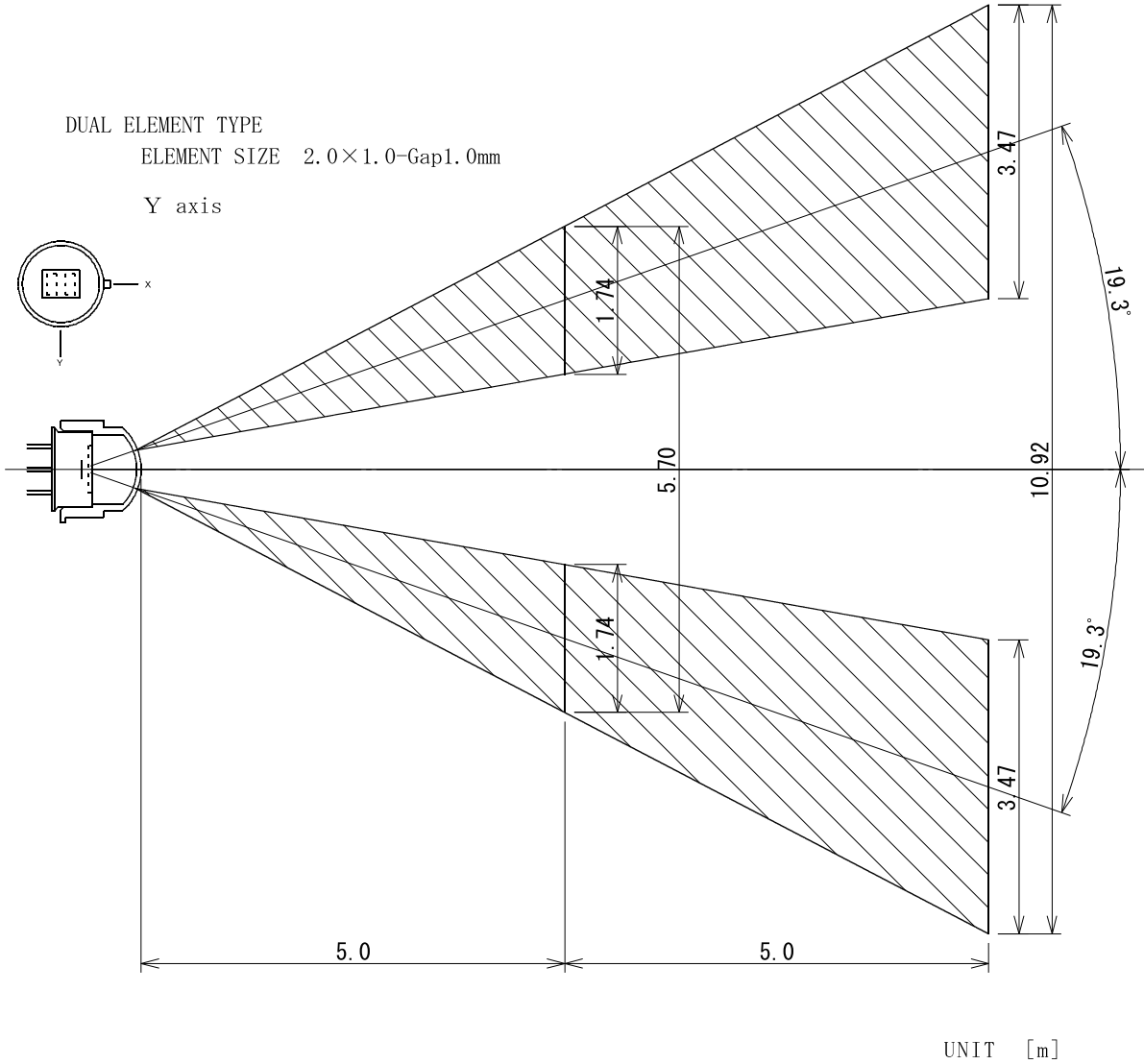

Figure 15. The ZNCL3B Lens Specification, Y Axis

ZNCL10R Lens Specification

The ZNCL10R lens is intended for ceiling-mounted entrance and proximity-sensing applications. This lens features two orientations, Tab A and Tab B, that can be used with the pyroelectric sensor to provide different beam patterns. Figures 16 through 19.

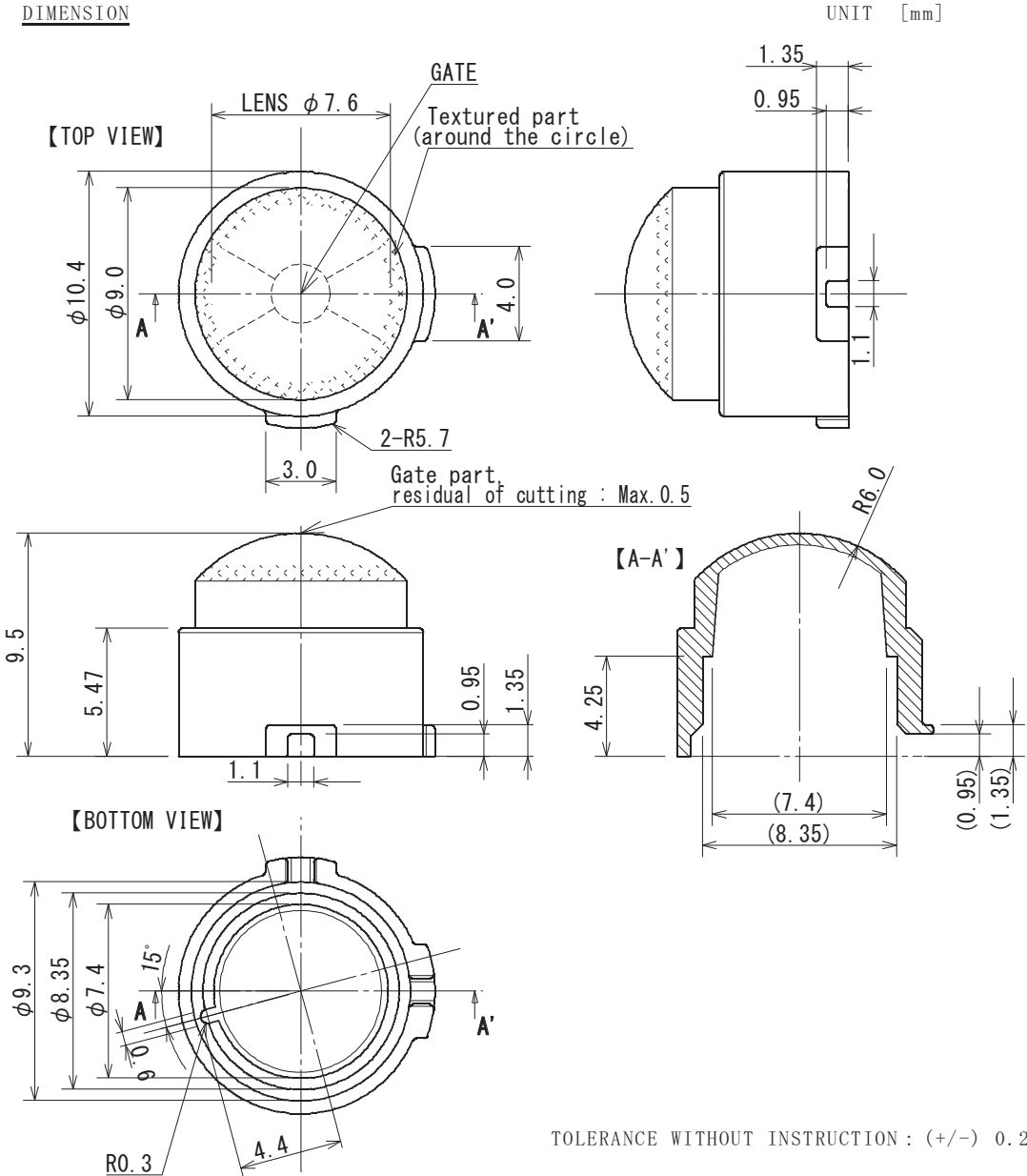

Figure 16. The ZNCL10R Lens Specification, Dimensions

FIELD OF VIEW (*)DUAL TYPE (ELEMENT SIZE 1.0 (X) × 2.0 (Y) × Gap1.0mm)

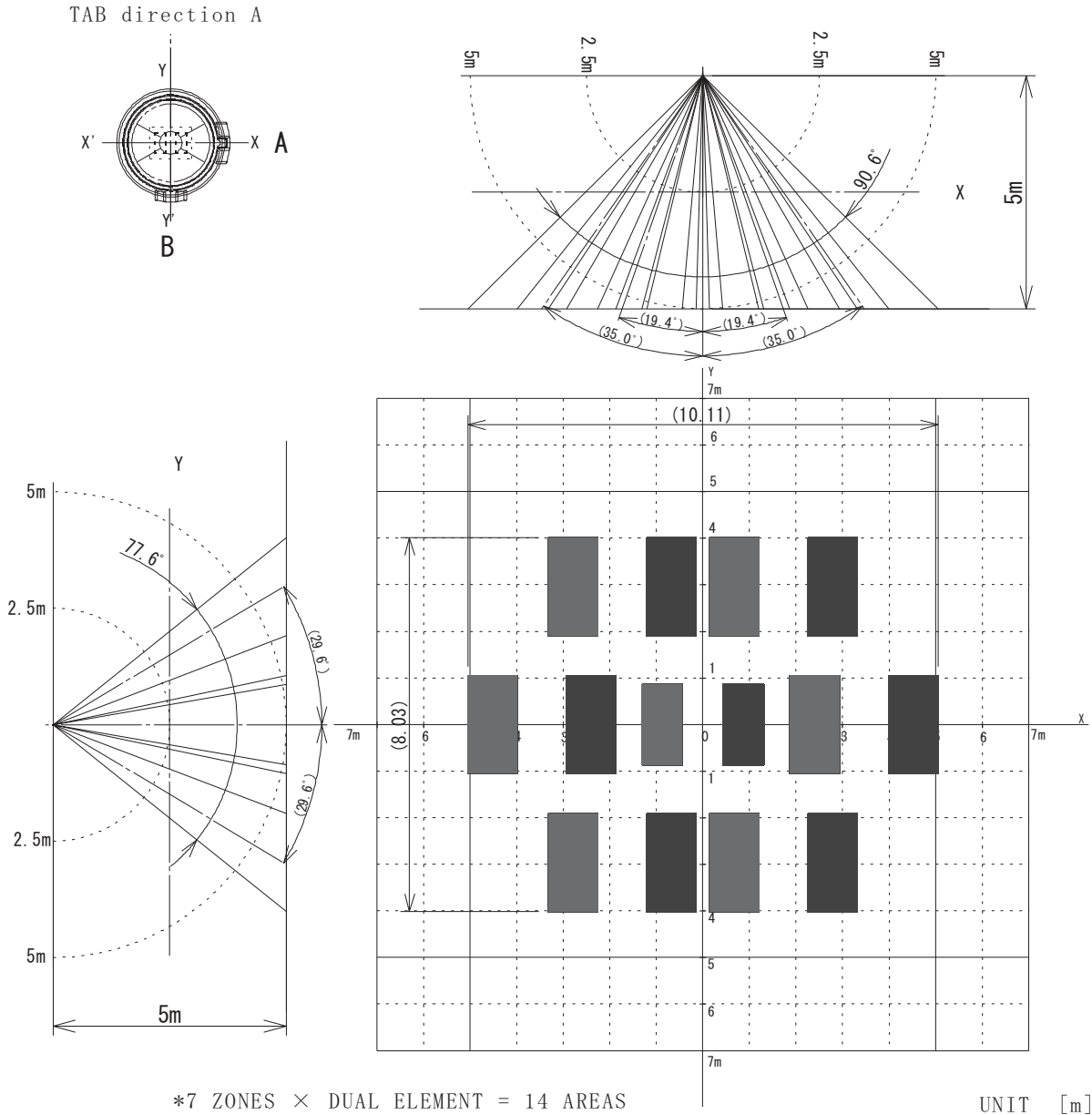

Figure 17. The ZNCL10R Dual-Element Lens Specification, Tab Direction A

FIELD OF VIEW (*)DUAL TYPE (ELEMENT SIZE 1.0(X) × 2.0(Y) × Gap1.0mm)

TAB direction B

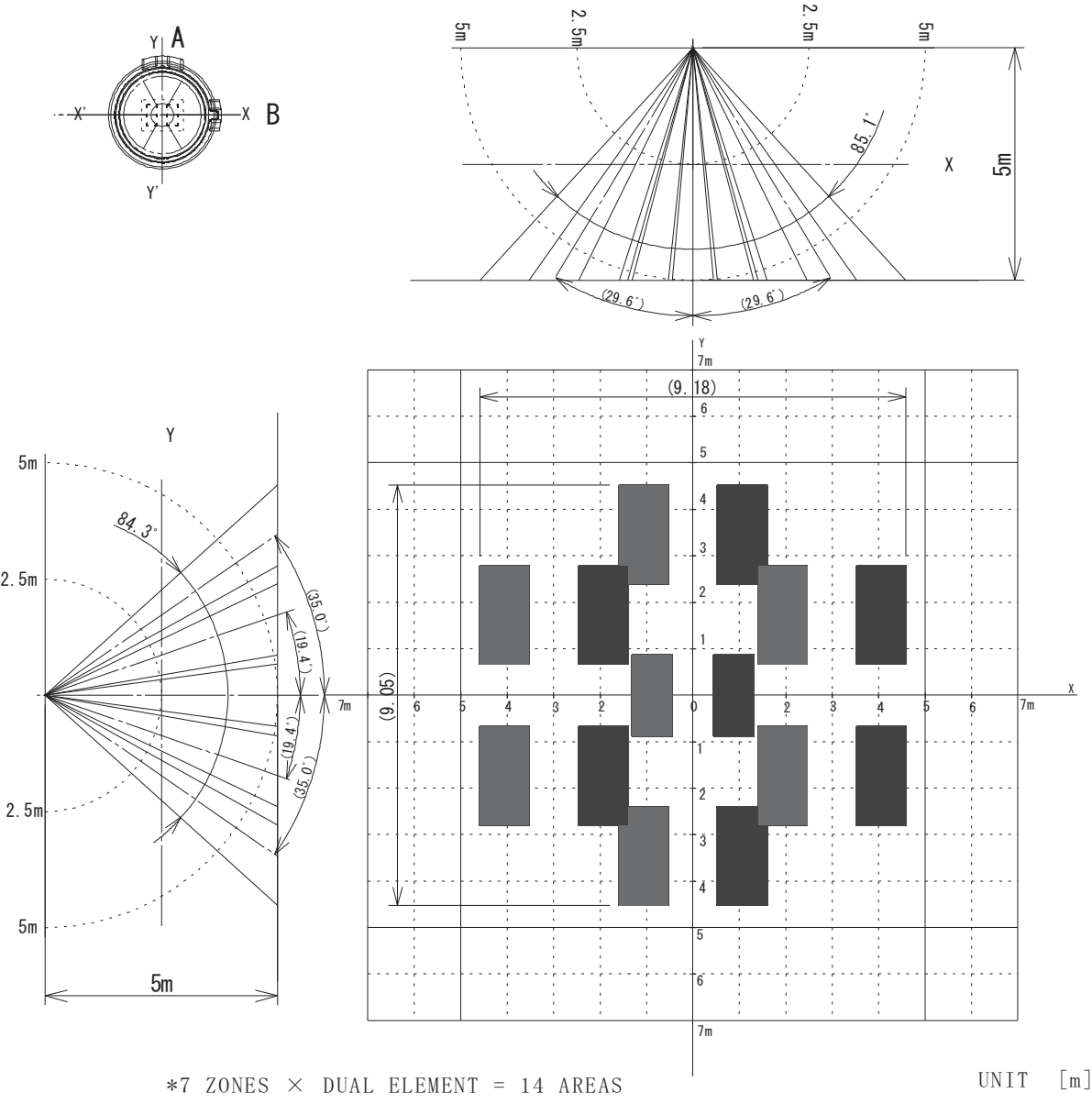

Figure 18. The ZNCL10R Dual-Element Lens Specification, Tab Direction B

FIELD OF VIEW (*) 4 ELEMENT TYPE (ELEMENT SIZE 1.0 × 1.0-Gap1.0mm)

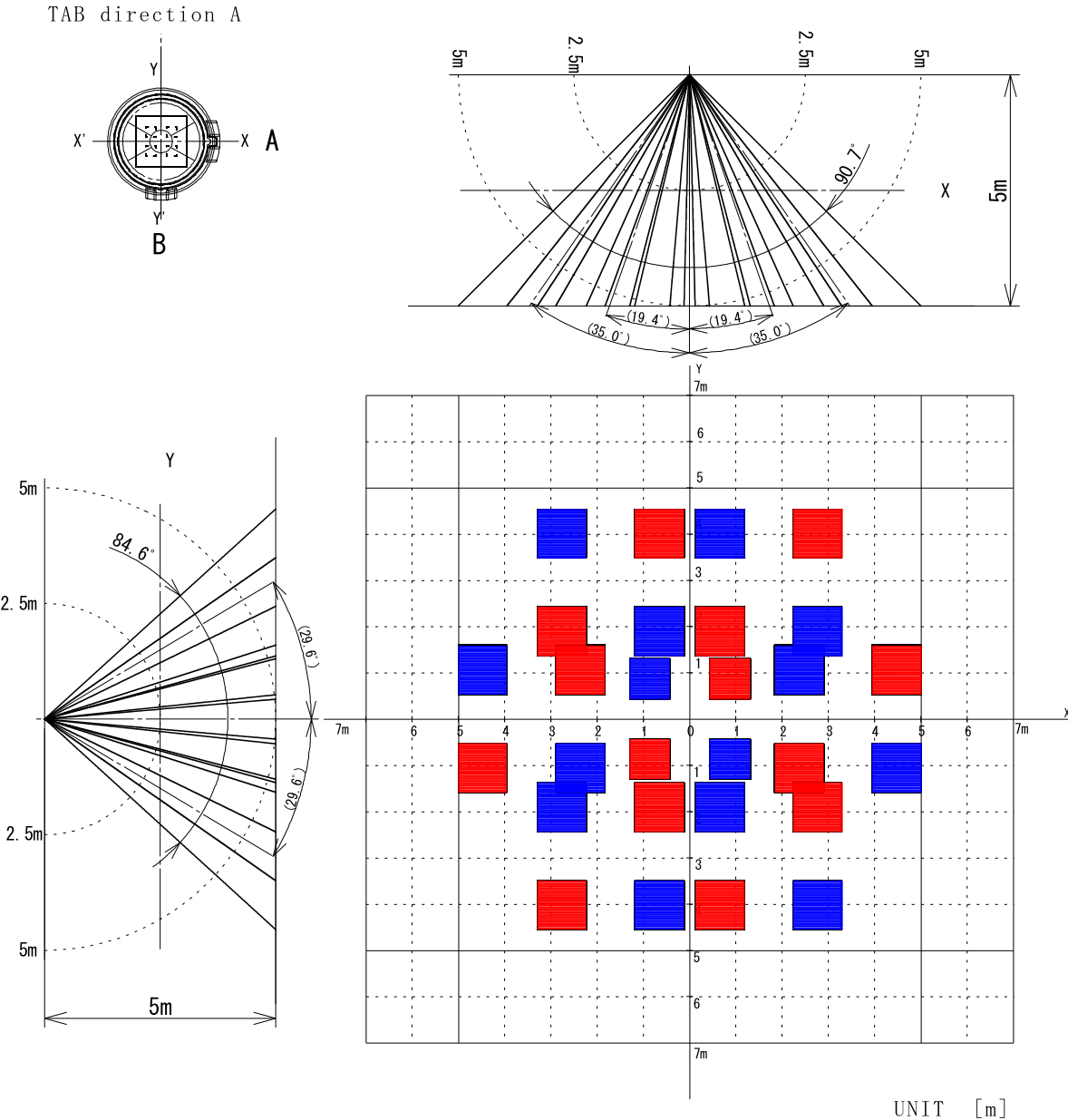

Figure 19. The ZNCL10R Quad-Element Lens Specification, Tab Direction A, X Axis

ZNCL926 Lens Specification

The ZNCL926 lens is intended for ceiling-mounted and other general purpose motion sensing applications. It is optimized for both dual and quad element pyroelectric sensors.

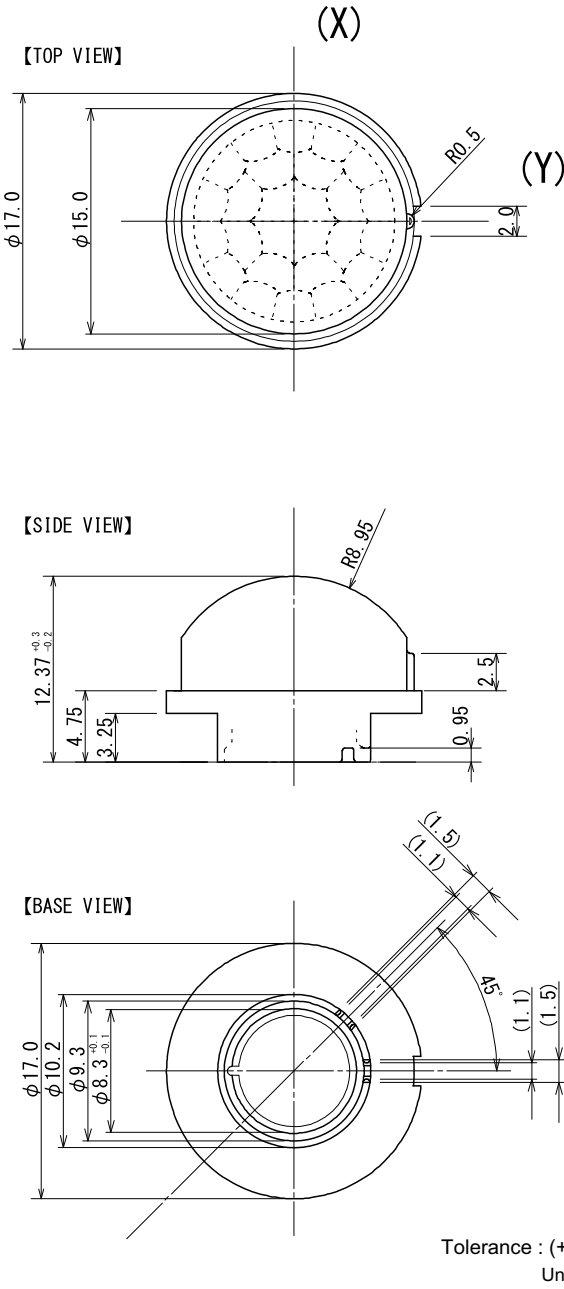
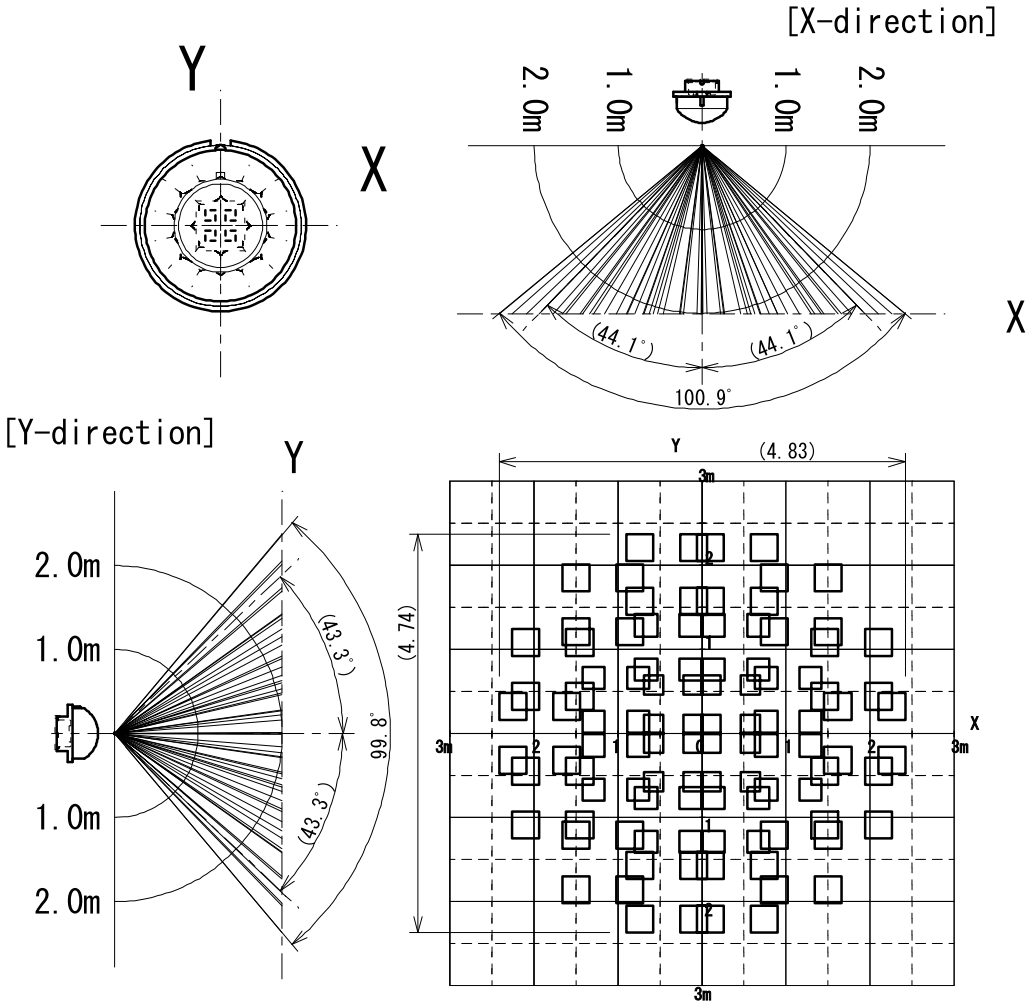
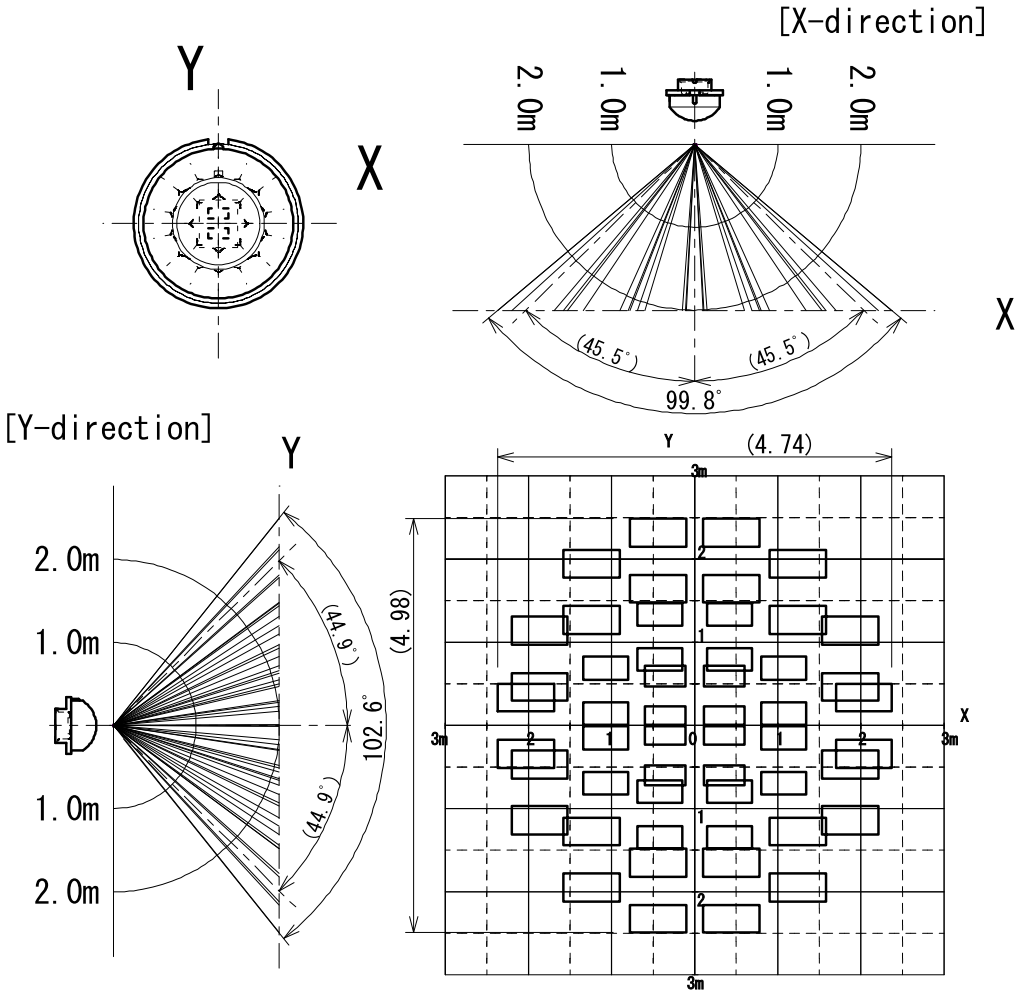

Figure 20. The ZNCL926 Lens Specification, Dimensions



- Sensor: Pyroelectric Infrared Sensor, 4 Element Type (one output)
 - Element Size: 1.0mm (X) x 1.0mm (Y) x Gap 1.0mm
- Unit [m]

Figure 21. The ZNCL926 Detection Area with Quad-Element PIR



- Sensor: Pyroelectric Infrared Sensor, Dual-Element Type
- Element Size: 2.0mm (X) x 1.0mm (Y) x Gap 1.0mm

Unit [m]

Figure 22. The ZNCL926 Detection Area with Dual-Element PIR

ZNCL10IL Lens Specification

The ZNCL10IL lens is intended for wall-mounted entrance and proximity-sensing applications. This lens features two orientations, Tab A and Tab B, that can be used with the pyroelectric sensor to provide different beam patterns. Refer to Figures 24 and 25 for the Tab A beam patterns and to Figures 26 and 27 for the Tab B beam patterns.

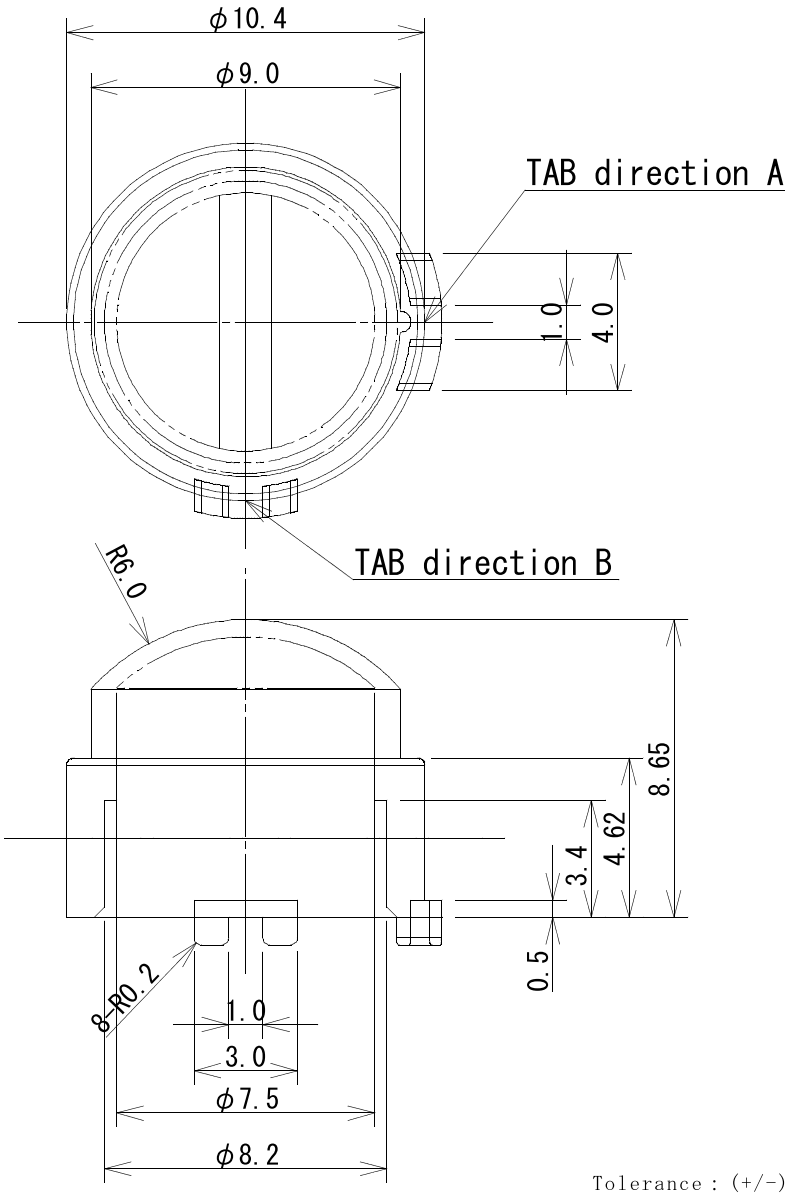

Figure 23. The ZNCL10IL Lens Specification, Dimensions

DUAL ELEMENT TYPE
 ELEMENT SIZE 2.0×1.0-Gap1.0mm
 TAB direction A
 X axis

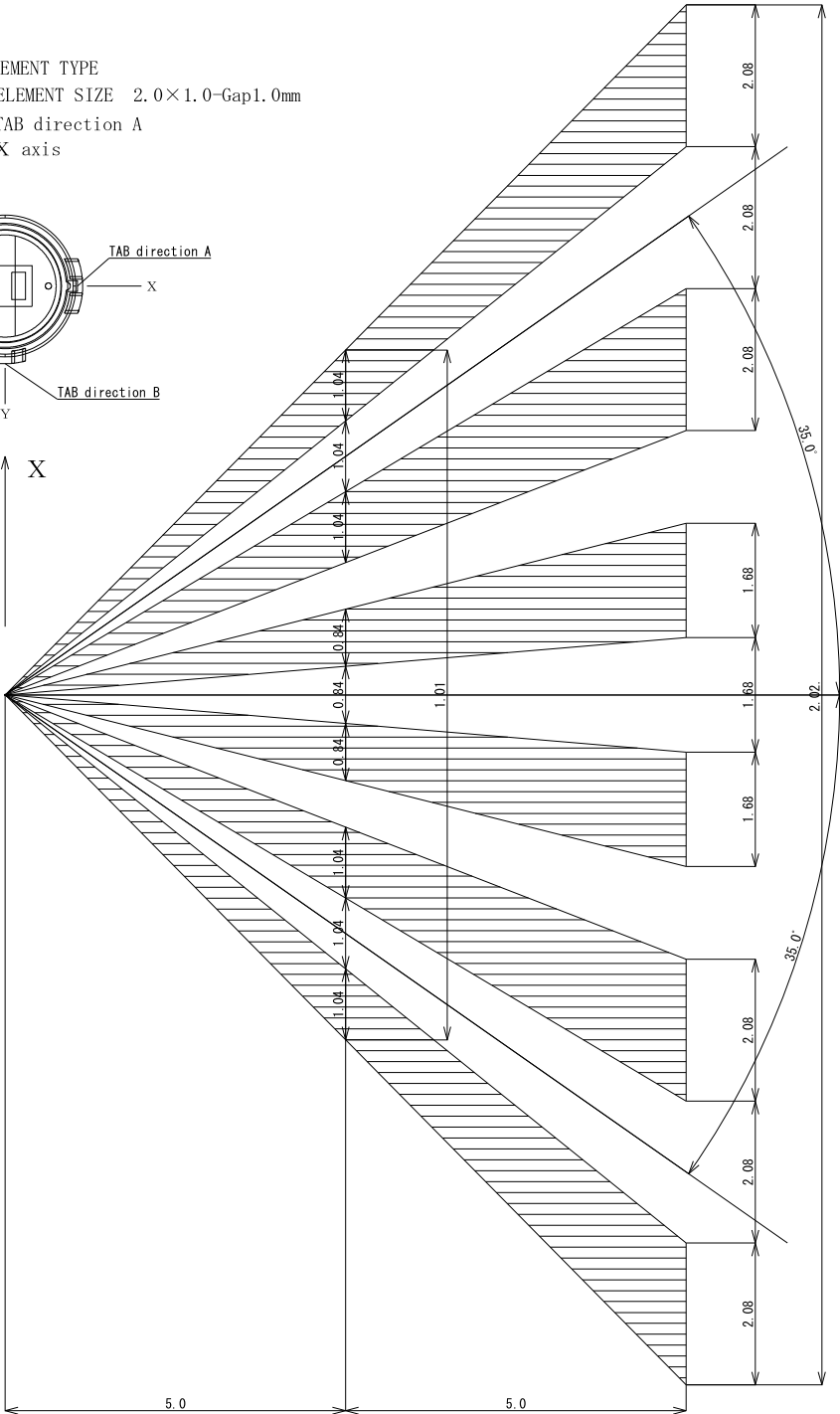
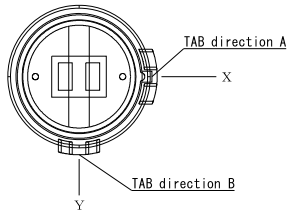

Figure 24. The ZNCL10IL Lens Specification, Tab Direction A, X Axis

FIELD OF VIEW

UNIT [m]

4 ELEMENT TYPE
ELEMENT SIZE 1.0×1.0-Gap1.0mm
TAB direction A
Y axis

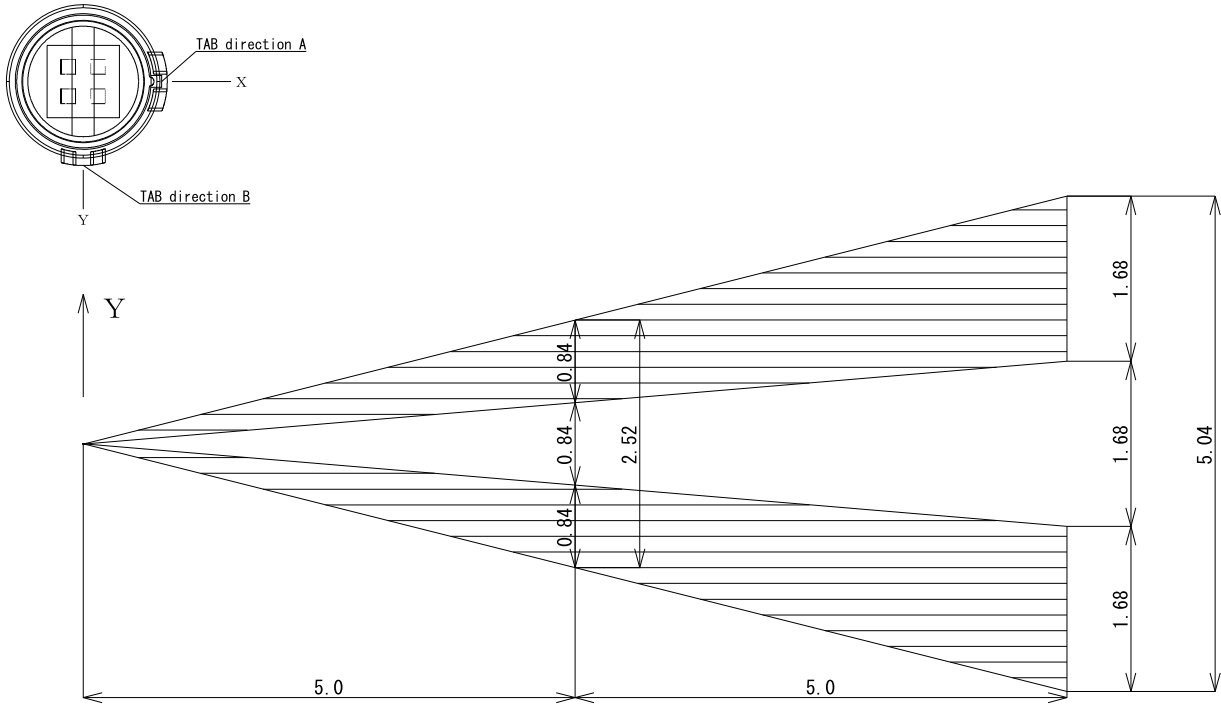

Figure 25. The ZNCL10IL Lens Specification, Tab Direction A, Y Axis

FIELD OF VIEW

UNIT [m]

4 ELEMENT TYPE
ELEMENT SIZE 1.0×1.0-Gap1.0mm
TAB direction B
X axis

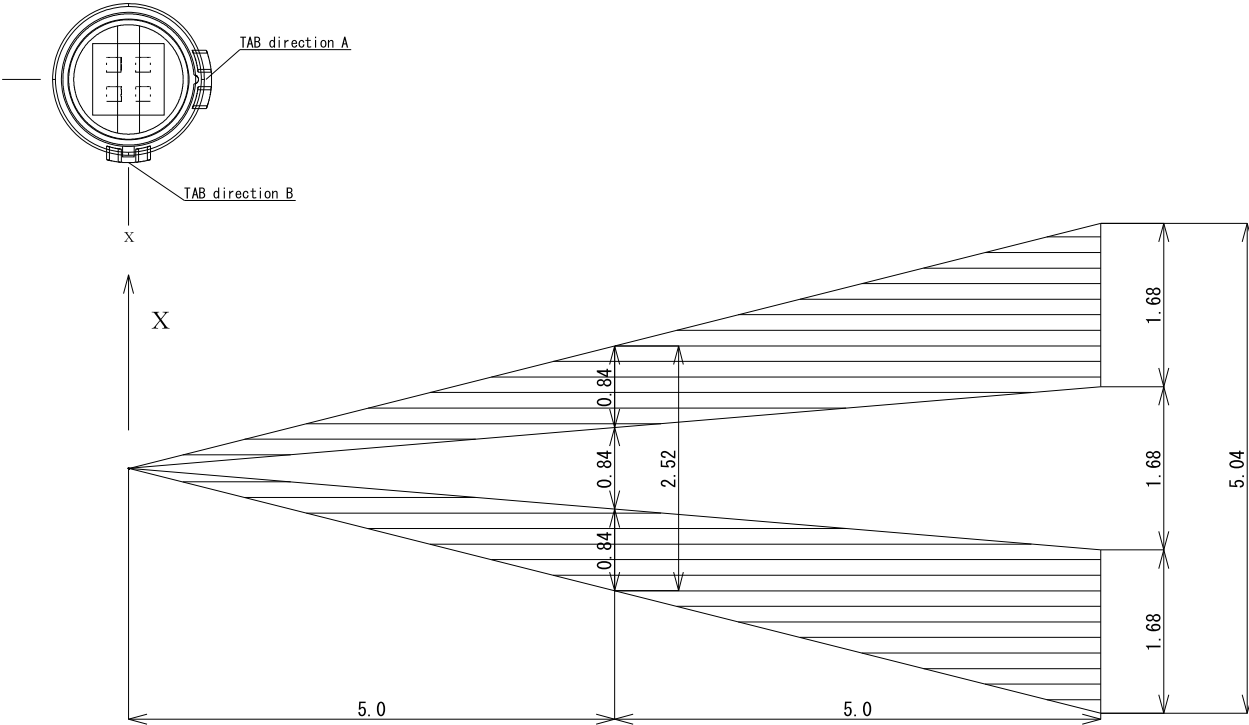

Figure 26. The ZNCL10IL Lens Specification, Tab Direction B, X Axis

FIELD OF VIEW

UNIT [m]

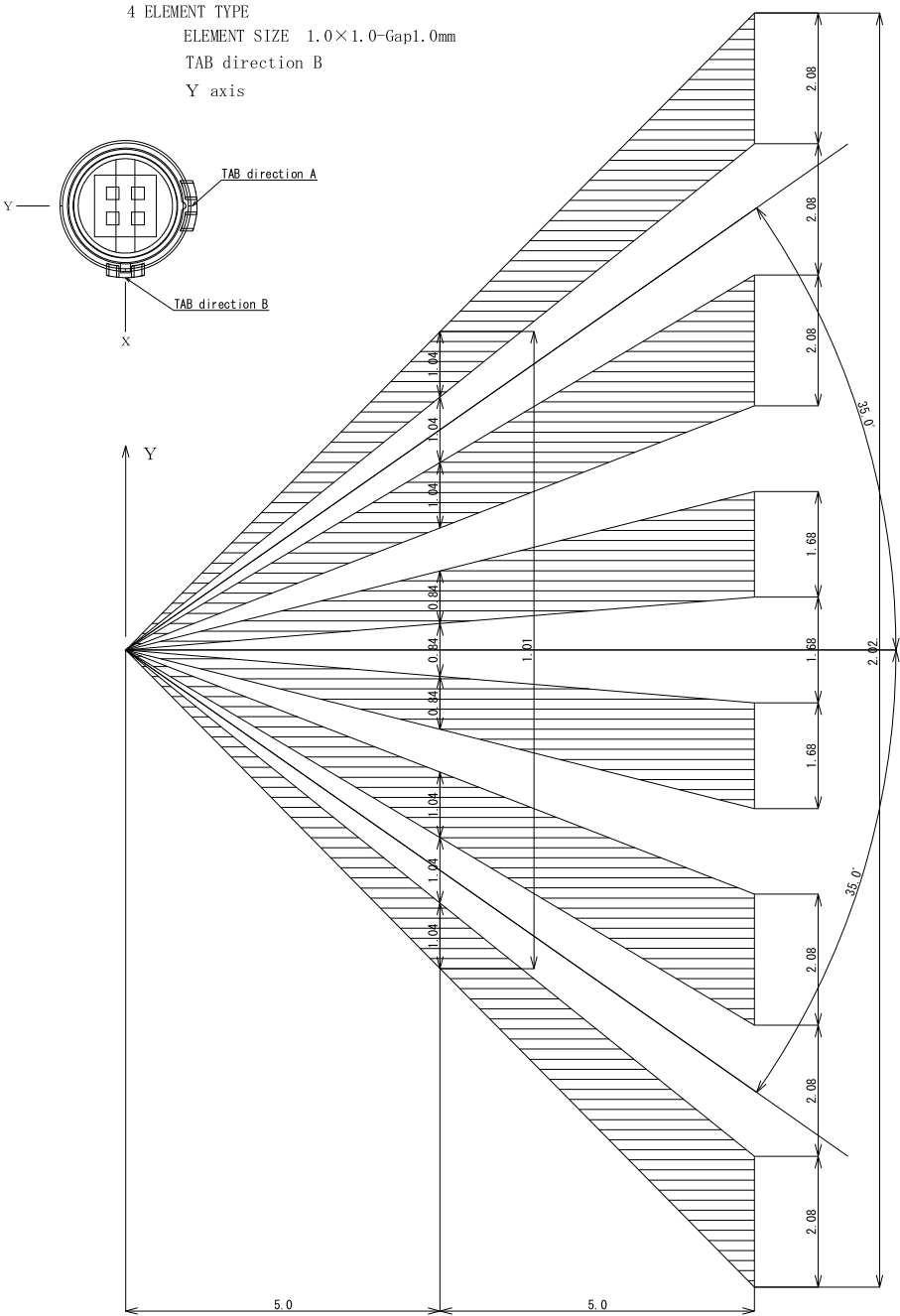

Figure 27. The ZNCL10IL Lens Specification, Tab Direction B, Y Axis

ZNCL10S Lens Specification

The ZNCL10S lens is intended for wall-mounted entrance detection applications wherein directional recognition is required. See Figures 28 and 29.

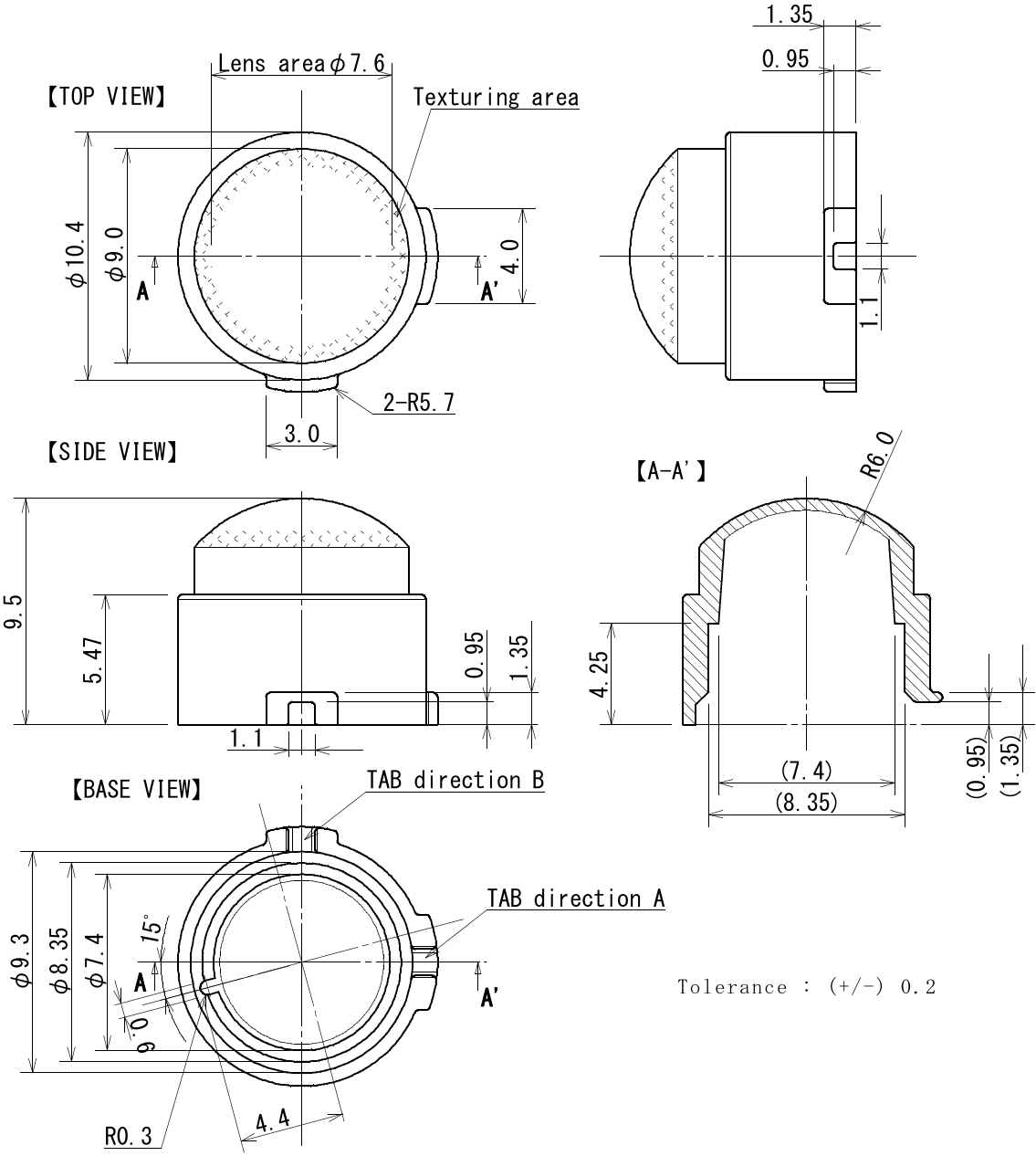

Figure 28. The ZNCL10S Lens Specification, Dimensions

FIELD OF VIEW

SINGLE ELEMENT TYPE
ELEMENT SIZE ϕ 1.75mm
X, Y axis

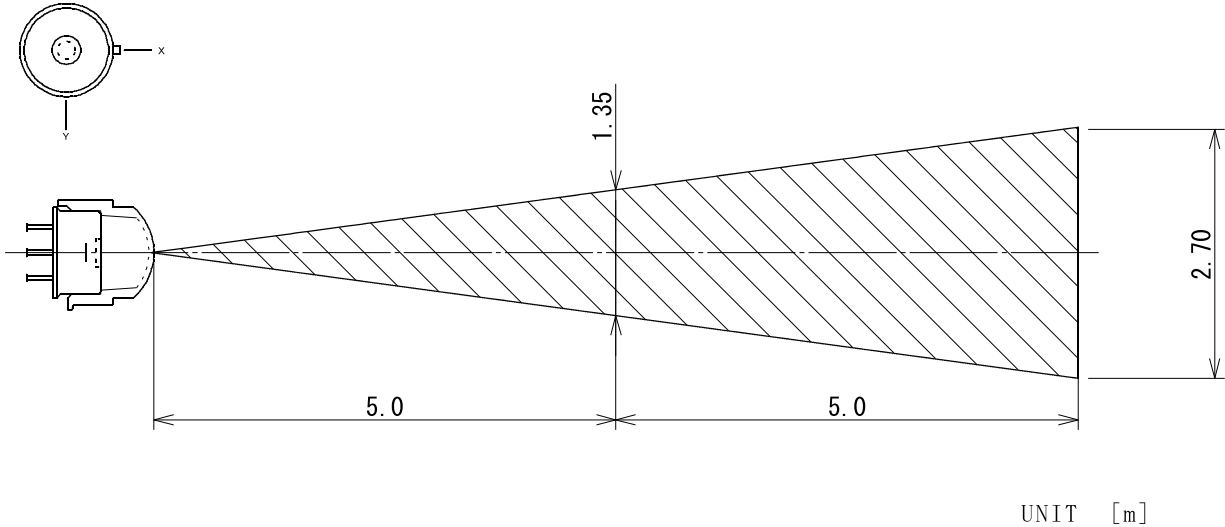

Figure 29. The ZNCL10S Dual-Element Lens Specification, X/Y Axes

ZNCL11 Lens Specification

The ZNCL11 lens is intended for wall-mounted room occupancy and proximity sensing applications with 32 detection zones. See Figures 30 and 31.

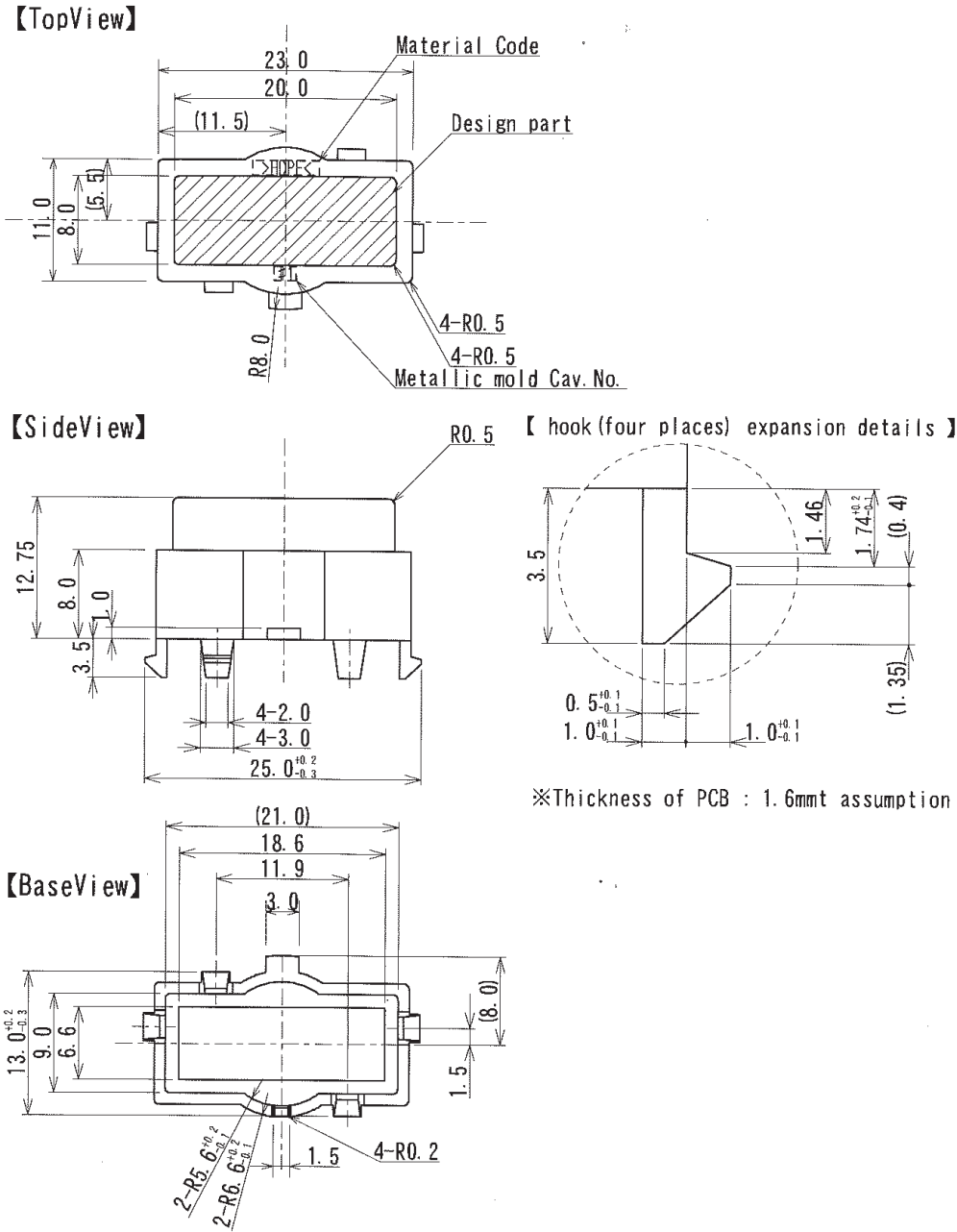
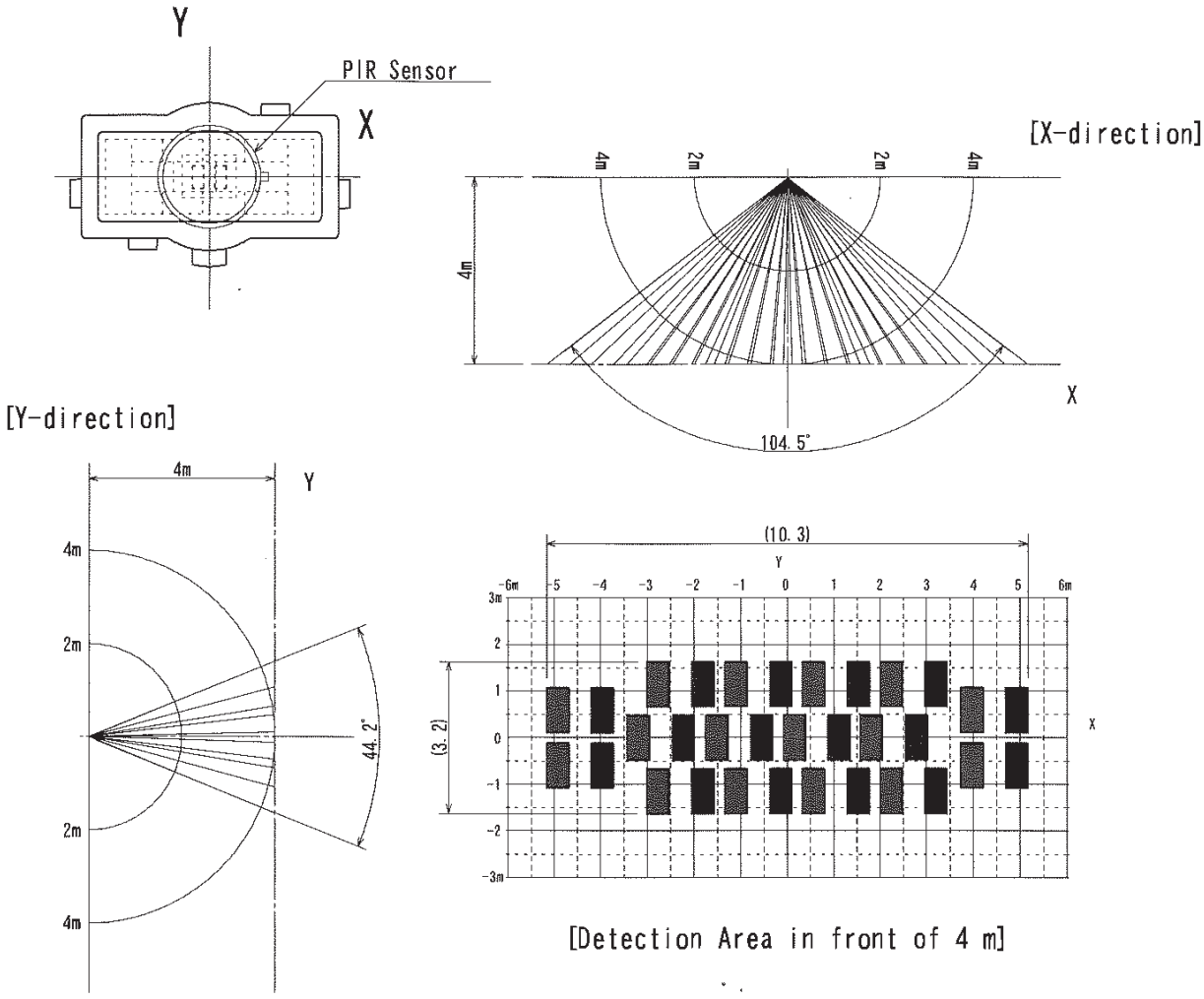

Figure 30. The ZNCL11 Lens Specification, Dimensions



[Detection Area in front of 4 m]

Unit [m]

*16 zones × dual element = 32 areas

- Sensor: Pyro-electric Infrared Sensor, Dual Element Type
- Element Size: 1.0mm (X) x 2.0mm (Y) x Gap1.0mm

Figure 31. The ZNCL11 Detection Area, X/Y Axes

ZMOTION Intrusion Detection Lens Specifications

Figures 32 through 34 provide the zone patterns and mechanical dimensions for the ZMOTION Intrusion Detection family of products. Recommended placement of the pyroelectric sensor is provided with the detector and lens inclined downward at an angle of 12 degrees. If you wish to use a tilt angle other than 12 degrees while maintaining the specified zone patterns, move the pyroelectric sensor up by 0.021" (0.53 mm) for each degree less than 12 degrees, or down by the same amount for each degree greater than 12 degrees.

The ZLR12GI12V3, ZVB12GIV1, and ZWA12GI12V4 lenses can be interchanged in the same end product without modifications to the placement or angle of the lens.

These lenses may also be used in nonintrusion applications. For additional lenses that do not require security/intrusion detection capabilities, refer to the [ZMOTION Detection and Control Lens Specifications](#) section on page 5.

ZLR12GI12V3 Lens Specification

The ZLR12GI12V3 lens array is optimized for dual-element pyroelectric sensors in long-range corridor security applications. It is normally used with the grooved side facing the pyroelectric detector, and curved at a 1.2 inch (30.5 mm) radius about the sensitive area of the detector. The detector and the lens array should be inclined downward at an angle of 12 degrees. If you wish to use a tilt angle other than 12 degrees while maintaining the specified zone pattern, move the pyroelectric sensor up by 0.021" (0.53 mm) for each degree less than 12 degrees, or down by the same amount for each degree greater than 12 degrees. The detector position should be 0.812" (20.6 mm) below the upper edge, and centered left-to-right.

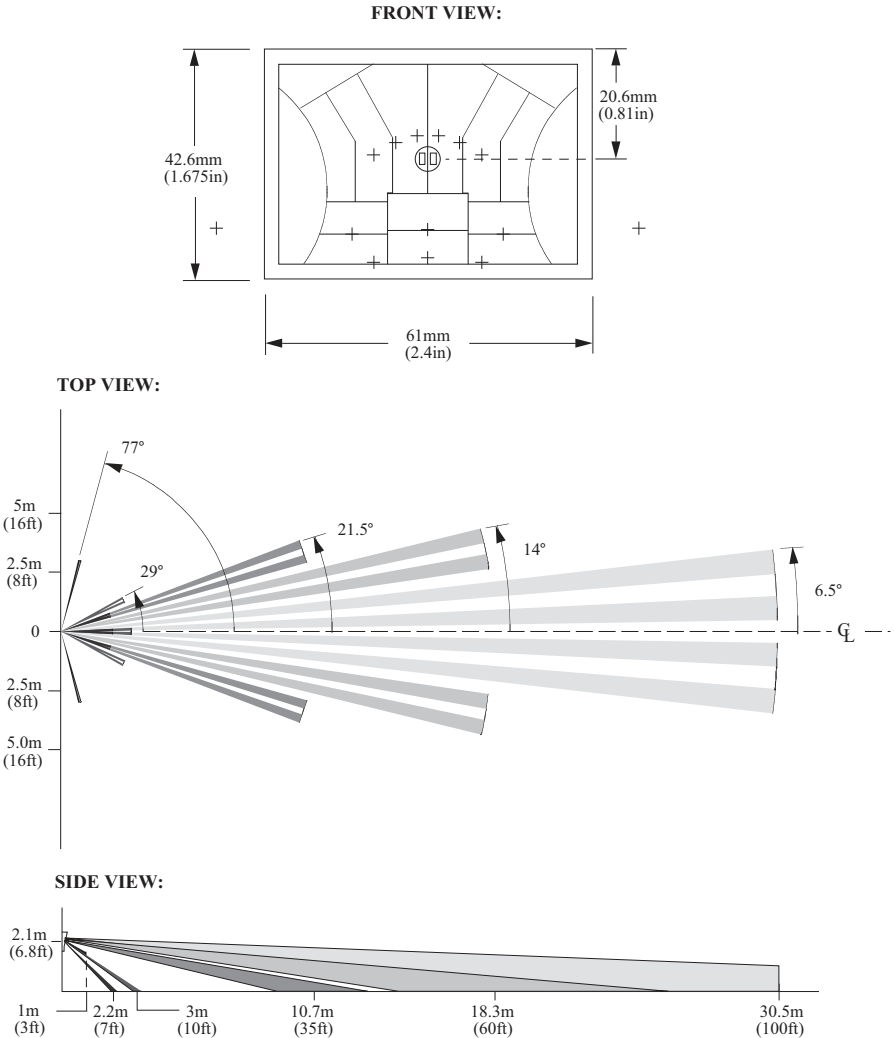

Figure 32. ZLR12GI12V3 Lens Specification

ZVB12GIV1 Lens Specification

The ZVB12GIV1 lens array is optimized for dual-element pyroelectric sensors in vertical barrier or curtain-type security applications. It is normally used with the grooved side facing the pyroelectric detector, and curved at a 1.2 inch (30.5 mm) radius about the sensitive area of the detector. The detector and the lens array should be inclined downward at an angle of 12 degrees. If you wish to use a tilt angle other than 12 degrees while maintaining the specified zone pattern, move the pyroelectric sensor up by 0.021" (0.53mm) for each degree less than 12 degrees, or down by the same amount for each degree greater than 12 degrees. The detector position should be 0.812" (20.6 mm) below the upper edge, and centered left-to-right.

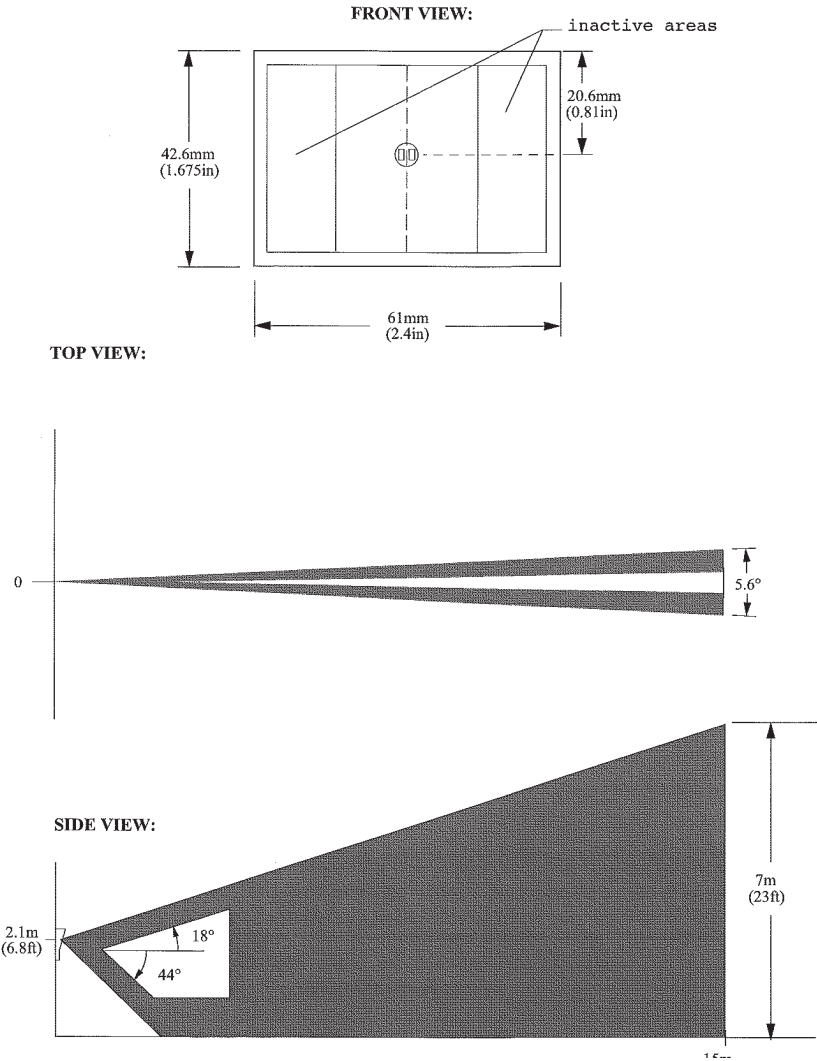

Figure 33. ZVB12GIV1 Lens Specification

ZWA12GI12V4 Lens Specification

The ZWA12GI12V4 lens array is optimized for dual-element pyroelectric sensors in large-area security applications. It is normally used with the grooved side facing the pyroelectric detector, and curved at a 1.2 inch (30.5mm) radius about the sensitive area of the detector. The detector and the lens array should be inclined downward at an angle of 12 degrees. If you wish to use a tilt angle other than 12 degrees while maintaining the specified zone pattern, move the pyroelectric sensor up by 0.021" (0.53 mm) for each degree less than 12 degrees, or down by the same amount for each degree greater than 12 degrees. The detector position should be 0.812" (20.6mm) below the upper edge, and centered left-to-right.

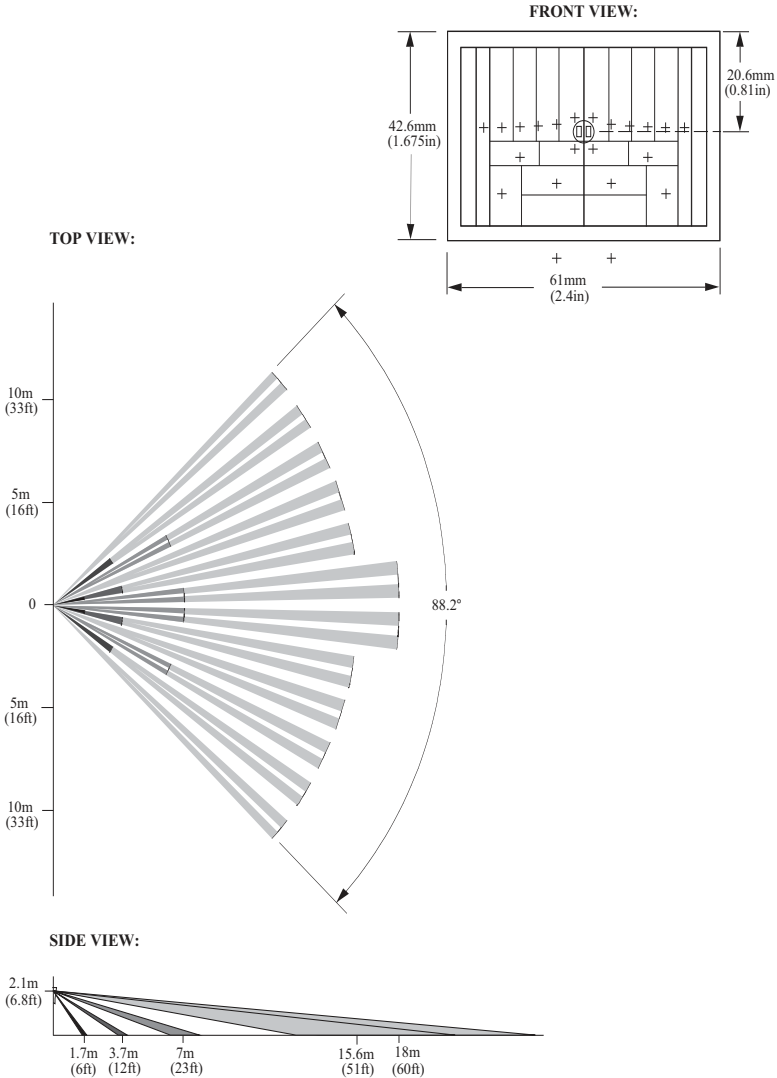

Figure 34. ZWA12GI12V4 Lens Specification

Related Documents

Additional information about the ZMOTION Families of Motion Detection MCUs can be found in the following documents, which are available from the Zilog website.

Document Number	Description
PB0225	ZMOTION Detection and Control Family Product Brief
PB0230	ZMOTION Intrusion Detection Product Brief
PS0228	Z8 Encore! XP® F082A Series Product Specification
PS0285	ZMOTION Detection and Control Family Product Specification
PS0288	ZMOTION Intrusion Detection Product Specification
PS0336	ZMOTION Pyroelectric Sensors Specification
AN0307	ZMOTION Detection Module Application Walkthrough
AN0309	ZMOTION High Brightness White LED Lighting Application Note
WP0017	A New PIR Motion Detection Architecture White Paper
WP0018	ZMOTION Detection Lens and Pyro Sensor Configuration Guide
Other ZMOTION Family Products	
PB0244	ZMOTION Detection Module II Product Brief
PS0305	ZMOTION Detection Module II Product Specification

Customer Support

To share comments, get your technical questions answered, or report issues you may be experiencing with our products, please visit Zilog's Technical Support page at <http://support.zilog.com>.

To learn more about this product, find additional documentation, or to discover other facets about Zilog product offerings, please visit the Zilog Knowledge Base at <http://zilog.com/kb> or consider participating in the Zilog Forum at <http://zilog.com/forum>.

This publication is subject to replacement by a later edition. To determine whether a later edition exists, please visit the Zilog website at <http://www.zilog.com>.