

| LOC | | DIST | | REVISIONS | | | |
|-----|-----|-----------------------|---------|-----------|------|--|--|
| P | LTR | DESCRIPTION | DATE | DMN | APVD | | |
| C | | REV PER ECO 15-005911 | 5-28-15 | CT | DM | | |

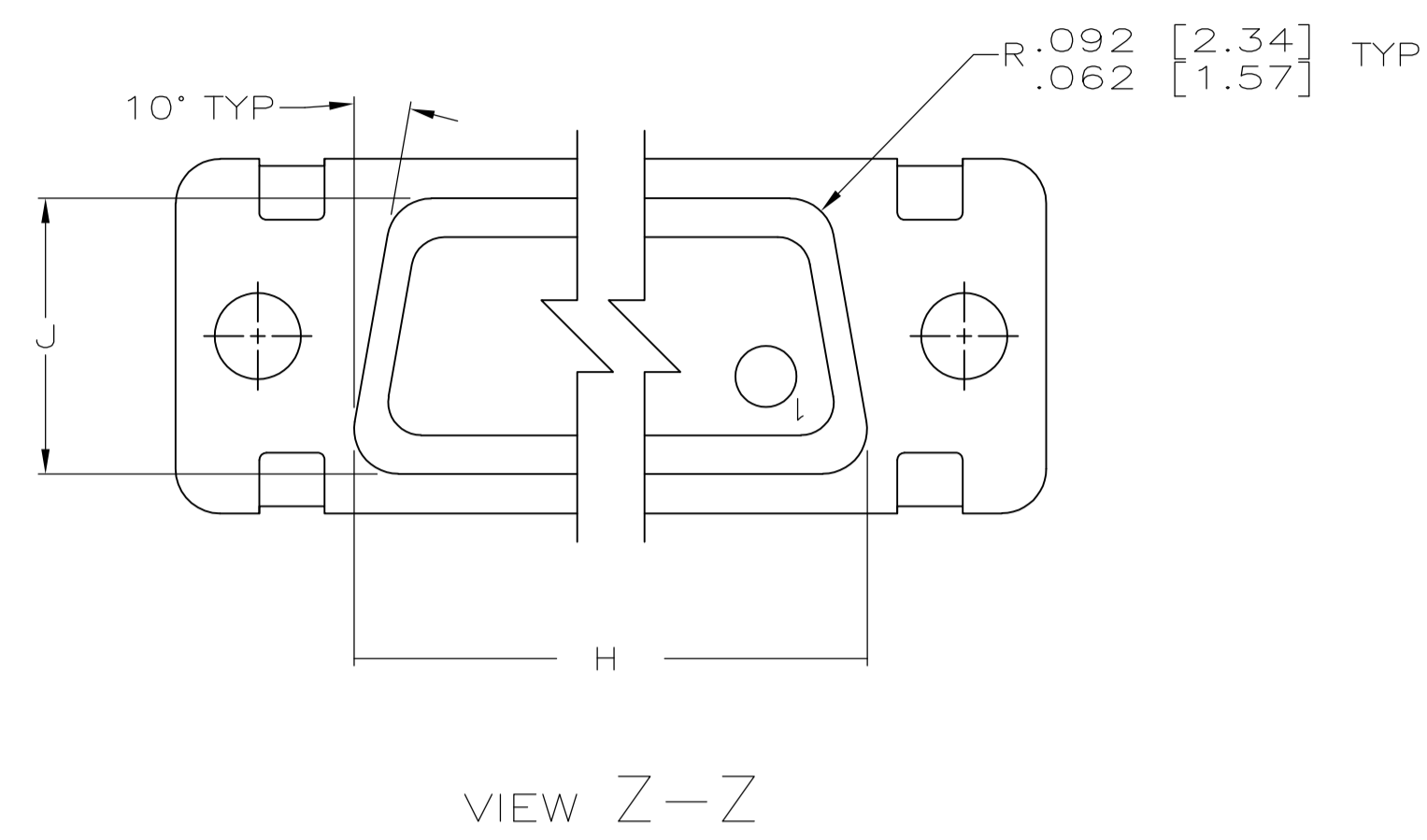

- THIS CONNECTOR ASSEMBLY IS SUPPLIED WITH METAL CONTACT RETENTION CLIPS INSTALLED IN THE INSERT ASSEMBLY.
- THIS CONNECTOR ASSEMBLY MEETS THE REQUIREMENTS OF MIL-C-24308 AND MATES WITH ANY PLUG CONNECTOR WITH SAME INSERT ARRANGEMENT.
- MARK WITH .047 [1.19]-.062 [1.57] HIGH CHARACTERS. FAR SIDE REFERS TO THE WIDE SIDE OF THE KEYSTONE. NEAR SIDE REFERS TO THE NARROW SIDE OF THE KEYSTONE. IF THE REAR SHELL IS TOO SMALL FOR THE ENTIRE MILITARY PART NUMBER, MARKING SHALL BE LOCATED AS FOLLOWS:
 - "M24308" ON FRONT SHELL, FAR SIDE.
 - SLASH SHEET AND DASH NUMBER ON REAR SHELL, FAR SIDE.
 - "AMP" AND DATE CODE ON FRONT SHELL, NEAR SIDE.
 - AMP PART NUMBER ON REAR SHELL, NEAR SIDE.
 IF THE FRONT SHELL IS TOO SMALL FOR "AMP", AMP PART NUMBER AND DATE CODE, THEN SPLIT AS FOLLOWS:
 - AMP PART NUMBER ON REAR SHELL, NEAR SIDE.
 - "AMP" AND DATE CODE ON FRONT SHELL, NEAR SIDE.
 - MILITARY PART NUMBER ON REAR SHELL, FAR SIDE.

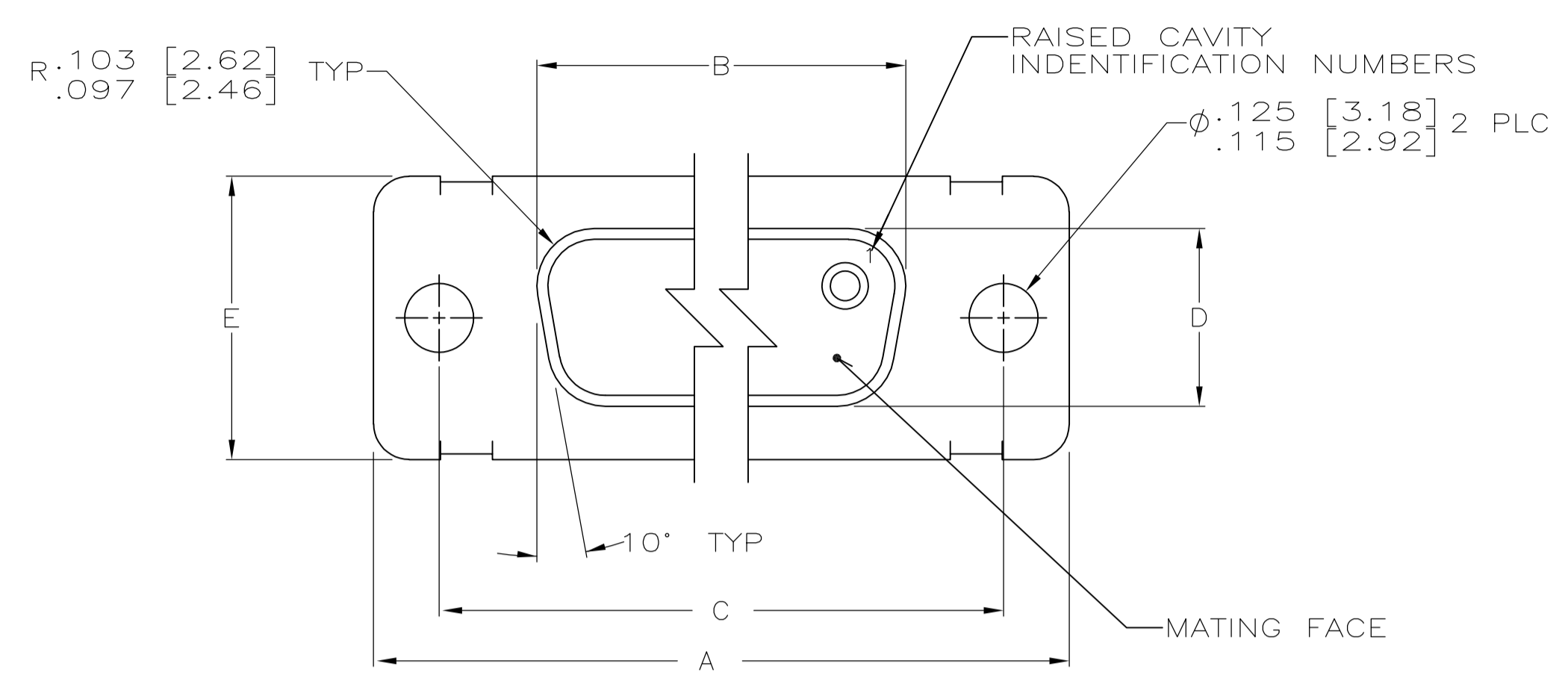
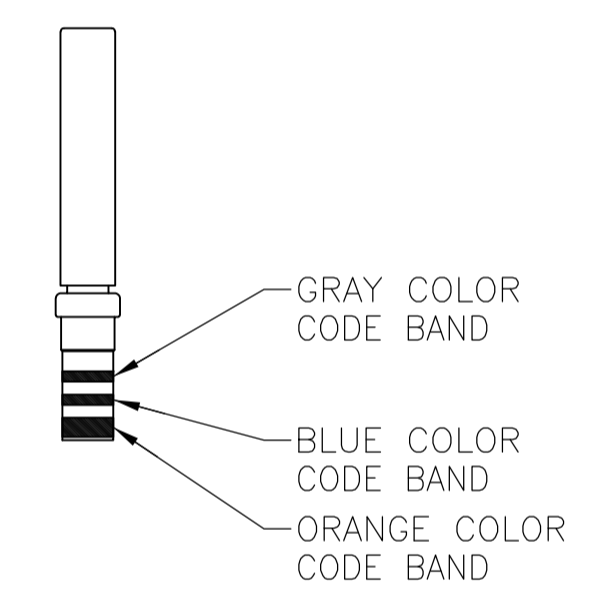
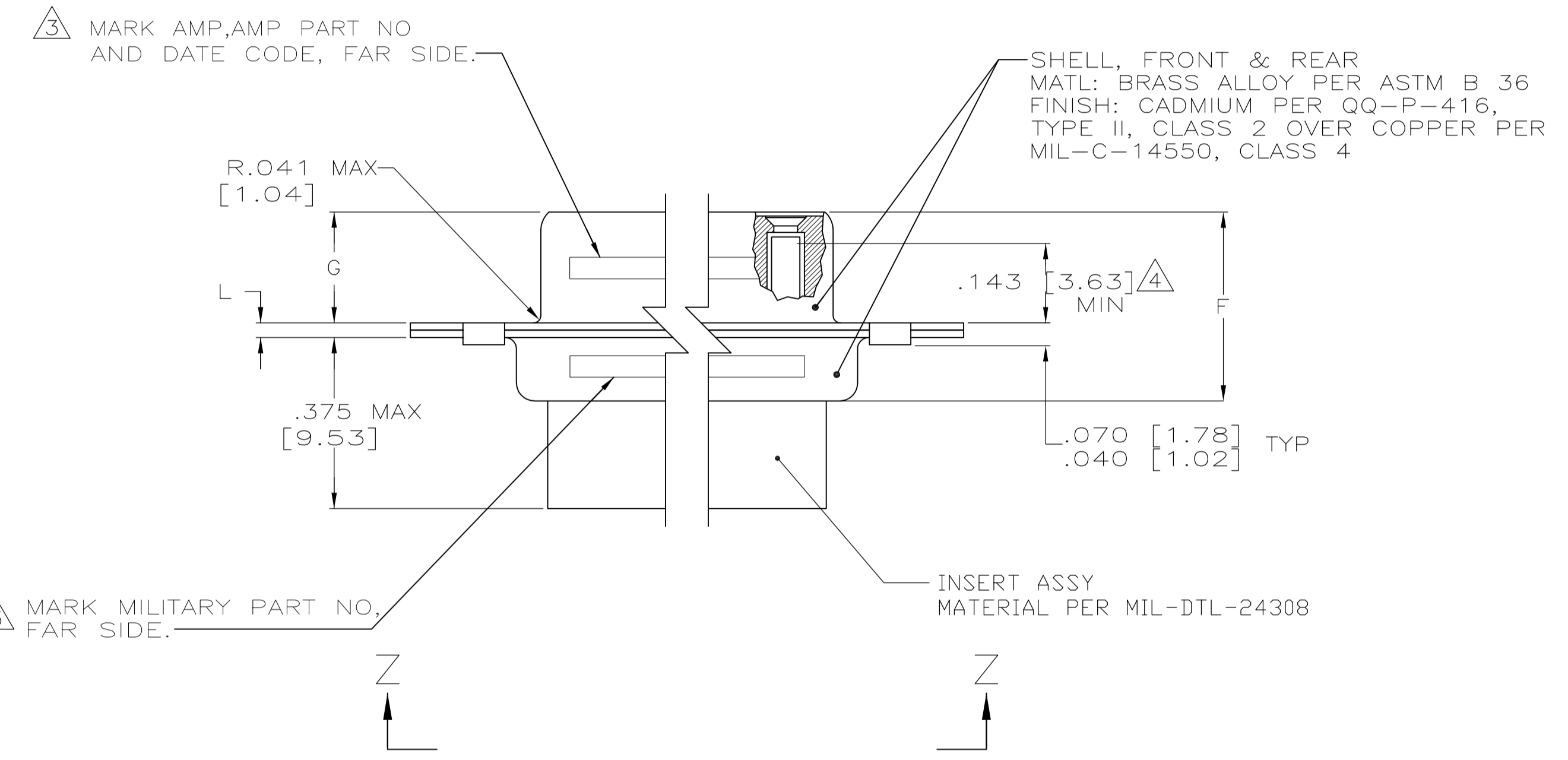

- POINT OF ELECTRICAL ENGAGEMENT - AS MEASURED WITH A .039 [0.99] - .041 [1.04] DIAMETER SQUARE ENDED TEST PIN. CONTACT SHOWN INSTALLED FOR DIMENSIONAL REFERENCE ONLY.
- MAXIMUM WIRE INSULATION TO BE USED WITH THIS CONNECTOR ASSEMBLY IS .072 [1.83] DIAMETER.
- FOR CONTACT CRIMPING INSTRUCTION SHEET REFER TO AMP IS 408-7516. FOR CONTACT INSTALLATION AND REMOVAL INSTRUCTION SHEET REFER TO AMP IS 408-7508.
- PART NUMBER FOR ORDERING.
- DIMENSIONS AND TOLERANCES PER ANSI Y14.5M-1982.
- THIS DRAWING SHALL BE INTERPRETED IN ACCORDANCE WITH APPLICABLE STANDARDS LISTED IN MIL-STD-100.

| | | | | | | | | | | | | | | | | | |
|--------------------------------|----------------------------------|------------------------------------|------------------------------------|----------------------------------|----------------------------------|----------------------------------|----------------------------------|-----------------|-----------------|--------------------|-----------|------------|----------------------|---------------------------|----------------------|-------------|----------|
| .049 [1.24] .029 [0.74] | .544 [13.82] .524 [13.31] | 2.188 [55.58] 2.168 [55.07] | 2.282 [57.96] 2.262 [57.45] | .248 [6.30] .238 [6.05] | .439 [11.15] .419 [10.64] | .620 [15.75] .590 [14.99] | .428 [10.87] .418 [10.62] | 2.411 [61.24] | 2.069 [52.55] | 2.650 [67.31] | MS18277-1 | 50 | 5 | M24308/6-5F | M24308/6-5F | 593039-5 | 593039-5 |
| | | | | | | | | 2.401 [60.99] | 2.059 [52.30] | 2.620 [66.55] | | | | | | | |
| .040 [1.02] .020 [0.51] | .432 [10.97] .412 [10.46] | 1.635 [41.53] 1.615 [41.02] | 1.093 [27.76] 1.073 [27.25] | .769 [19.53] .749 [19.02] | .509 [12.93] .479 [12.17] | .316 [8.03] .306 [7.77] | 2.505 [63.63] | 2.164 [54.97] | 2.744 [69.70] | MS18276-1 | 37 | 4 | M24308/6-4F | M24308/6-4F | 593039-4 | 593039-4 | |
| | | | | | | | 2.495 [63.37] | 2.154 [54.71] | 2.714 [68.94] | | | | | | | | |
| | | | | | | | 1.857 [47.17] | 1.516 [38.51] | 2.103 [53.42] | MS18275-1 | 25 | 3 | M24308/6-3F | M24308/6-3F | 593039-3 | 593039-3 | |
| | | | | | | | 1.847 [46.91] | 1.506 [38.25] | 2.073 [52.65] | | | | | | | | |
| | | | | | | | 1.317 [33.45] | .976 [24.79] | 1.556 [39.52] | MS18274-1 | 15 | 2 | M24308/6-2F | M24308/6-2F | 593039-2 | 593039-2 | |
| | | | | | | | 1.307 [33.20] | .966 [24.54] | 1.526 [38.76] | | | | | | | | |
| | | | | | | | .989 [25.12] | .648 [16.46] | 1.228 [31.19] | MS18273-1 | 9 | 1 | M24308/6-1F | M24308/6-1F | 593039-1 | 593039-1 | |
| | | | | | | | .979 [24.87] | .638 [16.21] | 1.198 [30.43] | | | | | | | | |
| L | J | H | G | F | E | D | C | B | A | INSERT ARRANGEMENT | NO OF POS | SHELL SIZE | PACKAGE MILITARY P/N | MILITARY P/N ON CONNECTOR | AMP P/N ON CONNECTOR | PART NUMBER | |

THIS DRAWING IS A CONTROLLED DOCUMENT.

| | | | | | | | |
|--------------------|--|--------------|--------------|--------------|--------------|--------------|---------------|
| DIMENSIONS: INCHES | TOLERANCES UNLESS OTHERWISE SPECIFIED: | 0 PLC ± .005 | 1 PLC ± .005 | 2 PLC ± .005 | 3 PLC ± .005 | 4 PLC ± .005 | ANGLES ± .005 |
|--------------------|--|--------------|--------------|--------------|--------------|--------------|---------------|

MATERIAL: SEE CALLOUTS
FINISH: SEE CALLOUTS

APPROVALS:
 DMN: AJ GRAFF 11-17-92
 CDR: B GILLMAN 11-18-92
 APVD: F KINSEY 18NOV92
 NAME: F KINSEY
 PRODUCT SPEC: MIL-C-24308
 APPLICATION SPEC: -

WEIGHT: -
 SIZE: A1
 CASE CODE: 00779
 DRAWING NO: 593039
 RESTRICTED TO: -

CUSTOMER DRAWING
 SCALE: 4:1
 SHEET: 1 of 1
 REV: C

STE TE Connectivity
 AMPLIMITE NONMAGNETIC RECEPTACLE ASSY WITH SIZE 20 CRIMP TYPE SOCKET CONTACTS, SERIES 109.