

LOC	DIST	REVISIONS			
AA	22	REV	DATE	BY	APPV
C4	ECR-12-003298	13FEB2012	JJ	AC	
D	REV PER ECR-13-009307	8JUN2013	D.Z	S.H	
E	ECO-15-006810	29DEC2015	LL	SH	
E1	REVISED PER ECO-21-000623	28JUL2020	IT	SH	

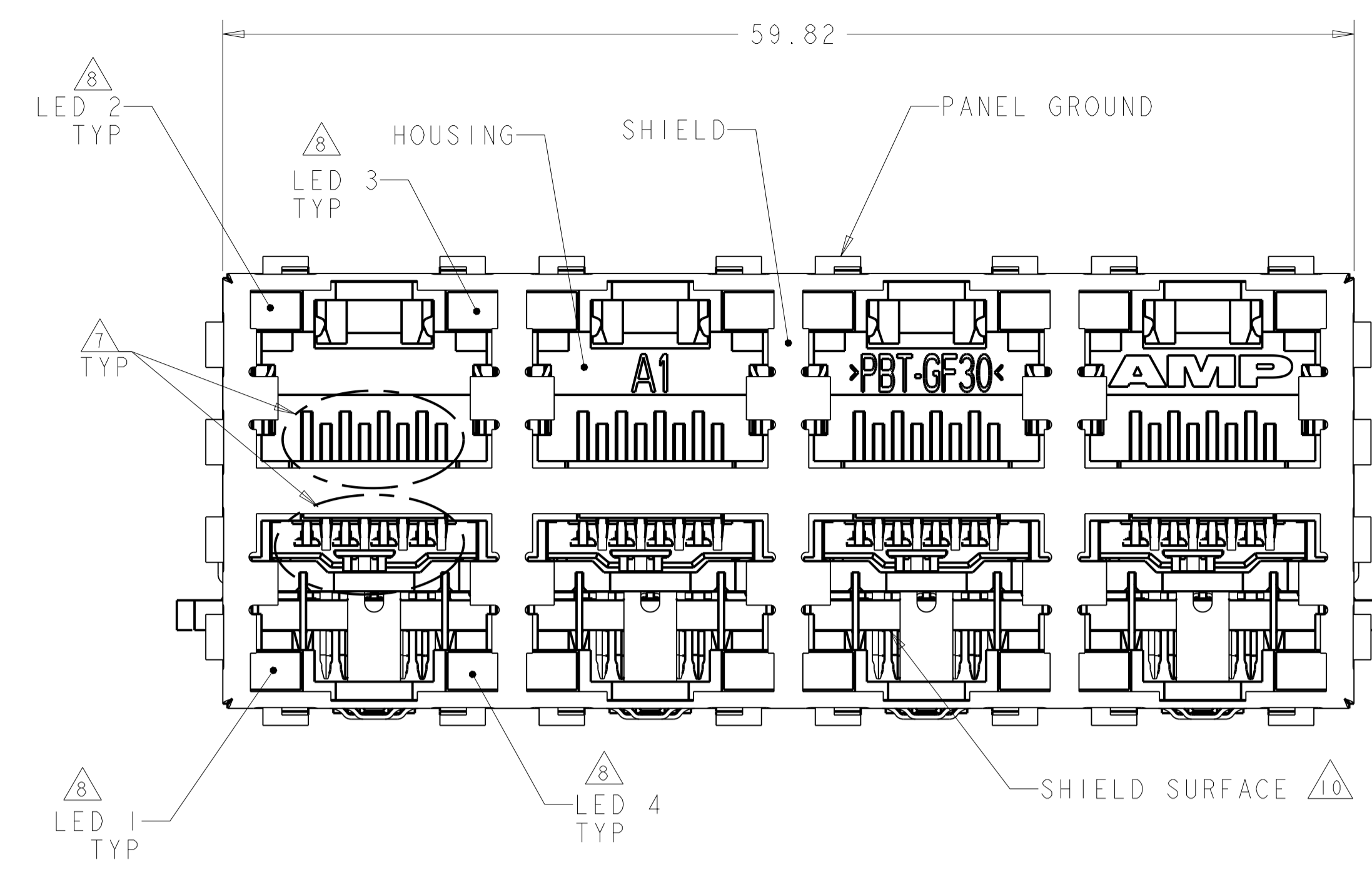

P/N 6368062-2 SHOWN

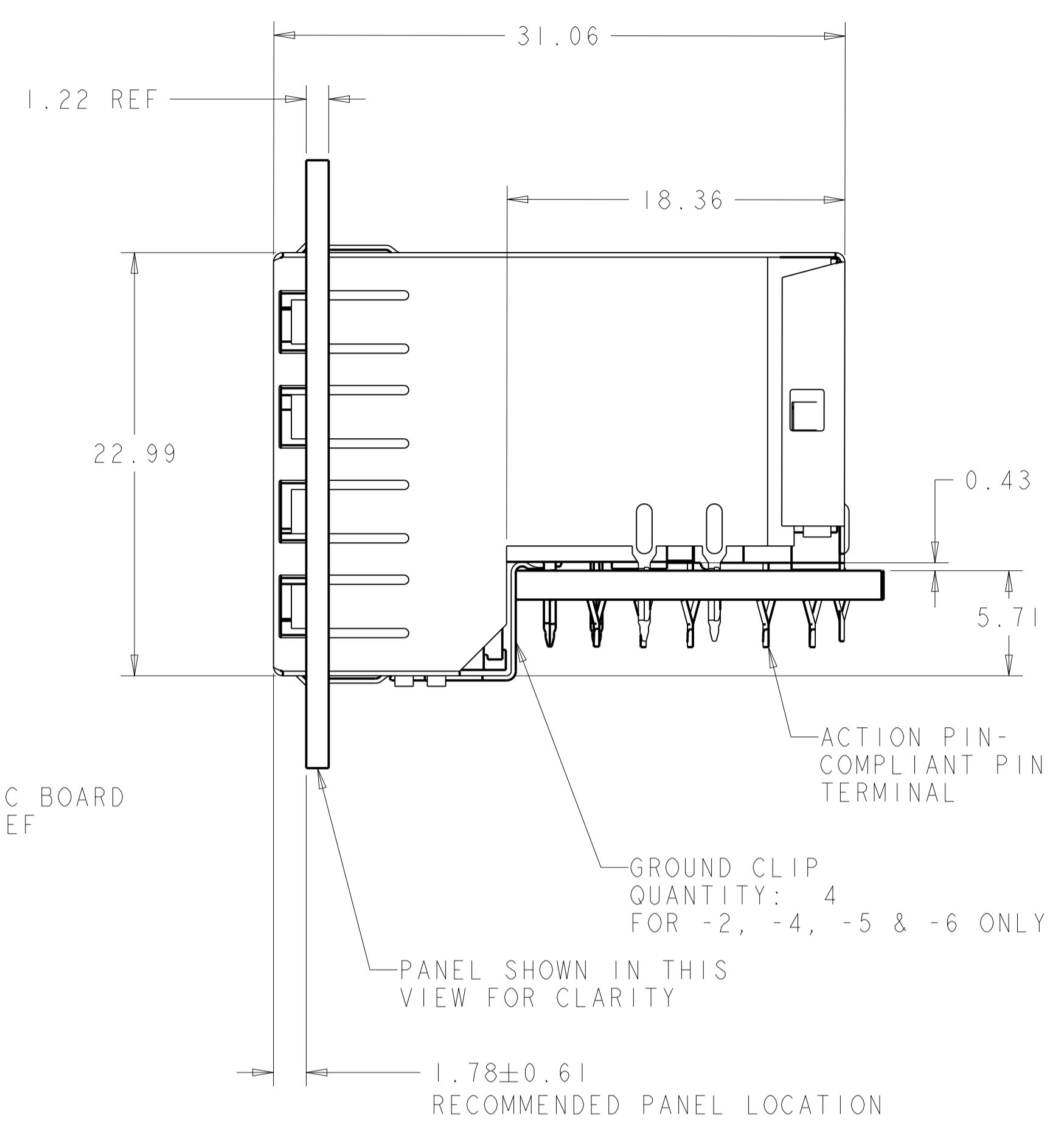

- MATERIAL:  
HOUSING: PBT POLYESTER, BLACK, UL 94V-0.  
TERMINALS: 0.33 THICK PHOSPHOR BRONZE PLATED WITH 1.27µm MINIMUM THICK HARD GOLD IN LOCALIZED AREA AND 3.81µm MINIMUM THICK MATTE TIN IN ACTION PIN COMPLIANT PIN TERMINAL AREA OVER 1.27µm MINIMUM THICK NICKEL UNDERPLATE.  
SHIELD: 0.25 THICK COPPER ALLOY PLATED WITH 1.27 µm MINIMUM NICKEL  
LIGHT EMITTING DIODE (LED): DIFFUSED EPOXY LENS, 12.95 CARBON STEEL WIREFRAME LEADS PREPLATED WITH 8.89 µm THICK Sn/Cu OVER 2.03 µm THICK Ag OVER 1.02 µm THICK Cu OVER 3.56 µm THICK Ni OVER 1.02 µm THICK Cu UNDERPLATE  
LED ACTION PIN - COMPLIANT PIN CONTACTS: 0.3 THICK BRASS PLATED WITH 2µm MINIMUM MATTE TIN OVER 1.27µm MINIMUM NICKEL UNDERPLATE.
- JACK CAVITY CONFORMS TO FCC RULES AND REGULATIONS, PART 68 SUBPART F.
- ALL DIMENSIONS ARE NOMINAL UNLESS OTHERWISE SPECIFIED.
- DRILLED HOLE DIA = 1.02±.025.  
COPPER THICKNESS = 0.025-0.075.  
TIN LEAD THICKNESS = 0.008 MIN.
- DATUMS AND BASIC DIMENSIONS ESTABLISHED BY CUSTOMER.
- DATE CODE LOCATED ON REAR OF PART APPROXIMATELY AS SHOWN.
- CONTACTS ARE NOT INTENDED TO BE ALIGNED WITH EACH OTHER.
- SUGGESTED OPERATING CURRENT FOR LEDS IS 20 mA.
- TWO LEDS PER PORT, SIZE .079 X .118, SEE TABLE FOR COLOR
- CLEAR 0.038 MIN THICK SURFACE PROTECTION TAPE APPLIED TO SHIELD SURFACE. FILM DOES NOT HAVE CUTOUTS IN EACH PORT. REMOVE TAPE PRIOR TO MATING A MODULAR PLUG TO THE JACK
- MATERIAL:  
SHIELD: 0.25 THICK COPPER ALLOY PLATED WITH 1.27 µm MINIMUM SATIN NICKEL.
- THE PART NUMBER 6368062-7 IS PRELIMINARY.
- ONLY FOR 6368062-8  
CONTACT AREA LUBRICATED WITH BELLCORE APPROVED LUBRICANT TECHNICAL REFERENCE GR-1217-CORE ISSUE 1, NOVEMBER 1995.
- THE PART 6368062-9 IS ONLY FOR CUSTOMER ZYNX SPECIAL LED LUMINOUS INTENSITY REQUEST. ( GREEN:13-20 mcd. YELLOW:6-9 mcd.)

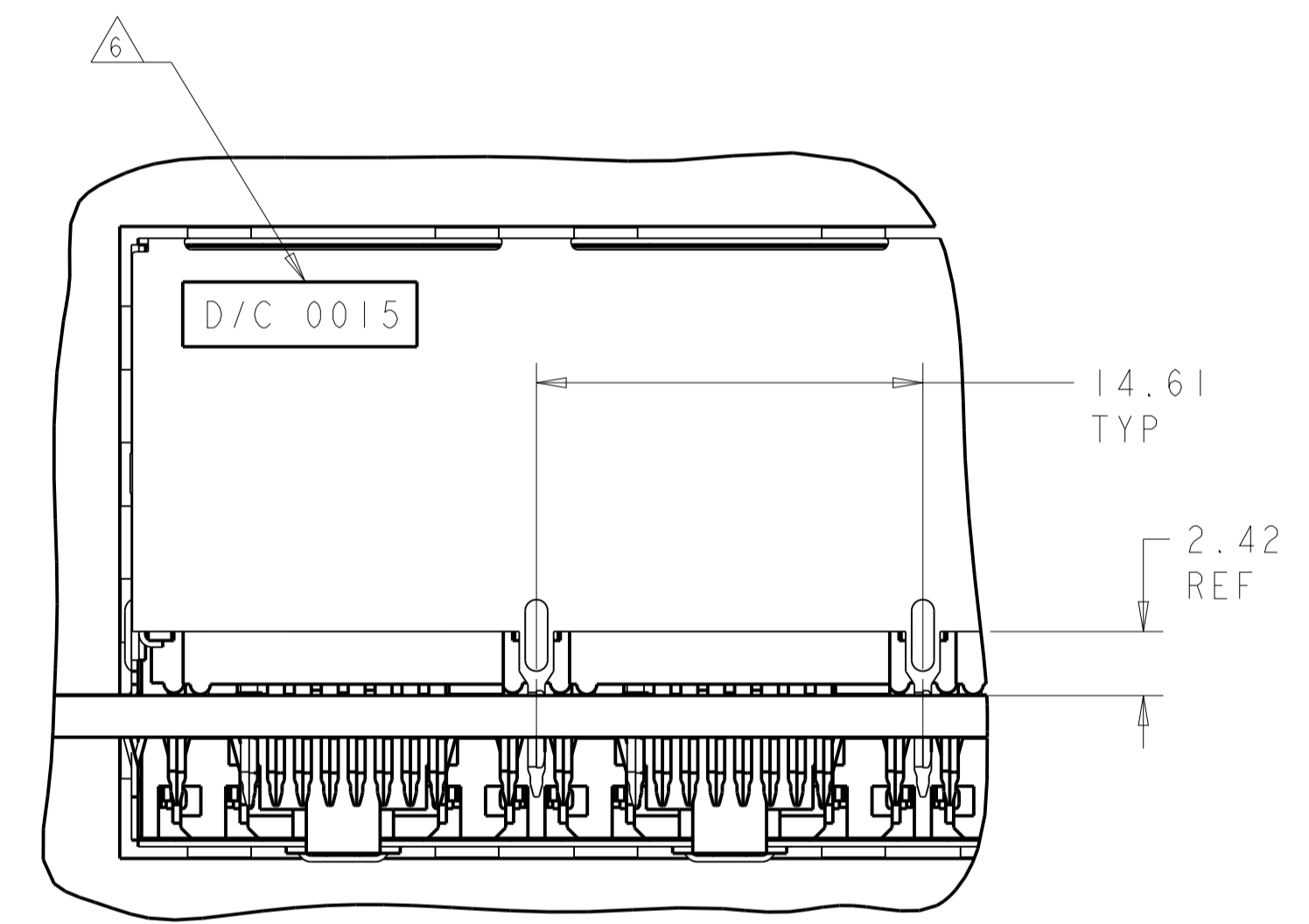

PARTIAL BACK VIEW

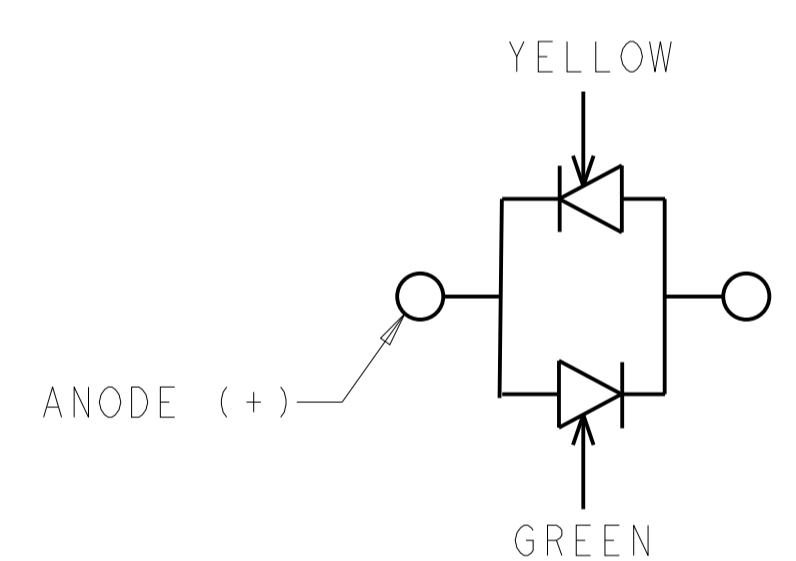

LED CURRENT DIAGRAM 6368062-4, -7

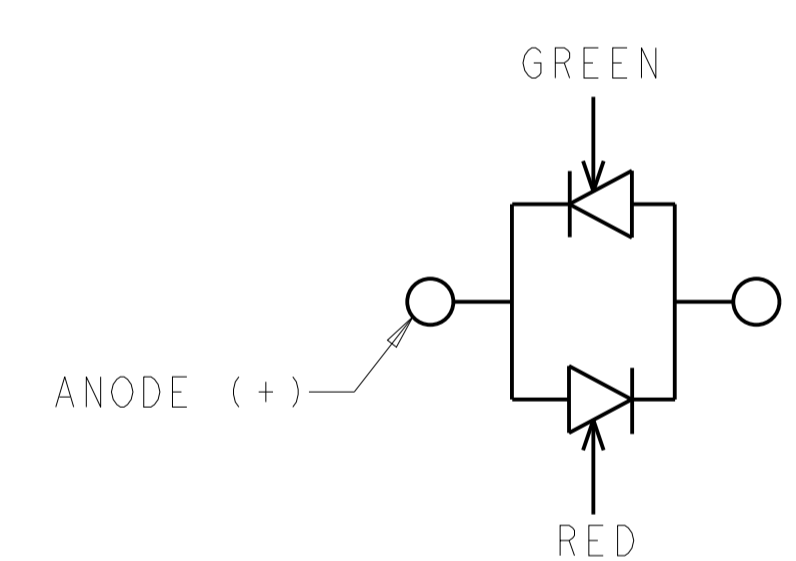

LED CIRCUIT DIAGRAM 6368062-6

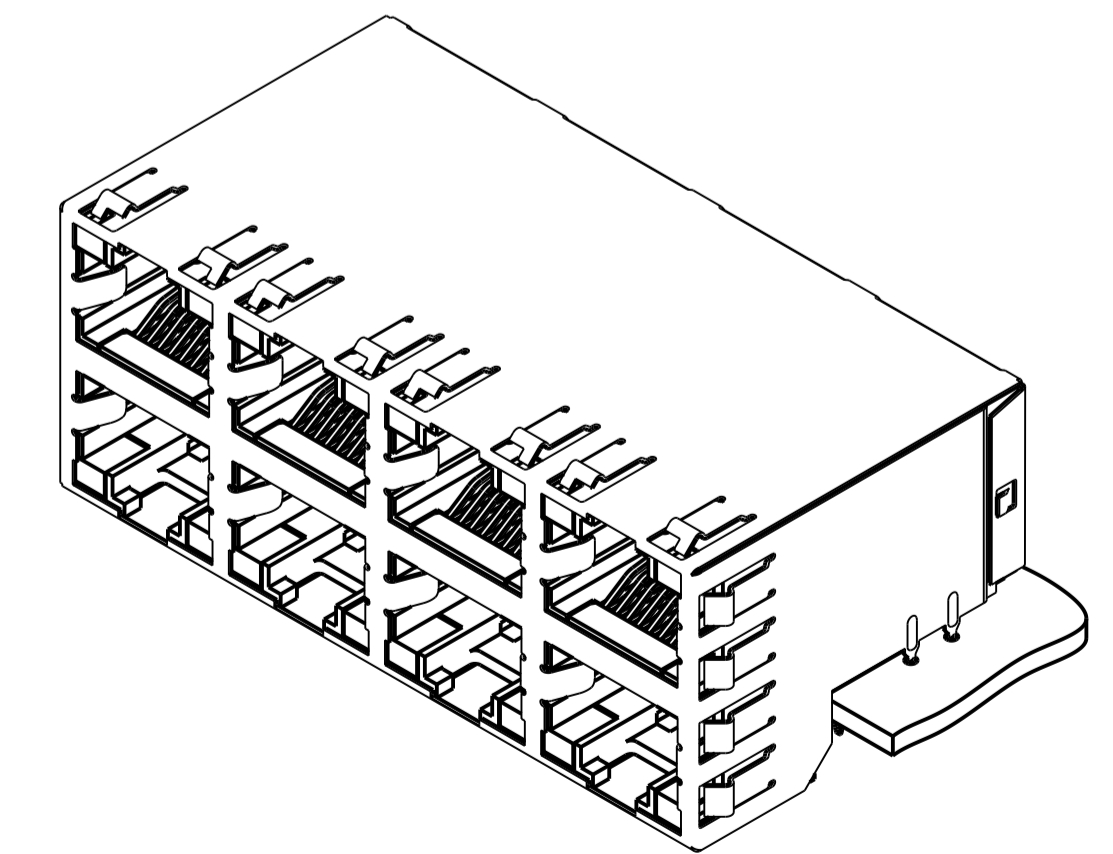

PN 6368062-1, -2, -3, -4, -5, -6, -8 AND 1-6368062-6 SCALE 2:1

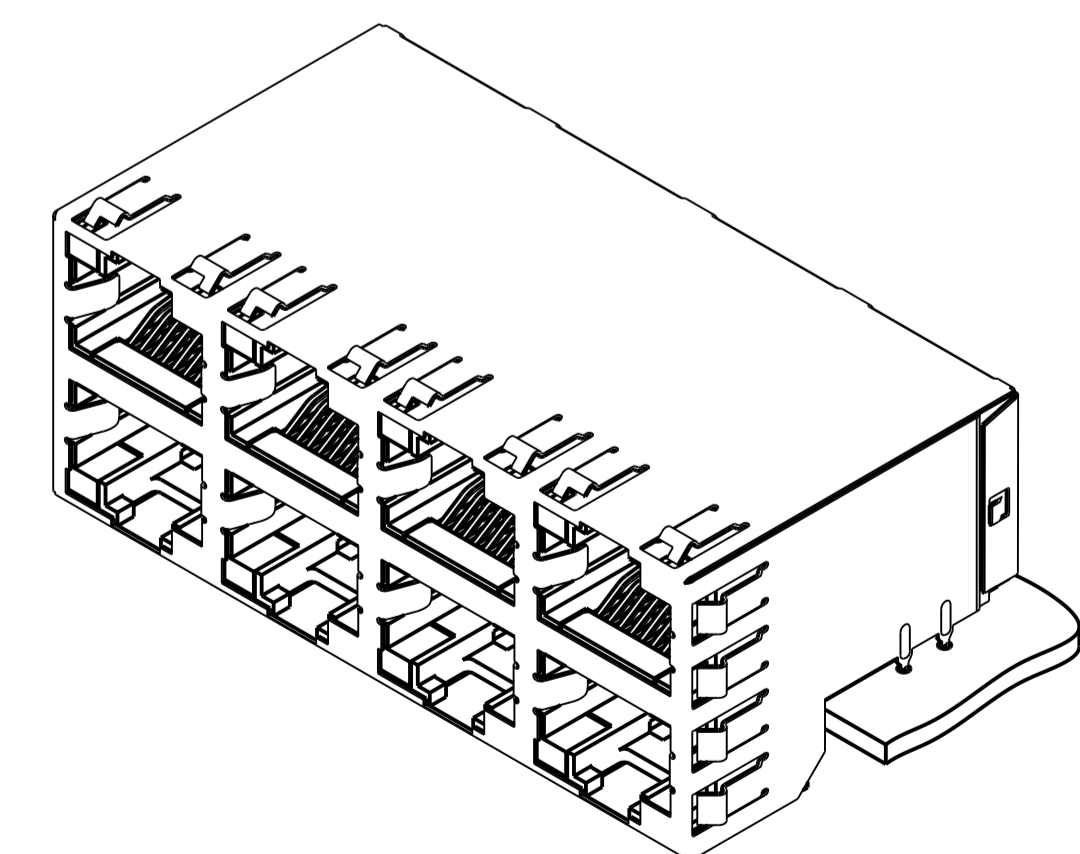

PN 6368062-7 SCALE 2:1

REMARKS	LED #4 (LOWER-RIGHT)	LED #3 (UPPER-RIGHT)	LED #2 (UPPER-LEFT)	LED #1 (LOWER-LEFT)	DESCRIPTION	PART NUMBER
	YELLOW	YELLOW	GREEN	GREEN	WITHOUT GROUND CLIP	1-6368062-6
	YELLOW	YELLOW	GREEN	GREEN	WITHOUT GROUND CLIP	6368062-9
	GREEN	GREEN	GREEN	GREEN	WITHOUT GROUND CLIP	6368062-8
	N/A	N/A	GREEN/YELLOW	GREEN/YELLOW	WITHOUT GROUND CLIP	6368062-7
	RED/GREEN	RED/GREEN	RED/GREEN	RED/GREEN	WITH GROUND CLIP	6368062-6
	GREEN	GREEN	GREEN	GREEN	WITH GROUND CLIP	6368062-5
	GREEN/YELLOW	GREEN/YELLOW	GREEN/YELLOW	GREEN/YELLOW	WITH GROUND CLIP	6368062-4
	YELLOW	YELLOW	GREEN	GREEN	WITHOUT GROUND CLIP	6368062-3
	GREEN	GREEN	GREEN	GREEN	WITH GROUND CLIP	6368062-2
	GREEN	GREEN	GREEN	GREEN	WITHOUT GROUND CLIP	6368062-1

THIS DRAWING IS A CONTROLLED DOCUMENT.

OWN: L.A.MAYER 15APR2005  
CHK: J.WESTMAN 15APR2005  
APPV: S.FELICKINGER 15APR2005

TE Connectivity

NAME: STACKED MODULAR JACK ASSEMBLY, 2x4 OFFSET, WITH LEDS, 8 POSN, RJ45 SHIELDED, PANEL GROUNDS, CAT 5

PRODUCT SPEC: 108-1854  
APPLICATION SPEC: 114-2160  
SIZE: 100779  
WEIGHT: -  
Customer Drawing

SCALE: 4:1 SHEET 1 OF 2 REV E1

LOC	DIST	REV	DATE	BY	APPV
AA	22				

REVISIONS					
REV	DATE	BY	APPV	DESCRIPTION	DATE
-	-	-	-	SEE SHEET 1	-

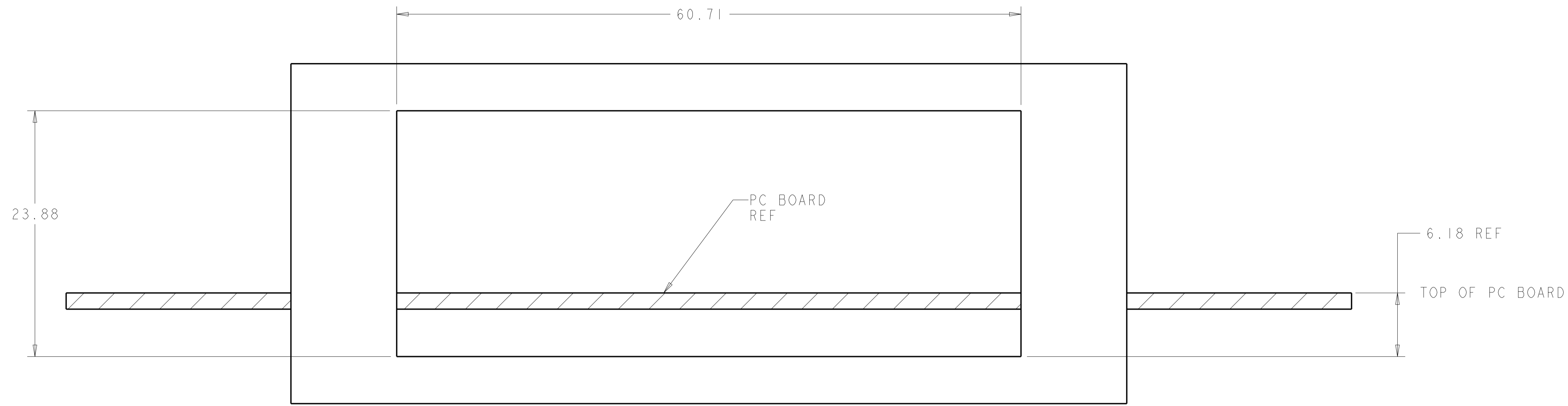

RECOMMENDED PANEL CUT-OUT

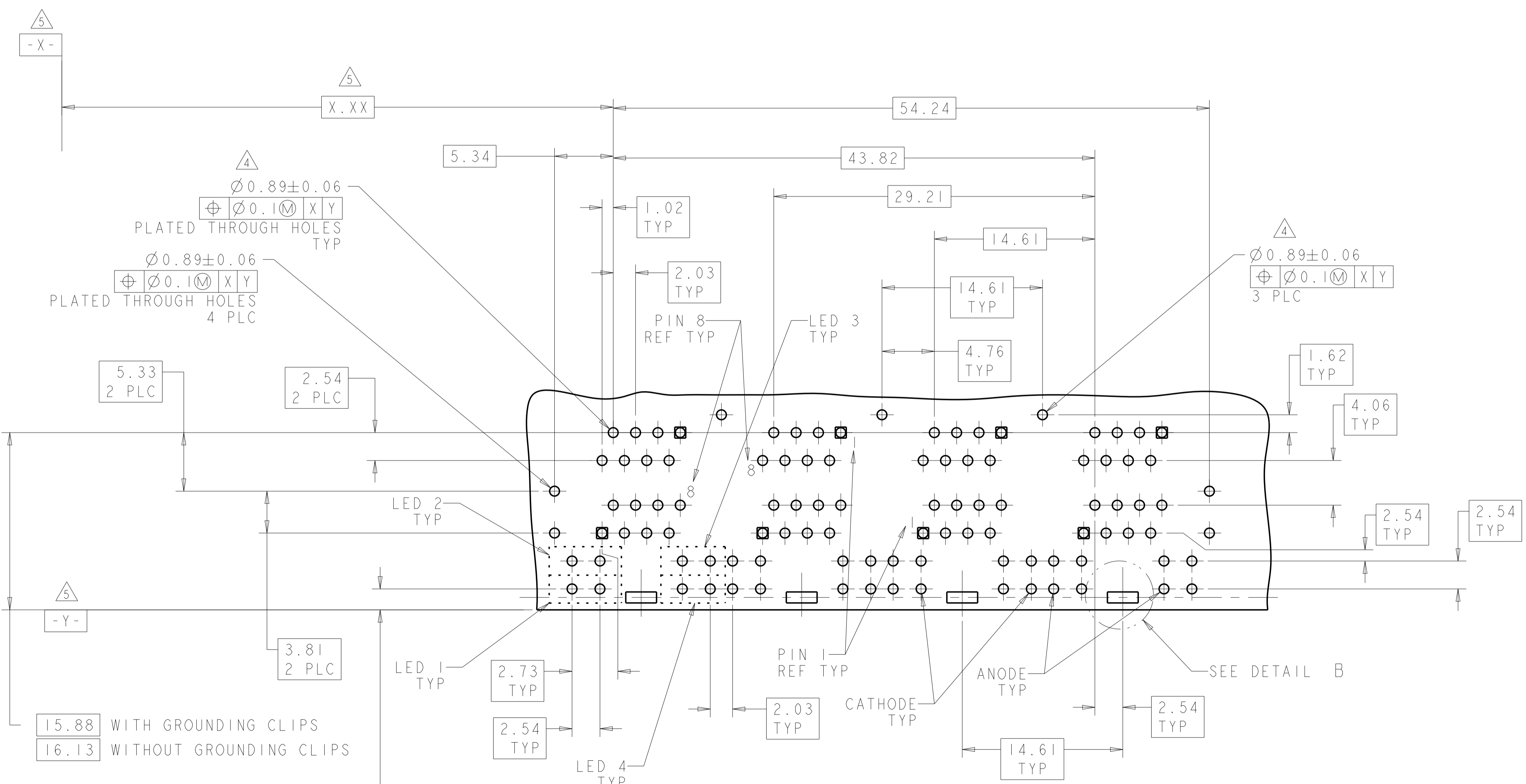

PC BOARD LAYOUT  
(COMPONENT SIDE)  
LED #3, #4 NOT REQUIRED FOR 6368062-7

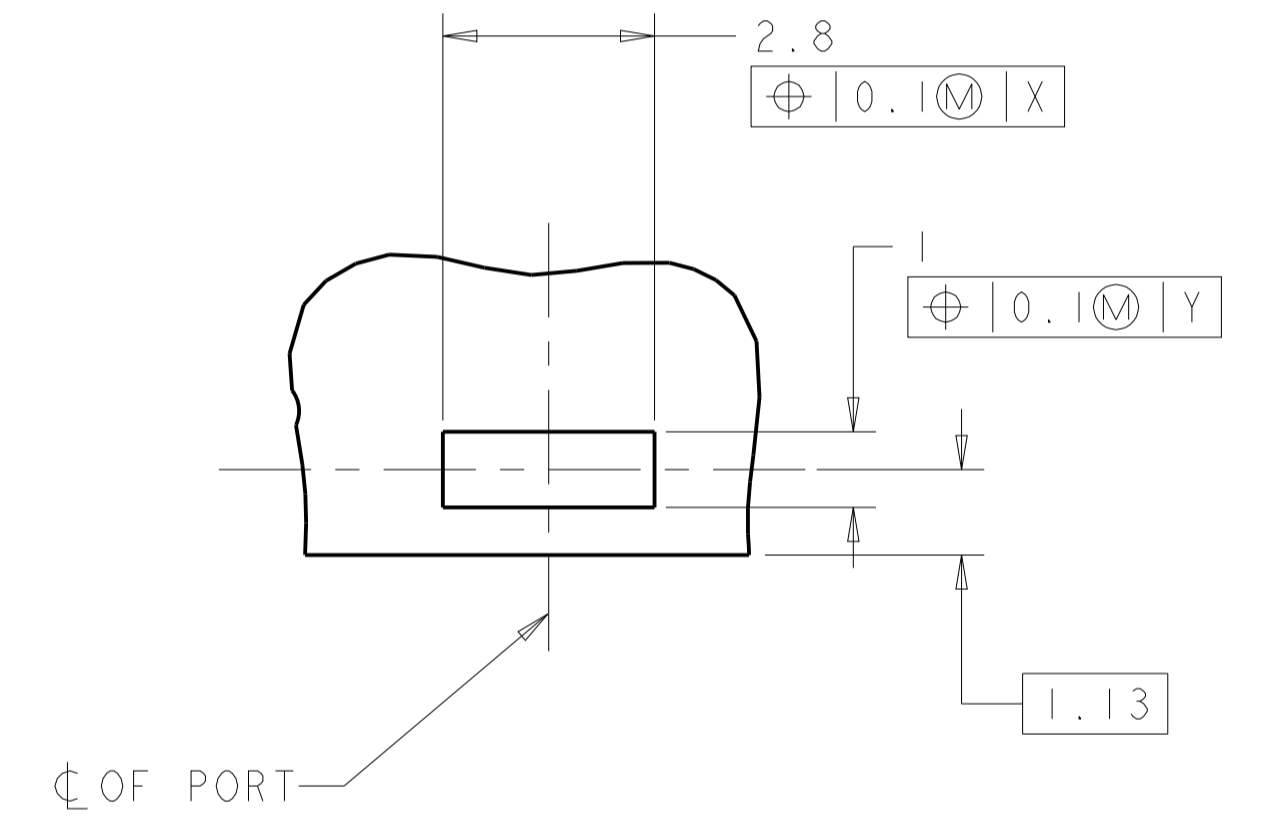

DETAIL B  
PLATED PADS REQUIRED FOR 6368062-2, -4, -5 & -6  
(PRODUCT WITH GROUNDING CLIPS)  
SCALE 10:1  
4 PLACES

PARTS WITH GROUNDING CLIPS = 1.65  
PARTS WITHOUT GROUNDING CLIPS = 1.91

THIS DRAWING IS A CONTROLLED DOCUMENT.		OWN L.A. MAYER 15APR2005	TE Connectivity
DIMENSIONS:		CHK J. WESTMAN 15APR2005	
mm	TOLERANCES UNLESS OTHERWISE SPECIFIED:	APPV S. FLICKINGER 15APR2005	NAME STACKED MODULAR JACK ASSEMBLY, 2x4 OFFSET, WITH LEDS, 8 POSN, RJ45 SHIELDED, PANEL GROUNDS, CAT 5
Ø	0 PLC ±	PRODUCT SPEC	SIZE A100779
	1 PLC ±0.13	APPLICATION SPEC	SCALE 4:1
	2 PLC ±	108-1854	SHEET 2 OF 2
	3 PLC ±	114-2160	REV E1
	4 PLC ±	WEIGHT	
	ANGLES ±	Customer Drawing	