

REV	ECO	DATE
A	UPDATED	6/15/1993
B	13716	6/22/1994
M	58304	6/23/2022

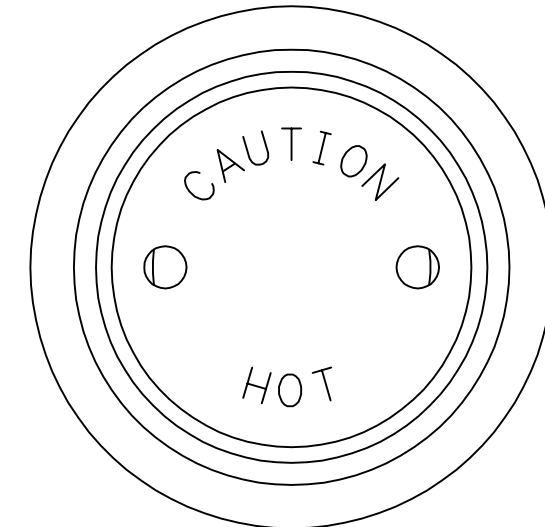
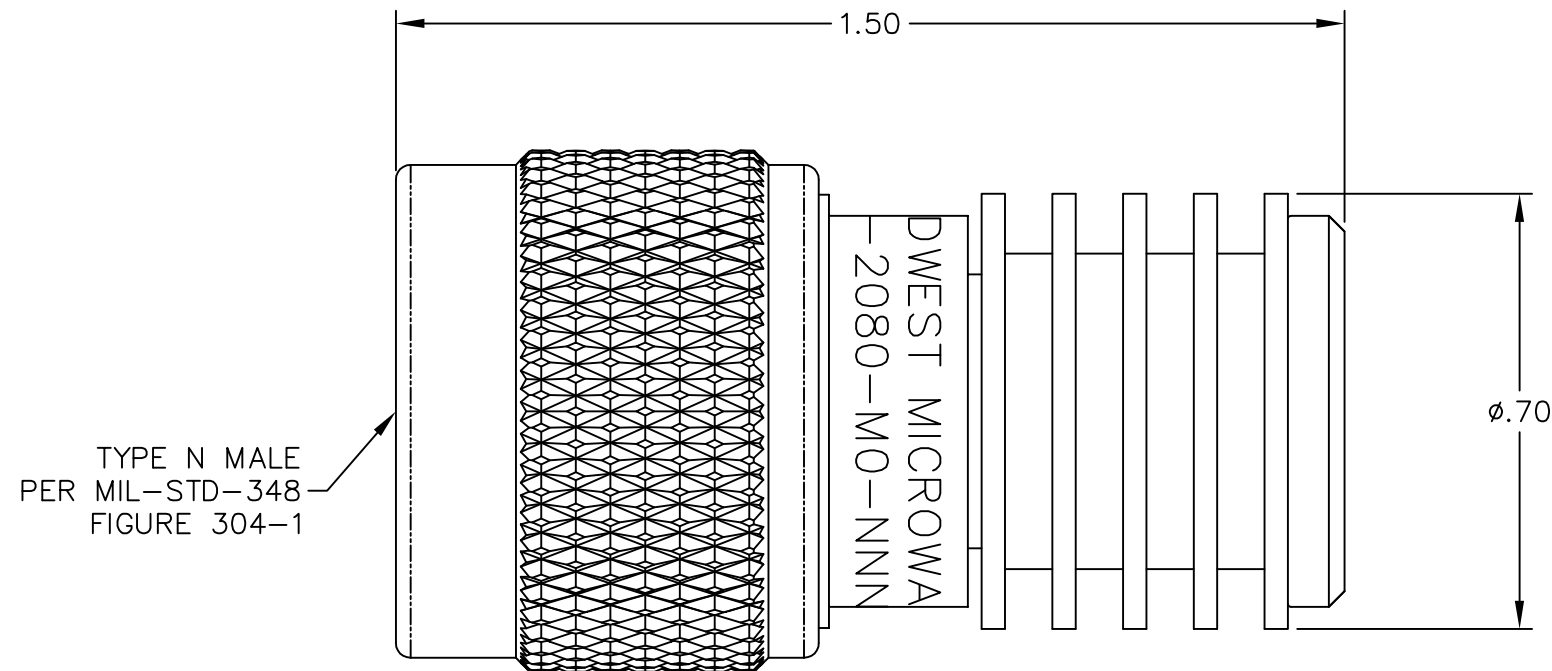

NOTES:

1. MATERIAL & FINISH:

- 1.1. BODY & COUPLING NUT: PASSIVATED STAINLESS STEEL
- 1.2. HEAT SINK: BLACK ANODIZED ALUMINUM
- 1.3. END PLUG: GOLD PLATED BRASS
- 1.4. DIELECTRIC: PTFE (TEFLON)
- 1.5. CENTER CONTACT: GOLD PLATED BERYLLIUM COPPER
- 1.6. GASKET: SILICONE RUBBER

2. SPECIFICATIONS:

- 2.1. FREQUENCY RANGE: DC TO 12.4 GHz
- 2.2. VSWR (MAX): 1.05+0.01f (GHz)
- 2.3. INPUT POWER:
 - 2.3.1. AVERAGE: 10 WATTS AT +25°C, DERATED LINEARLY TO 1 WATT AT +125°C
 - 2.3.2. PEAK: 250 WATTS
- 2.4. IMPEDANCE: 50 OHMS NOMINAL
- 2.5. OPERATING TEMPERATURE RANGE: -54°C TO +125°C

<p>NOTICE: The information in this drawing is PROPRIETARY and must not be used without the permission of Cinch Connectivity Solutions. It may contain data whose export is restricted. Verify status prior to exporting.</p> <p>INTERPRET DRAWING IN ACCORDANCE WITH ASME Y14.5-2018</p>	Model No. TRM-2080-M0-NNN-07	Title: MIDWEST MICROWAVE TERMINATION TYPE N MALE	
	RoHS2 <input checked="" type="checkbox"/> 2015/863/EU	Cage Code 34078	Rev. M
	UNLESS OTHERWISE SPECIFIED UNITS: INCH	3RD ANGLE PROJECTION 	Drawing No. TRM-2080-M0-NNN-07-01
	.XX ± .02 .XXX ± .005 ANGLES ± 2°	Engineer: J.KEREKES	Workmanship Std: SHEET 1 OF 1
	Date: 6/23/22	SIZE A	DO NOT SCALE DRAWING