

April 1995

50A, 400V - 600V Hyperfast Diodes

Features

- Hyperfast with Soft Recovery <45ns
- Operating Temperature +175°C
- Reverse Voltage Up To 600V
- Avalanche Energy Rated
- Planar Construction

Applications

- Switching Power Supplies
- Power Switching Circuits
- General Purpose

Description

RHRU5040, RHRU5050 and RHRU5060 (TA49065) are hyperfast diodes with soft recovery characteristics ($t_{RR} < 45ns$). They have half the recovery time of ultrafast diodes and are silicon nitride passivated ion-implanted epitaxial planar construction.

These devices are intended for use as freewheeling/clamping diodes and rectifiers in a variety of switching power supplies and other power switching applications. Their low stored charge and hyperfast soft recovery minimize ringing and electrical noise in many power switching circuits reducing power loss in the switching transistors.

PACKAGING AVAILABILITY

PART NUMBER	PACKAGE	BRAND
RHRU5040	TO-218	RHRU5040
RHRU5050	TO-218	RHRU5050
RHRU5060	TO-218	RHRU5060

NOTE: When ordering, use the entire part number.

Package

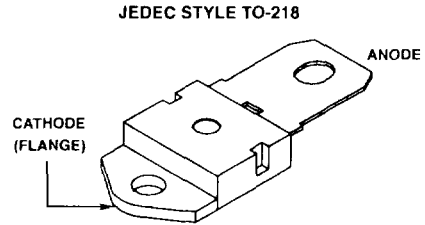

Symbol



Absolute Maximum Ratings $T_C = +25^\circ C$, Unless Otherwise Specified

	RHRU5040	RHRU5050	RHRU5060	UNITS
Peak Repetitive Reverse Voltage V_{RRM}	400	500	600	V
Working Peak Reverse Voltage V_{RWM}	400	500	600	V
DC Blocking Voltage V_R	400	500	600	V
Average Rectified Forward Current $I_{F(AV)}$ ($T_C = +93^\circ C$)	50	50	50	A
Repetitive Peak Surge Current I_{FSM} (Square Wave, 20kHz)	100	100	100	A
Nonrepetitive Peak Surge Current I_{FSM} (Halfwave, 1 Phase, 60Hz)	500	500	500	A
Maximum Power Dissipation P_D	150	150	150	W
Avalanche Energy ($L = 40mH$) E_{AVL}	40	40	40	mJ
Operating and Storage Temperature T_{STG}, T_J	-65 to +175	-65 to +175	-65 to +175	$^\circ C$

7
HYPERFAST
SINGLE DIODES

Specifications RHRU5040, RHRU5050, RHRU5060

Electrical Specifications $T_C = +25^\circ\text{C}$, Unless Otherwise Specified

SYMBOL	TEST CONDITION	RHRU5040			RHRU5050			RHRU5060			UNITS
		MIN	TYP	MAX	MIN	TYP	MAX	MIN	TYP	MAX	
V_F	$I_F = 50\text{A}, T_C = +25^\circ\text{C}$	-	-	2.1	-	-	2.1	-	-	2.1	V
	$I_F = 50\text{A}, T_C = +150^\circ\text{C}$	-	-	1.7	-	-	1.7	-	-	1.7	V
I_R	$V_R = 400\text{V}, T_C = +25^\circ\text{C}$	-	-	500	-	-	-	-	-	-	μA
	$V_R = 500\text{V}, T_C = +25^\circ\text{C}$	-	-	-	-	-	500	-	-	-	μA
	$V_R = 600\text{V}, T_C = +25^\circ\text{C}$	-	-	-	-	-	-	-	-	500	μA
I_R	$V_R = 400\text{V}, T_C = +150^\circ\text{C}$	-	-	1.5	-	-	-	-	-	-	mA
	$V_R = 500\text{V}, T_C = +150^\circ\text{C}$	-	-	-	-	-	1.5	-	-	-	mA
	$V_R = 600\text{V}, T_C = +150^\circ\text{C}$	-	-	-	-	-	-	-	-	1.5	mA
t_{RR}	$I_F = 1\text{A}, dI_F/dt = 100\text{A}/\mu\text{s}$	-	-	45	-	-	45	-	-	45	ns
	$I_F = 50\text{A}, dI_F/dt = 100\text{A}/\mu\text{s}$	-	-	50	-	-	50	-	-	50	ns
t_A	$I_F = 50\text{A}, dI_F/dt = 100\text{A}/\mu\text{s}$	-	25	-	-	25	-	-	25	-	ns
t_B	$I_F = 50\text{A}, dI_F/dt = 100\text{A}/\mu\text{s}$	-	20	-	-	20	-	-	20	-	ns
Q_{RR}	$I_F = 50\text{A}, dI_F/dt = 100\text{A}/\mu\text{s}$	-	65	-	-	65	-	-	65	-	nC
C_J	$V_R = 10\text{V}, I_F = 0\text{A}$	-	140	-	-	140	-	-	140	-	pF
$R_{\theta JC}$		-	-	1.0	-	-	1.0	-	-	1.0	$^\circ\text{C}/\text{W}$

DEFINITIONS

V_F = Instantaneous forward voltage ($p_w = 300\mu\text{s}$, $D = 2\%$).

I_R = Instantaneous reverse current.

t_{RR} = Reverse recovery time (See Figure 2), summation of $t_A + t_B$.

t_A = Time to reach peak reverse current (See Figure 2).

t_B = Time from peak I_{RM} to projected zero crossing of I_{RM} based on a straight line from peak I_{RM} through 25% of I_{RM} (See Figure 2).

$R_{\theta JC}$ = Thermal resistance junction to case.

E_{AVL} = Controlled avalanche energy (See Figures 10 and 11).

p_w = pulse width.

D = duty cycle.

V_1 AMPLITUDE CONTROLS I_F
 V_2 AMPLITUDE CONTROLS dI_F/dt
 L_1 = SELF INDUCTANCE OF
 $R_4 + L_{\text{LOOP}}$

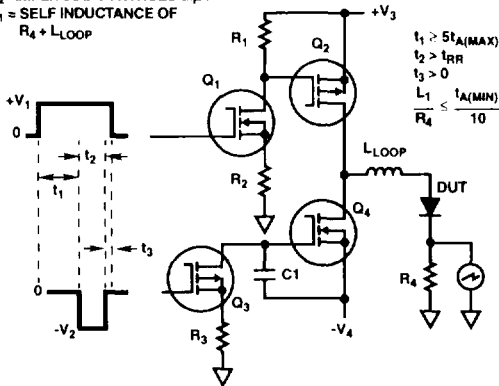

FIGURE 1. t_{RR} TEST CIRCUIT

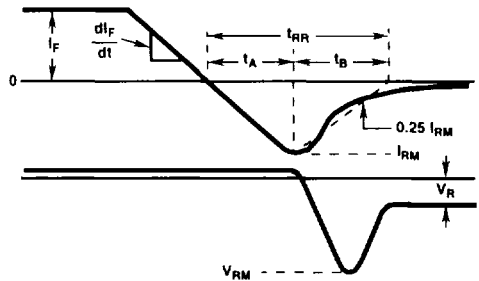

FIGURE 2. t_{RR} WAVEFORMS AND DEFINITIONS

Typical Performance Curves

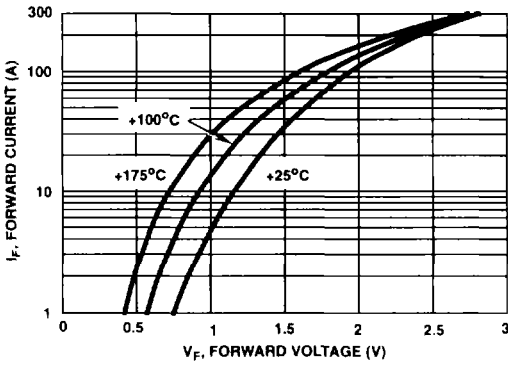

FIGURE 3. TYPICAL FORWARD CURRENT vs FORWARD VOLTAGE DROP

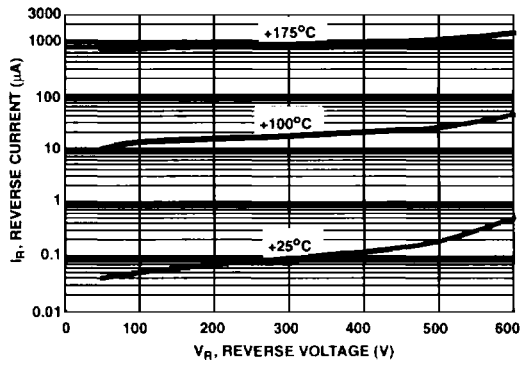

FIGURE 4. TYPICAL REVERSE CURRENT vs REVERSE VOLTAGE

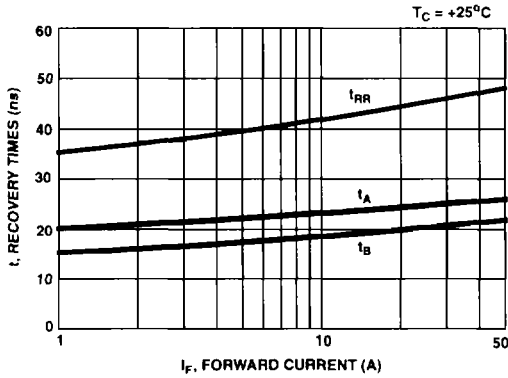

FIGURE 5. TYPICAL t_{RR} , t_A AND t_B CURVES vs FORWARD CURRENT AT +25°C

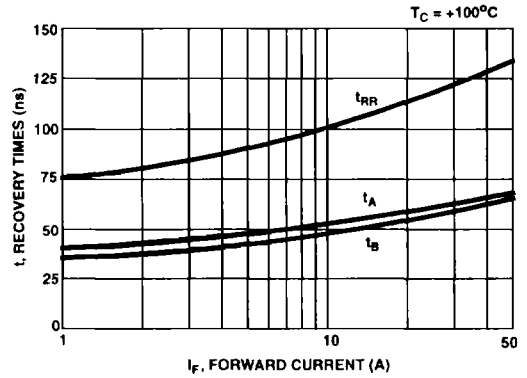

FIGURE 6. TYPICAL t_{RR} , t_A AND t_B CURVES vs FORWARD CURRENT AT +100°C

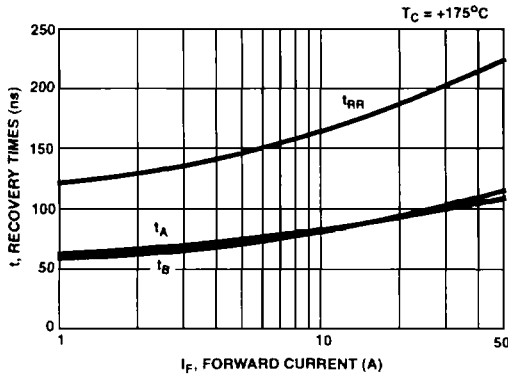

FIGURE 7. TYPICAL t_{RR} , t_A AND t_B CURVES vs FORWARD CURRENT AT +175°C

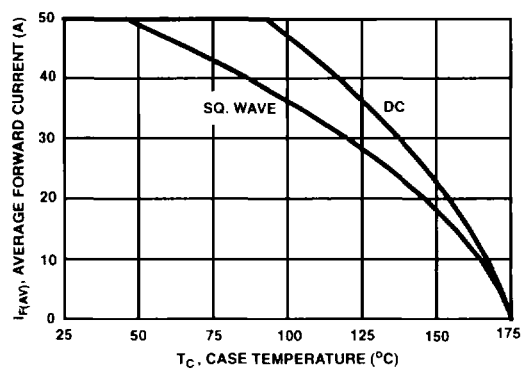

FIGURE 8. CURRENT DERATING CURVE FOR ALL TYPES

7
HYPERFAST
SINGLE DIODES

Typical Performance Curves (Continued)

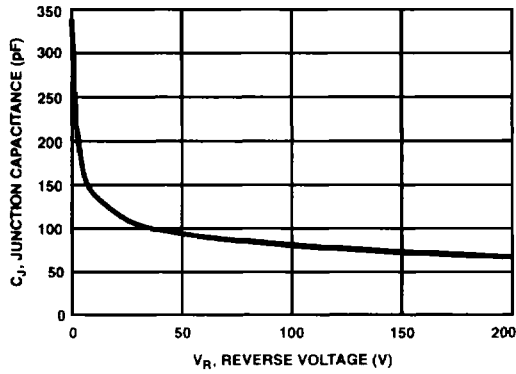

FIGURE 9. TYPICAL JUNCTION CAPACITANCE vs REVERSE VOLTAGE

Test Circuit and Waveforms

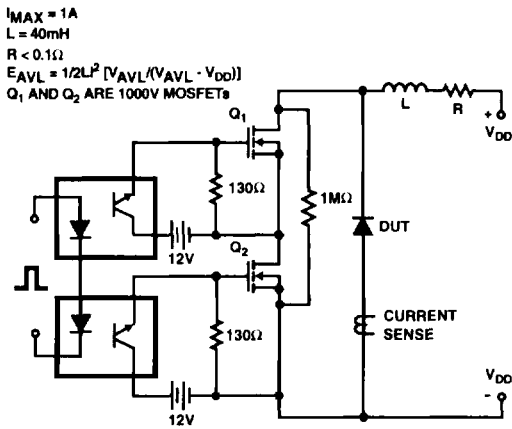

FIGURE 10. AVALANCHE ENERGY TEST CIRCUIT

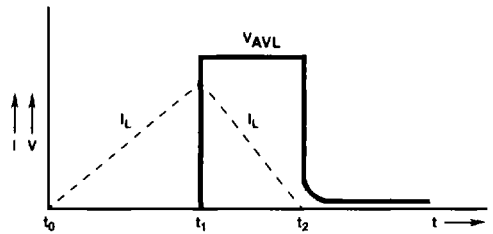

FIGURE 11. AVALANCHE CURRENT AND VOLTAGE WAVEFORMS