



# 74VHCT573A Octal D-Type Latch with 3-STATE Outputs

## Features

- High speed:  $t_{PD} = 7.7ns$  (Typ.) at  $T_A = 25^\circ C$
- High Noise Immunity:  $V_{IH} = 2.0V$ ,  $V_{IL} = 0.8V$
- Power Down Protection is provided on all inputs and outputs
- Low Noise:  $V_{OLP} = 1.6V$  (Max.)
- Low Power Dissipation:  $I_{CC} = 4\mu A$  (Max.) @  $T_A = 25^\circ C$
- Pin and function compatible with 74HCT573

## General Description

The VHCT573A is an advanced high speed CMOS octal latch with 3-STATE output fabricated with silicon gate CMOS technology. It achieves the high speed operation similar to equivalent Bipolar Schottky TTL while maintaining the CMOS low power dissipation. This 8-bit D-type latch is controlled by a Latch Enable input (LE) and an Output Enable input ( $\overline{OE}$ ). When the  $\overline{OE}$  input is HIGH, the eight outputs are in a high impedance state.

Protection circuits ensure that 0V to 7V can be applied to the input and output<sup>(1)</sup> pins without regard to the supply voltage. This device can be used to interface 3V to 5V systems and two supply systems such as battery back up. This circuit prevents device destruction due to mismatched supply and input voltages.

### Note:

1. Outputs in OFF-State

## Ordering Information

Order Number	Package Number	Package Description
74VHCT573AM	M20B	20-Lead Small Outline Integrated Circuit (SOIC), JEDEC MS-013, 0.300" Wide
74VHCT573ASJ	M20D	20-Lead Small Outline Package (SOP), EIAJ TYPE II, 5.3mm Wide
74VHCT573AMTC	MTC20	20-Lead Thin Shrink Small Outline Package (TSSOP), JEDEC MO-153, 4.4mm Wide

Surface mount packages are also available on Tape and Reel. Specify by appending the suffix letter "X" to the ordering number. Pb-Free package per JEDEC J-STD-020B.

## Connection Diagram

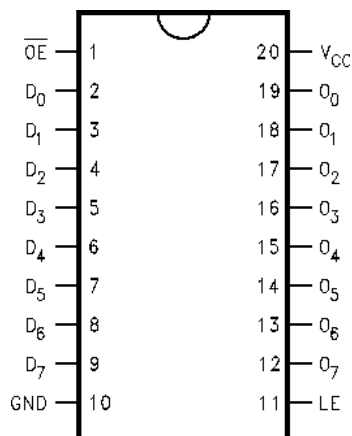

## Pin Description

Pin Names	Description
$D_0-D_7$	Data Inputs
LE	Latch Enable Input
$\overline{OE}$	3-STATE Output Enable Input
$O_0-O_7$	3-STATE Outputs

### Logic Symbol

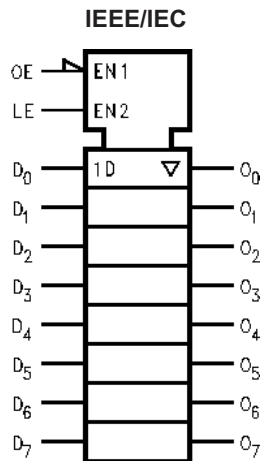

### Functional Description

The VHCT573A contains eight D-type latches with 3-STATE output buffers. When the Latch Enable (LE) input is HIGH, data on the  $D_n$  inputs enters the latches. In this condition the latches are transparent, i.e., a latch output will change state each time its D input changes. When LE is LOW the latches store the information that was present on the D inputs, a setup time preceding the HIGH-to-LOW transition of LE. The 3-STATE buffers are controlled by the Output Enable ( $\overline{OE}$ ) input. When  $\overline{OE}$  is LOW, the buffers are enabled. When  $\overline{OE}$  is HIGH the buffers are in the high impedance mode, but, this does not interfere with entering new data into the latches.

### Truth Table

Inputs			Outputs
$\overline{OE}$	LE	D	$O_n$
L	H	H	H
L	H	L	L
L	L	X	$O_0$
H	X	X	Z

H = HIGH Voltage Level

L = LOW Voltage Level

X = Immaterial

Z = High Impedance

### Logic Diagram

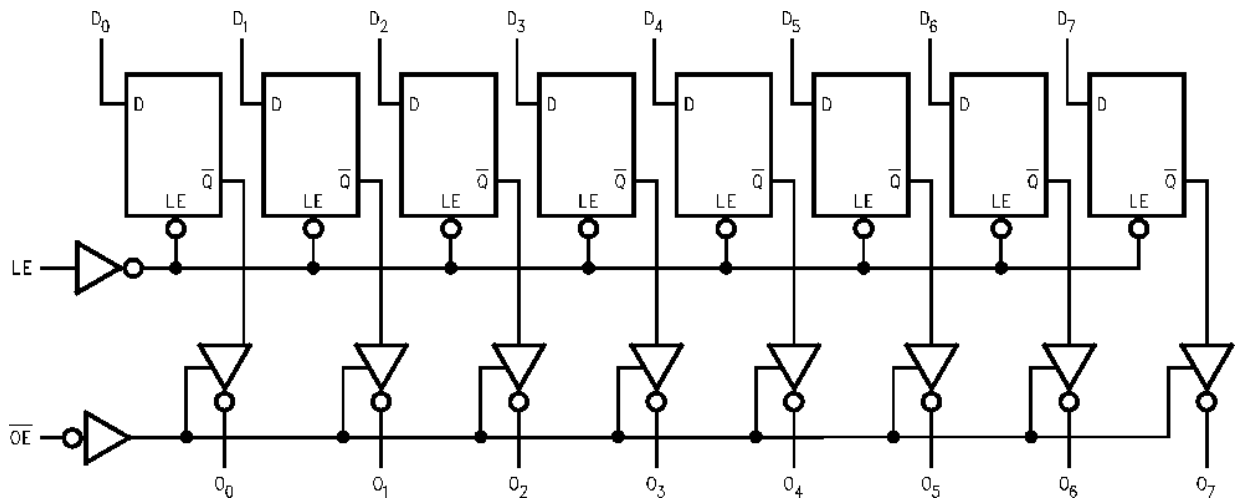

Please note that this diagram is provided only for the understanding of logic operations and should not be used to estimate propagation delays.

## Absolute Maximum Ratings

Stresses exceeding the absolute maximum ratings may damage the device. The device may not function or be operable above the recommended operating conditions and stressing the parts to these levels is not recommended. In addition, extended exposure to stresses above the recommended operating conditions may affect device reliability. The absolute maximum ratings are stress ratings only.

Symbol	Parameter	Rating
$V_{CC}$	Supply Voltage	-0.5V to +7.0V
$V_{IN}$	DC Input Voltage	-0.5V to +7.0V
$V_{OUT}$	DC Output Voltage Note 2 Note 3	-0.5V to $V_{CC} + 0.5V$ -0.5V to +7.0V
$I_{IK}$	Input Diode Current	-20mA
$I_{OK}$	Output Diode Current <sup>(4)</sup>	±20mA
$I_{OUT}$	DC Output Current	±25mA
$I_{CC}$	DC $V_{CC}/GND$ Current	±75mA
$T_{STG}$	Storage Temperature	-65°C to +150°C
$T_L$	Lead Temperature (Soldering, 10 seconds)	260°C

## Recommended Operating Conditions<sup>(5)</sup>

The Recommended Operating Conditions table defines the conditions for actual device operation. Recommended operating conditions are specified to ensure optimal performance to the datasheet specifications. Fairchild does not recommend exceeding them or designing to absolute maximum ratings.

Symbol	Parameter	Rating
$V_{CC}$	Supply Voltage	4.5V to +5.5V
$V_{IN}$	Input Voltage	0V to +5.5V
$V_{OUT}$	Output Voltage Note 2 Note 3	0V to $V_{CC}$ 0V to 5.5V
$T_{OPR}$	Operating Temperature	-40°C to +85°C
$t_r, t_f$	Input Rise and Fall Time, $V_{CC} = 5.0V \pm 0.5V$	0ns/V ~ 20ns/V

### Notes:

- HIGH or LOW state.  $I_{OUT}$  absolute maximum rating must be observed.
- When outputs are in OFF-State or when  $V_{CC} = 0V$ .
- $V_{OUT} < GND$ ,  $V_{OUT} > V_{CC}$  (Outputs Active).
- Unused inputs must be held HIGH or LOW. They may not float.

## DC Electrical Characteristics

Symbol	Parameter	V <sub>CC</sub> (V)	Conditions	T <sub>A</sub> = 25°C			T <sub>A</sub> = -40°C to +85°C		Units
				Min.	Typ.	Max.	Min.	Max.	
V <sub>IH</sub>	HIGH Level Input Voltage	4.5		2.0			2.0		V
		5.5		2.0			2.0		
V <sub>IL</sub>	LOW Level Input Voltage	4.5				0.8		0.8	V
		5.5				0.8		0.8	
V <sub>OH</sub>	HIGH Level Output Voltage	4.5	V <sub>IN</sub> = V <sub>IH</sub> or V <sub>IL</sub>	I <sub>OH</sub> = -50μA	4.40	4.50		4.40	V
				I <sub>OH</sub> = -8mA	3.94			3.80	
V <sub>OL</sub>	LOW Level Output Voltage	4.5	V <sub>IN</sub> = V <sub>IH</sub> or V <sub>IL</sub>	I <sub>OL</sub> = 50μA		0.0	0.1	0.1	V
				I <sub>OL</sub> = 8mA			0.36	0.44	
I <sub>OZ</sub>	3-STATE Output Off-State Current	5.5	V <sub>IN</sub> = V <sub>IH</sub> or V <sub>IL</sub> , V <sub>OUT</sub> = V <sub>CC</sub> or GND				±0.25	±2.5	μA
I <sub>IN</sub>	Input Leakage Current	0-5.5	V <sub>IN</sub> = 5.5V or GND				±0.1	±1.0	μA
I <sub>CC</sub>	Quiescent Supply Current	5.5	V <sub>IN</sub> = V <sub>CC</sub> or GND				4.0	40.0	μA
I <sub>CC(T)</sub>	Maximum I <sub>CC</sub> /Input	5.5	V <sub>IN</sub> = 3.4V, Other Inputs = V <sub>CC</sub> or GND				1.35	1.50	mA
I <sub>OFF</sub>	Output Leakage Current (Power Down State)	0.0	V <sub>OUT</sub> = 5.5V				0.5	5.0	μA

## Noise Characteristics

Symbol	Parameter	V <sub>CC</sub> (V)	Conditions	T <sub>A</sub> = 25°C		Units
				Typ.	Limits	
V <sub>OLP</sub> <sup>(6)</sup>	Quiet Output Maximum Dynamic V <sub>OL</sub>	5.0	C <sub>L</sub> = 50pF	1.2	1.6	V
V <sub>OLV</sub> <sup>(6)</sup>	Quiet Output Minimum Dynamic V <sub>OL</sub>	5.0	C <sub>L</sub> = 50pF	-1.2	-1.6	V
V <sub>IHD</sub> <sup>(6)</sup>	Minimum HIGH Level Dynamic Input Voltage	5.0	C <sub>L</sub> = 50pF		2.0	V
V <sub>ILD</sub> <sup>(6)</sup>	Maximum LOW Level Dynamic Input Voltage	5.0	C <sub>L</sub> = 50pF		0.8	V

**Note:**

6. Parameter guaranteed by design.

## AC Electrical Characteristics

Symbol	Parameter	V <sub>CC</sub> (V)	Conditions	T <sub>A</sub> = +25°C			T <sub>A</sub> = -40°C to +85°C		Units
				Min.	Typ.	Max.	Min.	Max.	
t <sub>PLH</sub> , t <sub>PHL</sub>	Propagation Delay Time (LE to O <sub>n</sub> )	5.0 ± 0.5		C <sub>L</sub> = 15pF	7.7	12.3	1.0	13.5	ns
				C <sub>L</sub> = 50pF	8.5	13.3	1.0	14.5	
t <sub>PLH</sub> , t <sub>PHL</sub>	Propagation Delay Time (D to O <sub>n</sub> )	5.0 ± 0.5		C <sub>L</sub> = 15pF	5.1	8.5	1.0	9.5	ns
				C <sub>L</sub> = 50pF	5.9	9.5	1.0	10.5	
t <sub>PZL</sub> , t <sub>PZH</sub>	3-STATE Output Enable Time	5.0 ± 0.5	R <sub>L</sub> = 1kΩ	C <sub>L</sub> = 15pF	6.3	10.9	1.0	12.5	ns
				C <sub>L</sub> = 50pF	7.1	11.9	1.0	13.5	
t <sub>PLZ</sub> , t <sub>PHZ</sub>	3-STATE Output Disable Time	5.0 ± 0.5	R <sub>L</sub> = 1kΩ	C <sub>L</sub> = 50pF	8.8	11.2	1.0	12.0	ns
t <sub>OSLH</sub> , t <sub>OSHL</sub>	Output to Output Skew	5.0 ± 0.5	(7)			1.0		1.0	ns
C <sub>IN</sub>	Input Capacitance		V <sub>CC</sub> = Open		4	10		10	pF
C <sub>OUT</sub>	Output Capacitance		V <sub>CC</sub> = 5.0V		6				pF
C <sub>PD</sub>	Power Dissipation Capacitance		(8)		25				pF

## Notes:

7. Parameter guaranteed by design.  $t_{OSLH} = |t_{PLH \max} - t_{PLH \min}|$ ;  $t_{OSHL} = |t_{PHL \max} - t_{PHL \min}|$
8. C<sub>PD</sub> is defined as the value of the internal equivalent capacitance which is calculated from the operating current consumption without load. Average operating current can be obtained by the equation:  
 $I_{CC}(\text{Opr.}) = C_{PD} \cdot V_{CC} \cdot f_{IN} + I_{CC} / 8$  (per F/F). The total C<sub>PD</sub> when n pcs. of the Latch operates can be calculated by the equation:  $C_{PD}(\text{total}) = 14 + 13n$ .

## AC Operating Requirements

Symbol	Parameter	V <sub>CC</sub> (V)	T <sub>A</sub> = +25°C			T <sub>A</sub> = -40°C to +85°C		Units
			Min.	Typ.	Max.	Min.	Max.	
t <sub>W(H)</sub>	Minimum Pulse Width (LE)	5.0 ± 0.5	6.5			8.5		ns
t <sub>S</sub>	Minimum Set-Up Time	5.0 ± 0.5	1.5			1.5		ns
t <sub>H</sub>	Minimum Hold Time	5.0 ± 0.5	3.5			3.5		ns

### Physical Dimensions

Dimensions are in millimeters unless otherwise noted.

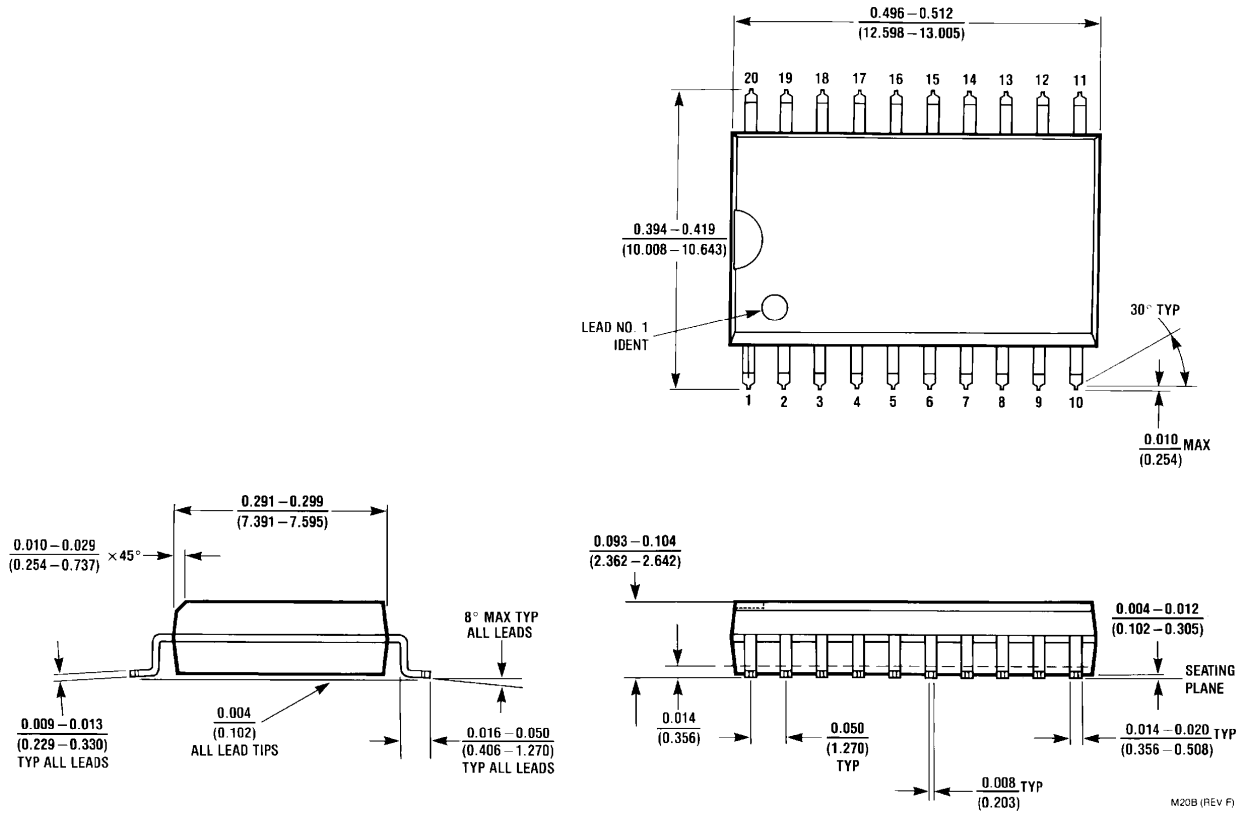
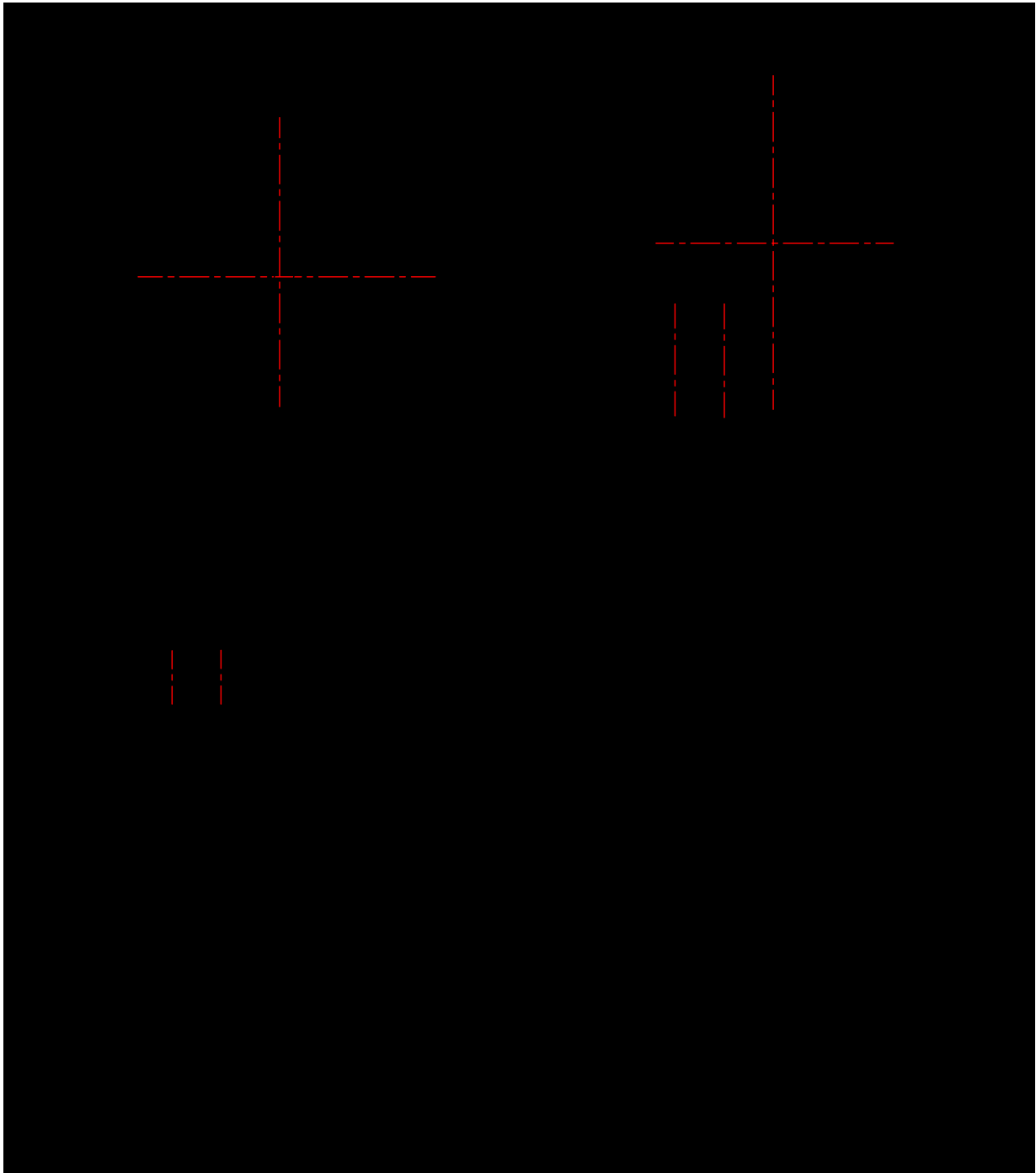

Figure 1. 20-Lead Small Outline Integrated Circuit (SOIC), JEDEC MS-013, 0.300" Wide Package Number M20B

**Physical Dimensions** (Continued)

Dimensions are in millimeters unless otherwise noted.



**Figure 2. 20-Lead Small Outline Package (SOP), EIAJ TYPE II, 5.3mm Wide  
Package Number M20D**

**Physical Dimensions** (Continued)

Dimensions are in millimeters unless otherwise noted.

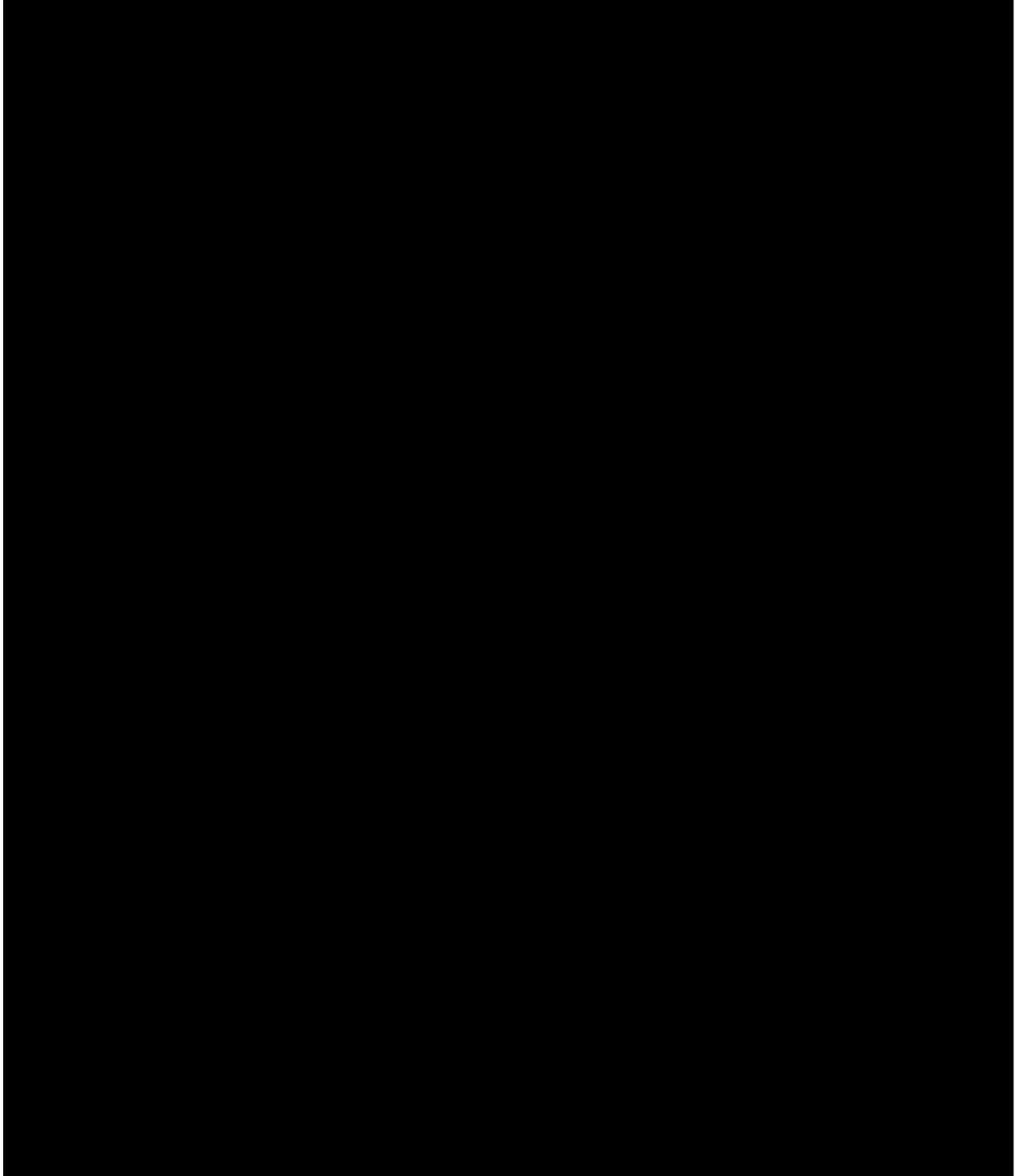

**Figure 3. 20-Lead Thin Shrink Small Outline Package (TSSOP), JEDEC MO-153, 4.4mm Wide  
Package Number MTC20**





15