

# Customer Information Sheet

DRAWING No.: M80-400000FR-XX-XXX-00-000

SHEET 5 OF 8

IF IN DOUBT - ASK

©

NOT TO SCALE

THIRD ANGLE PROJECTION

ALL DIMENSIONS IN mm

## SPECIFICATIONS:

**MATERIAL:**  
 MOULDING: GLASS FILLED PPS, UL94V-0, BLACK  
**COAX CONTACT:**  
 BODY, SLEEVE, INNER CONTACT, END PLUG = COPPER ALLOY  
 LATCHING COLLAR = BERYLLIUM COPPER  
 INSULATOR = PTFE  
 IOILOK SCREW, COLLAR = STAINLESS STEEL  
**FINISH:**  
**COAX CONTACT:**  
 BODY, SLEEVE, INNER CONTACT, END PLUG = GOLD  
 LATCHING COLLAR = NICKEL  
**ELECTRICAL:**  
 WORKING VOLTAGE = 800V AC/DC  
 VOLTAGE PROOF = 1200V AC/DC  
 INSULATION RESISTANCE = 100MΩ MIN  
**COAX CONTACT:**  
 FREQUENCY RANGE = 6GHz  
 IMPEDANCE = 50Ω  
 V.S.W.R = 1.05 + (0.04 x FREQUENCY) GHz MAX  
 CONTACT RESISTANCE = 6mΩ MAX  
 INSULATION RESISTANCE = 10<sup>6</sup>MΩ @ 250V AC  
 OPERATING VOLTAGE = 180V AC @ 500mA  
 MAXIMUM VOLTAGE = 1000V AC  
**MECHANICAL:**  
 DURABILITY = 500 OPERATIONS  
**COAX CONTACT:**  
 INSERTION FORCE = 8N MAX  
 WITHDRAWAL FORCE = 0.5N MIN  
**ENVIRONMENTAL:**  
 TEMPERATURE RANGE = -55°C TO +125°C  
**PACKING:**  
 BAG  
 FOR COMPLETE SPECIFICATION SEE COMPONENT SPECIFICATION C005XX (LATEST ISSUE)

## COAX CRIMP CONTACTS ONLY

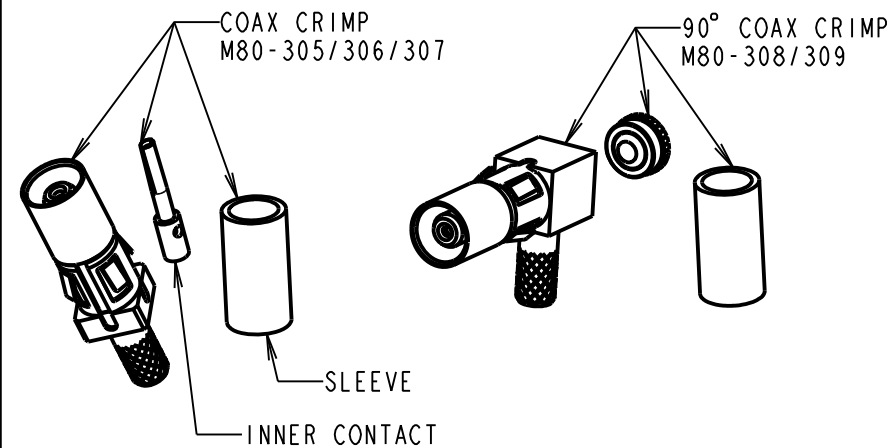
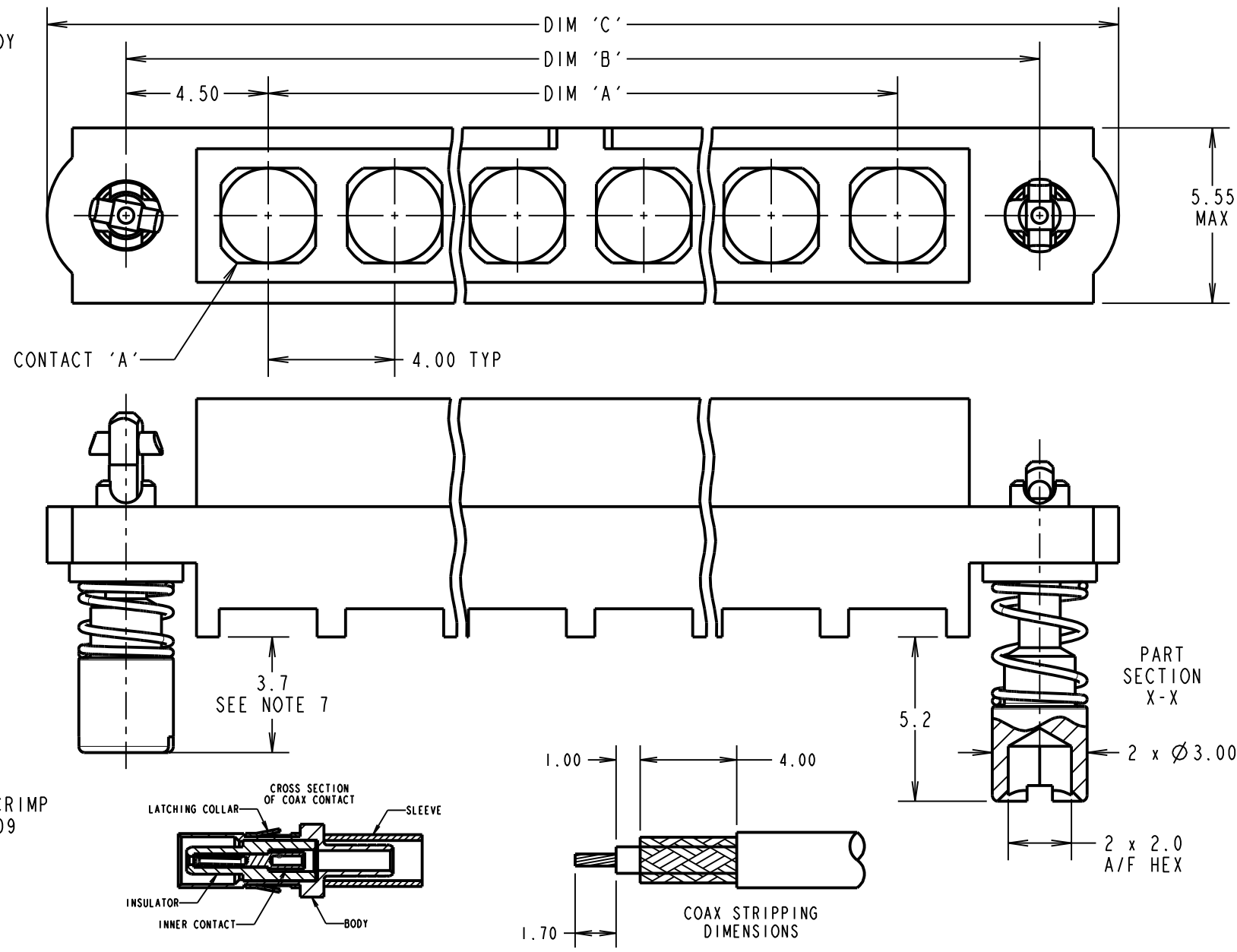

### CRIMP/SOLDER NOTES:

- CONNECTORS ARE SUPPLIED WITH CONTACTS NOT ASSEMBLED.
- COAX CONTACT IS SUPPLIED AS A KIT OF PARTS: BODY, MAIN INSULATOR, INNER CONTACT AND LATCHING COLLAR ARE PRE-ASSEMBLED AND SLEEVE AND INSULATED END PLUG ASSEMBLY ARE SEPARATE.
- FOR EXTRA COAX CONTACTS, USE PART NUMBERS M80-305/~~306~~/307/308/309.
- COAX CONTACT EXTRACTION TOOL = Z80-290.
- RECOMMENDED HAND CRIMP TOOL FOR INNER COAX CONTACT = Z80-292 WITH POSITIONER Z80-291. RECOMMENDED HAND CRIMP TOOL AND DIE SET FOR SLEEVE = Z80-293.
- INSTRUCTION SHEETS ARE AVAILABLE.
- LENGTH WILL BE 3.7mm WHEN IOILOK SCREWS ARE ENGAGED WITH RETAINERS IN MATING CONNECTOR.
- SPRING LOAD WHEN SOLID = 2.642N. SPRING RATE = 1.32N/mm.
- RECOMMENDED PANEL/PCB THICKNESS = 1.3 - 1.6mm.

ORDER CODE: (COAX CRIMP CONTACTS ONLY)

**M80-400000FR-XX-XXX-00-000**

TOTAL No. OF CONTACTS \_\_\_\_\_  
 02 TO 12

### SPECIAL CONTACTS

- 305 = COAX CONTACT 2.00mm CRIMP M80-305
- ~~306 = COAX CONTACT 2.40mm CRIMP M80-306~~
- 307 = COAX CONTACT 2.70mm CRIMP M80-307
- 308 = COAX CONTACT 2.00mm HORIZ' CRIMP M80-308
- 309 = COAX CONTACT 2.70mm HORIZ' CRIMP M80-309

DIMENSION	CALCULATION
DIM 'A'	4 x No. OF CONTACTS - 4.00
DIM 'B'	4 x No. OF CONTACTS + 5.00
DIM 'C'	4 x No. OF CONTACTS + 10.0

EXAMPLE 1: CONNECTOR WITH 08 COAX CONTACTS,  
 M80-400000FR-08-305-00-000  
 DIM 'A' = 28.00mm, DIM 'B' = 37.00mm, DIM 'C' = 42.0mm

# HARWIN

www.harwin.com  
 technical@harwin.com

THIS DRAWING AND ANY INFORMATION OR DESCRIPTIVE MATTER SET OUT HEREON ARE CONFIDENTIAL AND COPYRIGHT PROPERTY OF THE HARWIN GROUP AND MUST NOT BE DISCLOSED, LOANED, COPIED OR USED FOR MANUFACTURING, TENDERING OR FOR ANY OTHER PURPOSE WITHOUT THEIR WRITTEN PERMISSION.

**TOLERANCES**  
 X. = ±1mm  
 X.X = ±0.50mm  
 X.XX = ±0.10mm  
 X.XXX = ±0.01mm  
**ANGLES = ±5°**  
 UNLESS STATED

**MATERIAL:**  
 SEE ABOVE  
**FINISH:** SEE ABOVE  
**S/AREA:** mm<sup>2</sup>

**TITLE:** DATAMATE MIX-TEK FEMALE ASSEMBLY WITH HEX SOCKET IOILOK

**DRAWING NUMBER:** M80-400000FR-XX-XXX-00-000

MGP	5	17.01.18	21020
NAME	ISS.	DATE	C/NOTE
APPROVED: MGP			
CHECKED: SB			
DRAWN: C.PENROSE			
CUSTOMER REF.:			
ASSEMBLY DRG:			

# Customer Information Sheet

DRAWING No.: M80-400000FR-XX-XXX-00-000

SHEET 6 OF 8

IF IN DOUBT - ASK

©

NOT TO SCALE

THIRD ANGLE PROJECTION

ALL DIMENSIONS IN mm

## SPECIFICATIONS:

**MATERIAL:**  
 MOULDING: GLASS FILLED PPS, UL94V-0, BLACK  
**POWER CONTACT:**  
 BODY, SLEEVE, INNER CONTACT, END PLUG = COPPER ALLOY  
 LATCHING COLLAR = BERYLLIUM COPPER  
 INSULATOR = PTFE  
 IOILOK SCREW, COLLAR = STAINLESS STEEL  
**FINISH:**  
**POWER CONTACT:**  
 BODY, SLEEVE, INNER CONTACT, END PLUG = GOLD  
 LATCHING COLLAR = NICKEL  
**ELECTRICAL:**  
 WORKING VOLTAGE = 800V AC/DC  
 VOLTAGE PROOF = 1200V AC/DC  
 INSULATION RESISTANCE = 100MΩ MIN  
**POWER CONTACT:**  
 CONTACT RESISTANCE = 6mΩ MAX  
 CURRENT RATING = M80-325 = 20A MAX WITH 12AWG  
 M80-326 = 15A MAX WITH 14AWG  
 M80-327 = 10A MAX WITH 16AWG  
 M80-328 = 8A MAX WITH 18AWG  
 M80-329 = 5A MAX WITH 20AWG  
 M80-32A = 20A MAX WITH 12AWG  
 M80-32B = 15A MAX WITH 14AWG  
 M80-32C = 10A MAX WITH 16AWG  
 M80-PF5 = 40A MAX WITH 10AWG  
 CONTACT AS SPECIFIED

**MECHANICAL:**  
 DURABILITY = 500 OPERATIONS  
**POWER CONTACT:**  
 INSERTION FORCE:  
 M80-325/326/327/328/329/  
 32A/32B/32C = 8N MAX  
 M80-PF5 = 15N MAX  
 WITHDRAWAL FORCE = 0.5N MIN  
**ENVIRONMENTAL:**  
 TEMPERATURE RANGE:  
 M80-325/326/327/328/329/  
 32A/32B/32C = -55°C TO +125°C  
 M80-PF5 = -55°C TO +150°C  
**PACKING:**  
 BAG  
 FOR COMPLETE SPECIFICATION SEE COMPONENT  
 SPECIFICATION C005XX (LATEST ISSUE)

## POWER CRIMP & SOLDER CONTACTS ONLY

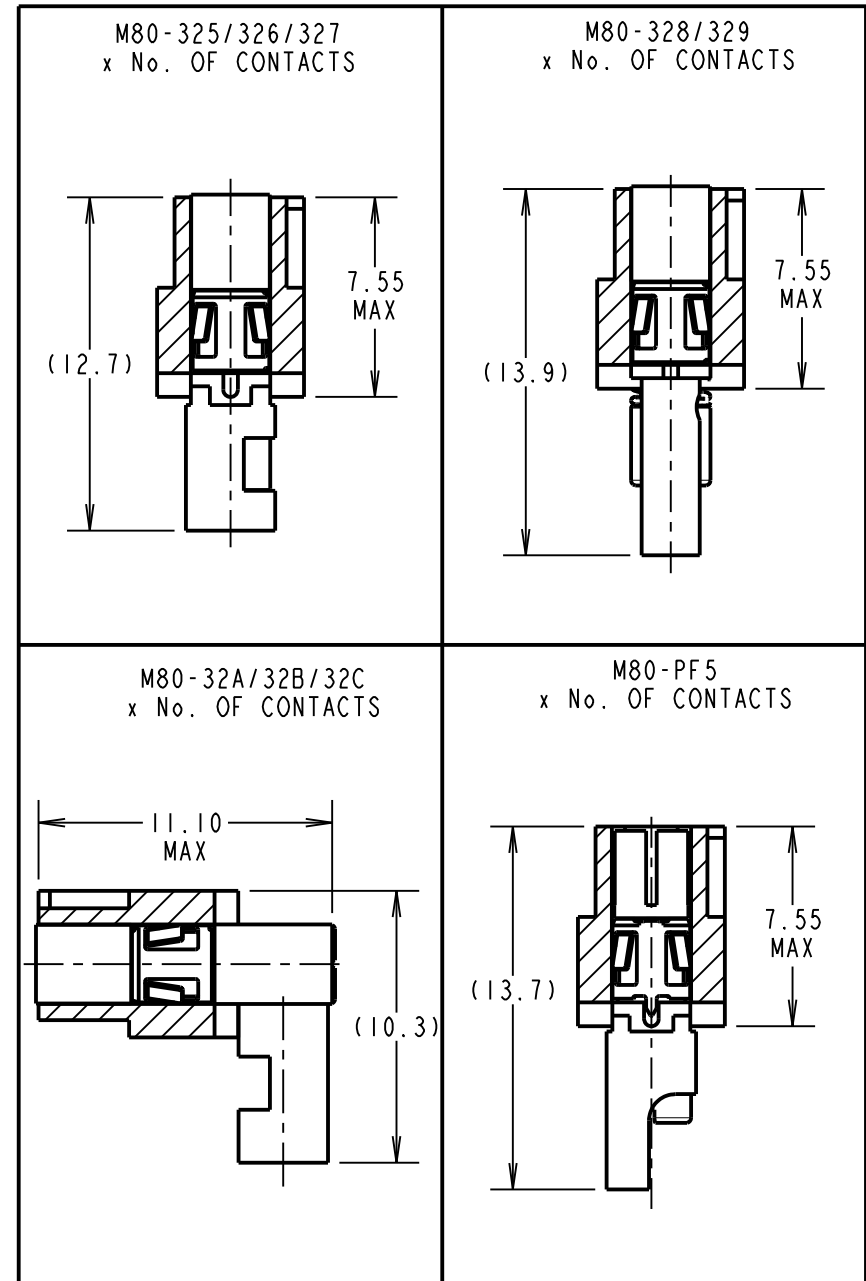
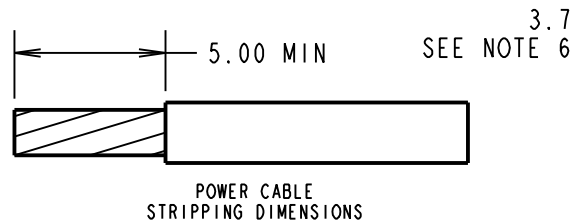
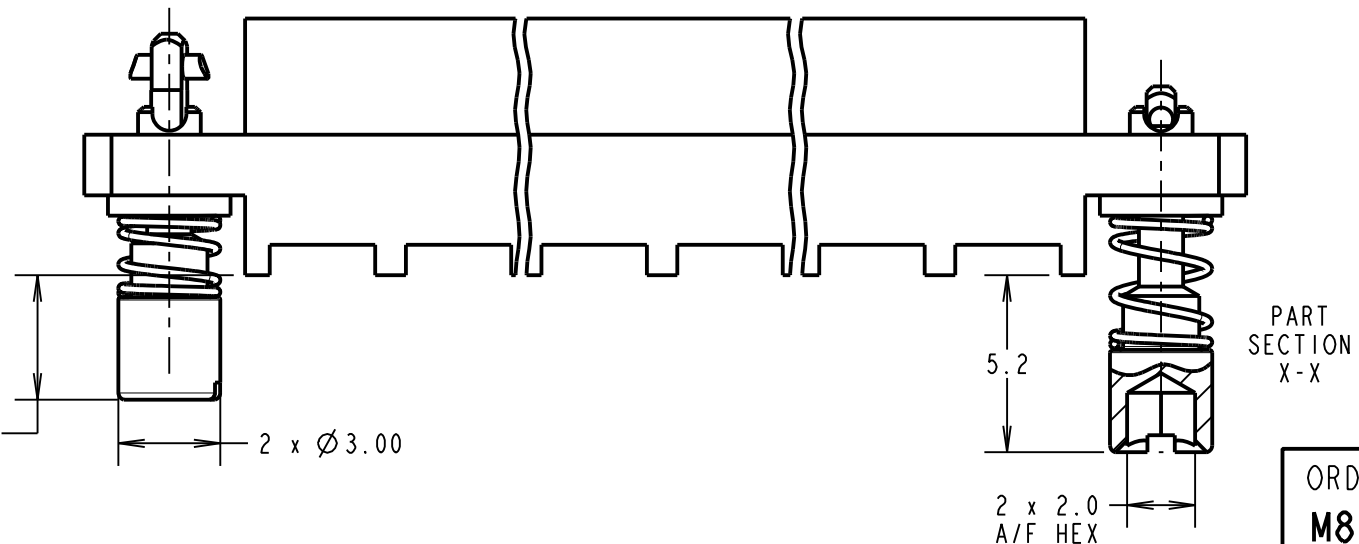
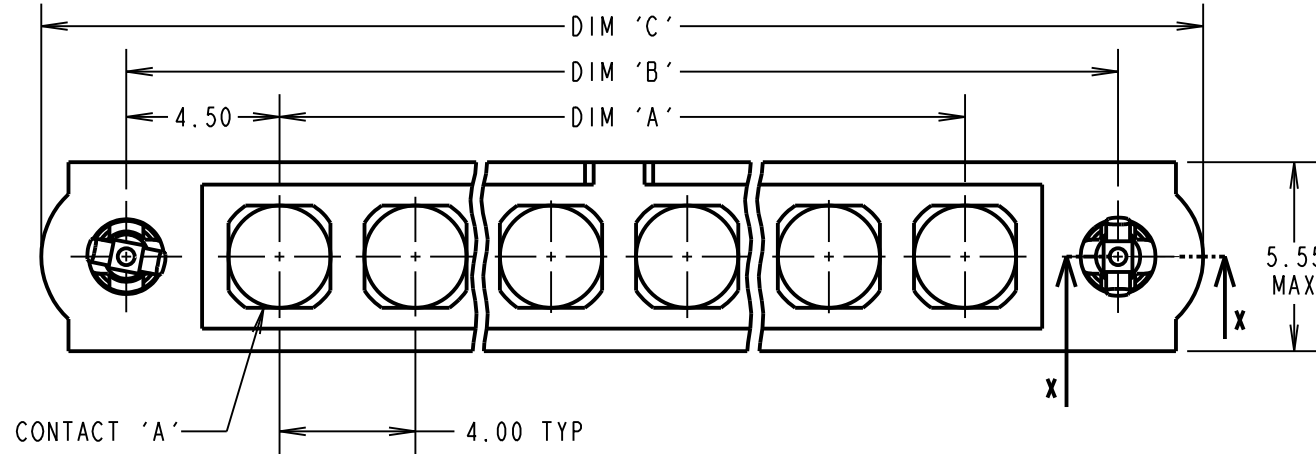

- CRIMP/SOLDER NOTES:**
- CONNECTORS ARE SUPPLIED WITH CONTACTS NOT ASSEMBLED.
  - FOR EXTRA POWER CONTACTS USE PART NUMBERS M80-325/326/327/328/329/32A/32B/32C/PM5.
  - POWER CONTACT EXTRACTION TOOL = Z80-290.
  - RECOMMENDED HAND CRIMP TOOL FOR CONTACTS 328/329 = Z80-294 AND POSITIONER Z80-295.
  - INSTRUCTION SHEETS ARE AVAILABLE.
  - LENGTH WILL BE 3.7mm WHEN IOILOK SCREWS ARE ENGAGED WITH RETAINERS IN MATING CONNECTOR.
  - SPRING LOAD WHEN SOLID = 2.642N. SPRING RATE = 1.32N/mm.
  - RECOMMENDED PANEL/PCB THICKNESS = 1.3 - 1.6mm.

ORDER CODE: (POWER CRIMP/SOLDER CONTACTS ONLY)  
**M80-400000FR-XX-XXX-00-000**

TOTAL No. OF CONTACTS \_\_\_\_\_  
 02 TO 12

**SPECIAL CONTACTS**

- 325 = POWER CONTACT 12AWG SOLDER M80-325
- 326 = POWER CONTACT 14AWG SOLDER M80-326
- 327 = POWER CONTACT 16AWG SOLDER M80-327
- 328 = POWER CONTACT 18AWG SOLDER/CRIMP M80-328
- 329 = POWER CONTACT 20AWG SOLDER/CRIMP M80-329
- 32A = POWER CONTACT 12AWG HORIZ' SOLDER M80-32A
- 32B = POWER CONTACT 14AWG HORIZ' SOLDER M80-32B
- 32C = POWER CONTACT 16AWG HORIZ' SOLDER M80-32C
- PF5 = POWER CONTACT 10AWG SOLDER M80-PF5

MGP	5	17.01.18	21020
NAME	ISS.	DATE	C/NOTE
APPROVED: MGP			
CHECKED: SB			
DRAWN: C.PENROSE			
CUSTOMER REF.:			
ASSEMBLY DRG:			

DIMENSION	CALCULATION
DIM 'A'	4 x No. OF CONTACTS - 4.00
DIM 'B'	4 x No. OF CONTACTS + 5.00
DIM 'C'	4 x No. OF CONTACTS + 10.0

EXAMPLE 2: CONNECTOR WITH 10 POWER CONTACTS,  
 M80-400000FR-10-325-00-000  
 DIM 'A' = 36.00mm, DIM 'B' = 45.00mm, DIM 'C' = 50.0mm



THIS DRAWING AND ANY INFORMATION OR DESCRIPTIVE MATTER SET OUT HEREON ARE CONFIDENTIAL AND COPYRIGHT PROPERTY OF THE HARWIN GROUP AND MUST NOT BE DISCLOSED, LOANED, COPIED OR USED FOR MANUFACTURING, TENDERING OR FOR ANY OTHER PURPOSE WITHOUT THEIR WRITTEN PERMISSION.

**TOLERANCES**  
 X. = ±1mm  
 X.X = ±0.50mm  
 X.XX = ±0.10mm  
 X.XXX = ±0.01mm  
**ANGLES = ±5°**  
 UNLESS STATED

**MATERIAL:**  
 SEE ABOVE  
**FINISH:** SEE ABOVE  
**S/AREA:** mm<sup>2</sup>

**TITLE:** DATAMATE MIX-TEK FEMALE ASSEMBLY WITH HEX SOCKET IOILOK  
**DRAWING NUMBER:** M80-400000FR-XX-XXX-00-000  
 SHT 6 OF 8

# Customer Information Sheet

DRAWING No.: M80-400000FR-XX-XXX-00-000

SHEET 7 OF 8

IF IN DOUBT - ASK

©

NOT TO SCALE

THIRD ANGLE PROJECTION

ALL DIMENSIONS IN mm

RECOMMENDED PCB LAYOUT FOR POWER CONTACTS: M80-321/322

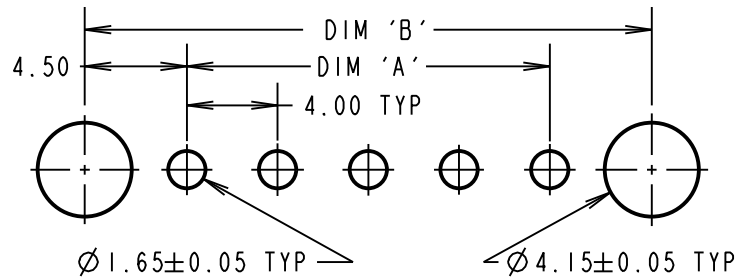

RECOMMENDED PCB LAYOUT FOR COAX CONTACTS: M80-301/302

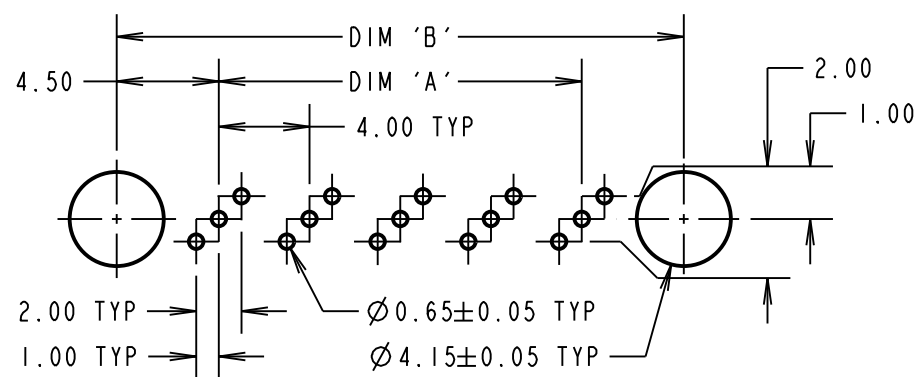

- SPECIFICATIONS:**  
**MATERIAL:**  
 MOULDING: GLASS FILLED PPS, UL94V-0, BLACK  
 POWER CONTACT: COPPER ALLOY  
 COAX CONTACT:  
 BODY = COPPER ALLOY  
 INNER CONTACT = COPPER ALLOY  
 INSULATOR = PTFE  
 IOILOK SCREW, COLLAR = STAINLESS STEEL  
**FINISH:**  
 POWER CONTACT: GOLD  
 COAX CONTACT: BODY, INNER CONTACT = GOLD  
**ELECTRICAL:**  
 WORKING VOLTAGE = 800V AC/DC  
 VOLTAGE PROOF = 1200V AC/DC  
 INSULATION RESISTANCE = 100MΩ MIN  
 POWER CONTACT:  
 CONTACT RESISTANCE = 6mΩ MAX  
 CURRENT RATING:  
 M80-321/322 = 20A MAX  
 M80-PF1/PF2 = 40A MAX  
 COAX CONTACT:  
 FREQUENCY RANGE = 6GHz  
 IMPEDANCE = 50Ω  
 V.S.W.R = 1.05 + (0.04 x FREQUENCY) GHz MAX  
 CONTACT RESISTANCE = 6mΩ MAX  
 INSULATION RESISTANCE = 10<sup>6</sup>MΩ @ 250V AC  
 OPERATING VOLTAGE = 180V AC @ 500mA  
 MAXIMUM VOLTAGE = 1000V AC  
**MECHANICAL:**  
 DURABILITY = 500 OPERATIONS  
 POWER CONTACT:  
 INSERTION FORCE:  
 M80-321/322 = 8N MAX  
 M80-PF1/PF2 = 15N MAX  
 WITHDRAWAL FORCE = 0.5N MIN  
 COAX CONTACT:  
 INSERTION FORCE = 8N MAX  
 WITHDRAWAL FORCE = 0.5N MIN  
**ENVIRONMENTAL:**  
 TEMPERATURE RANGE:  
 M80-301/302/321/322 = -55°C TO +125°C  
 M80-PF1/PF2 = -55°C TO +150°C  
**PACKING:**  
 TUBE  
 FOR COMPLETE SPECIFICATION SEE COMPONENT SPECIFICATION C005XX (LATEST ISSUE)

## VERTICAL PC TAIL CONTACTS ONLY

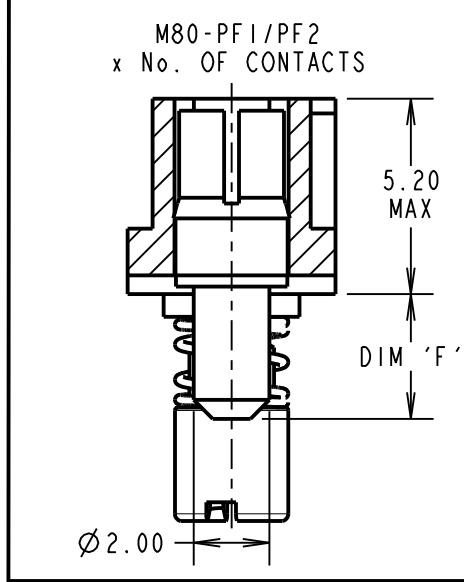
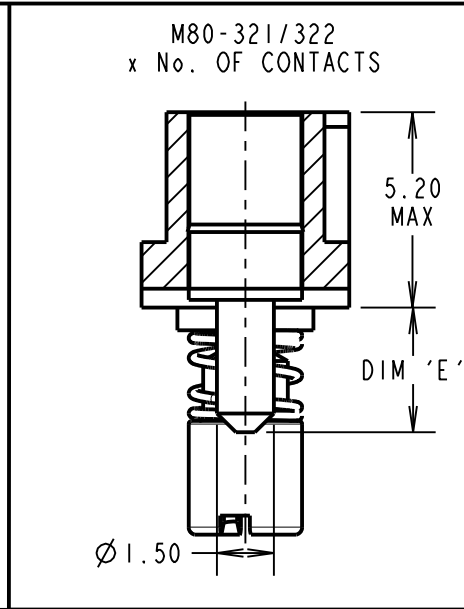
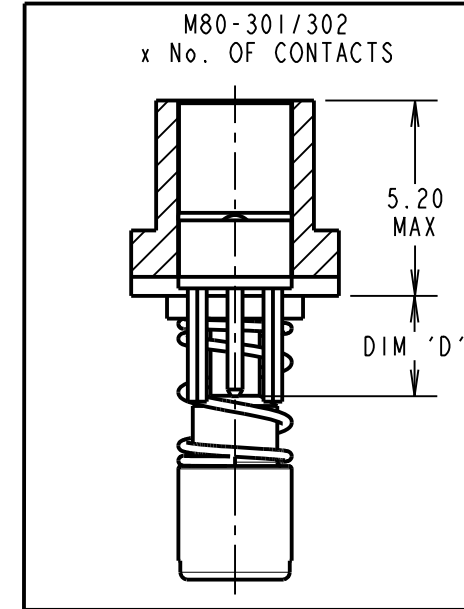
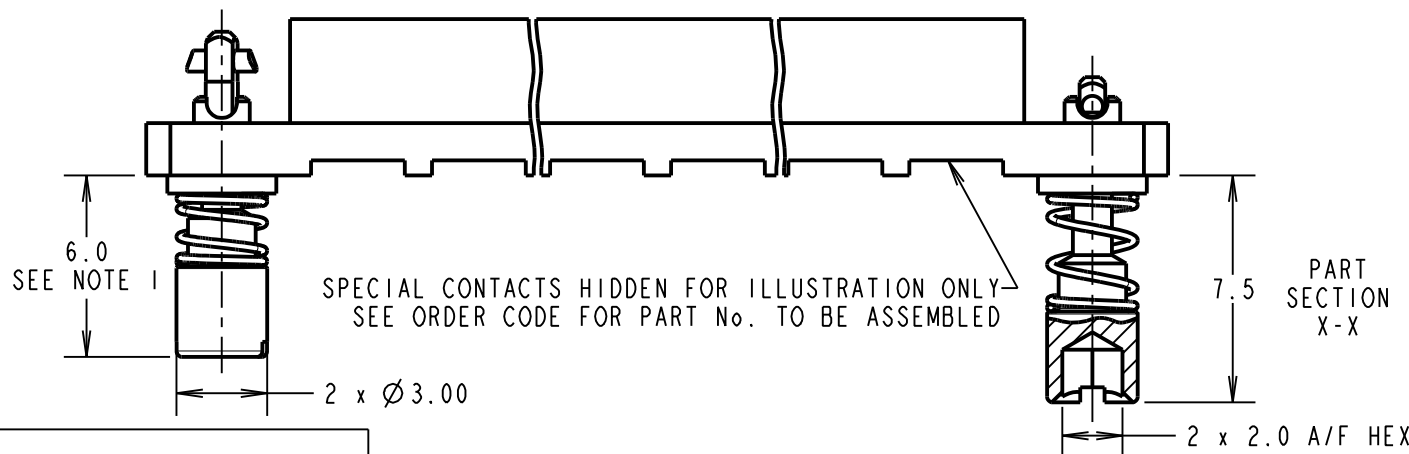
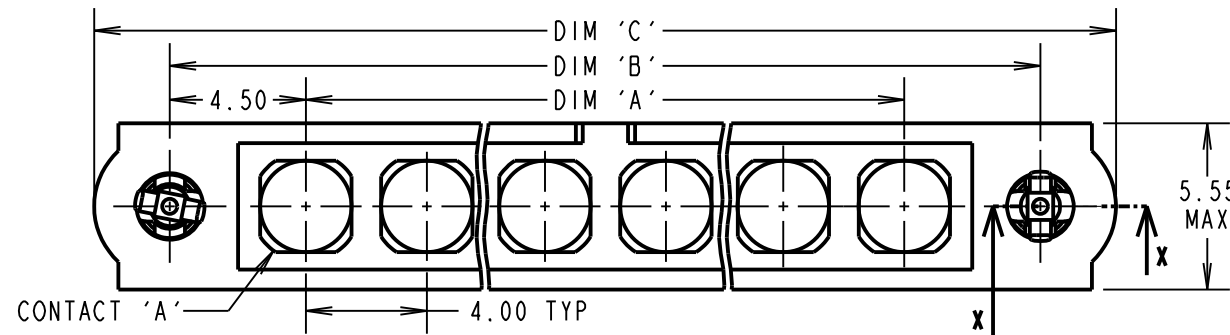

- NOTES:**  
 1. LENGTH WILL BE 6.0mm WHEN IOILOK SCREWS ARE ENGAGED WITH RETAINERS IN MATING CONNECTOR.  
 2. SPRING LOAD WHEN SOLID = 2.642N. SPRING RATE = 1.32N/mm.

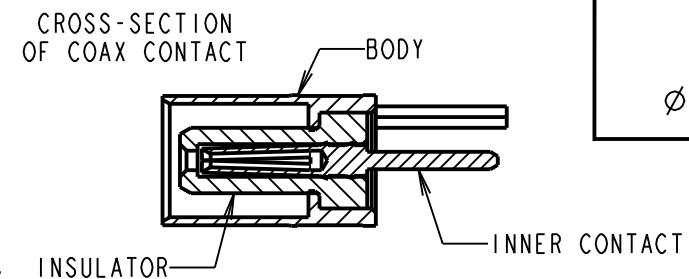

RECOMMENDED PCB LAYOUT FOR POWER CONTACTS: M80-PF1/PF2

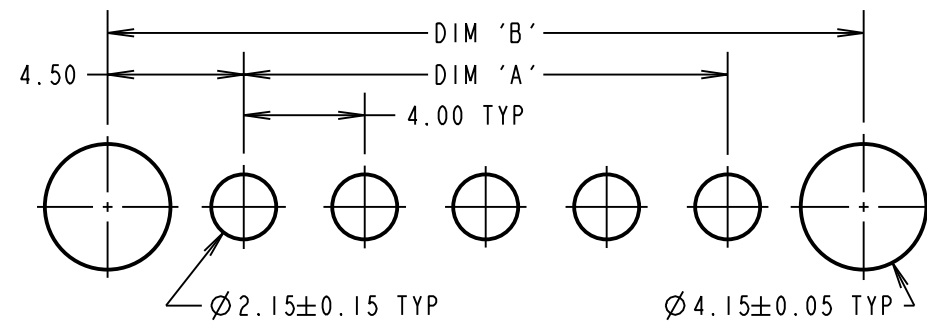

DIMENSION	CALCULATION
DIM 'A'	4 x No. OF CONTACTS - 4.00
DIM 'B'	4 x No. OF CONTACTS + 5.00
DIM 'C'	4 x No. OF CONTACTS + 10.0
DIM 'D'	M80-301 = 3.0mm, M80-302 = 4.5mm
DIM 'E'	M80-321 = 3.5mm, M80-322 = 5.0mm
DIM 'F'	M80-PF1 = 3.5mm, M80-PF2 = 5.0mm

ORDER CODE: (PC TAIL CONTACTS ONLY)  
**M80-400000FR-XX-XXX-00-000**  
 TOTAL No. OF CONTACTS \_\_\_\_\_  
 02 TO 12 \_\_\_\_\_  
 SPECIAL CONTACTS \_\_\_\_\_  
 301 = COAX CONTACT 3.0mm PC TAIL M80-301  
 302 = COAX CONTACT 4.5mm PC TAIL M80-302  
 321 = 20A POWER CONTACT 3.5mm VERT' PC TAIL M80-321  
 322 = 20A POWER CONTACT 5.0mm VERT' PC TAIL M80-322  
 PF1 = 40A POWER CONTACT 3.5mm VERT' PC TAIL M80-PF1  
 PF2 = 40A POWER CONTACT 5.0mm VERT' PC TAIL M80-PF2

EXAMPLE 1: CONNECTOR WITH 08 COAX CONTACTS,  
 M80-400000FR-08-301-00-000  
 DIM 'A' = 28.00mm, DIM 'B' = 37.00mm, DIM 'C' = 42.0mm  
 DIM 'D' = 3.0mm

EXAMPLE 2: CONNECTOR WITH 10 POWER CONTACTS,  
 M80-400000FR-10-PF1-00-000  
 DIM 'A' = 36.00mm, DIM 'B' = 45.00mm, DIM 'C' = 50.0mm  
 DIM 'F' = 3.5mm

**HARWIN**  
 www.harwin.com  
 technical@harwin.com

THIS DRAWING AND ANY INFORMATION OR DESCRIPTIVE MATTER SET OUT HEREON ARE CONFIDENTIAL AND COPYRIGHT PROPERTY OF THE HARWIN GROUP AND MUST NOT BE DISCLOSED, LOANED, COPIED OR USED FOR MANUFACTURING, TENDERING OR FOR ANY OTHER PURPOSE WITHOUT THEIR WRITTEN PERMISSION.

**TOLERANCES**  
 X. = ±1mm  
 X.X = ±0.50mm  
 X.XX = ±0.10mm  
 X.XXX = ±0.01mm  
 ANGLES = ±5°  
 UNLESS STATED

**MATERIAL:**  
 SEE ABOVE  
**FINISH:**  
 SEE ABOVE  
**S/AREA:**  
 mm<sup>2</sup>

**TITLE:**  
 DATAMATE MIX-TEK FEMALE ASSEMBLY WITH HEX SOCKET IOILOK  
**DRAWING NUMBER:**  
**M80-400000FR-XX-XXX-00-000**  
 SHT 7 OF 8

MGP	5	17.01.18	21020
NAME	ISS.	DATE	C/NOTE
APPROVED: MGP			
CHECKED: SB			
DRAWN: C.PENROSE			
CUSTOMER REF.:			
ASSEMBLY DRG:			

# Customer Information Sheet

DRAWING No.: M80-400000FR-XX-XXX-00-000

SHEET 8 OF 8

IF IN DOUBT - ASK

©

NOT TO SCALE

THIRD ANGLE PROJECTION

ALL DIMENSIONS IN mm

## SPECIFICATIONS:

### MATERIAL:

MOULDING: GLASS FILLED PPS, UL94V-0, BLACK  
POWER CONTACT: COPPER ALLOY

### COAX CONTACT:

BODY = COPPER ALLOY  
INNER CONTACT = COPPER ALLOY  
INSULATOR = PTFE

10ILOK SCREW, COLLAR = STAINLESS STEEL

### FINISH:

POWER CONTACT: GOLD  
COAX CONTACT: BODY, INNER CONTACT = GOLD

### ELECTRICAL:

WORKING VOLTAGE = 800V AC/DC  
VOLTAGE PROOF = 1200V AC/DC  
INSULATION RESISTANCE = 100MΩ MIN

### POWER CONTACT:

CONTACT RESISTANCE = 6mΩ MAX

### CURRENT RATING:

M80-323/324 = 20A MAX  
M80-PF3/PF4 = 40A MAX

### MECHANICAL:

DURABILITY = 500 OPERATIONS

### POWER CONTACT:

INSERTION FORCE:  
M80-323/324 = 8N MAX  
M80-PF3/PF4 = 15N MAX  
WITHDRAWAL FORCE = 0.5N MIN

### ENVIRONMENTAL:

TEMPERATURE RANGE:  
M80-323/324 = -55°C TO +125°C  
M80-PF3/PF4 = -55°C TO +150°C

### PACKING:

TUBE

FOR COMPLETE SPECIFICATION SEE COMPONENT SPECIFICATION C005XX (LATEST ISSUE)

### NOTES:

- LENGTH WILL BE 6.0mm WHEN 10ILOK SCREWS ARE ENGAGED WITH RETAINERS IN MATING CONNECTOR.
- SPRING LOAD WHEN SOLID = 2.642N. SPRING RATE = 1.32N/mm.

RECOMMENDED PCB LAYOUT FOR POWER CONTACTS: M80-PF3/PF4

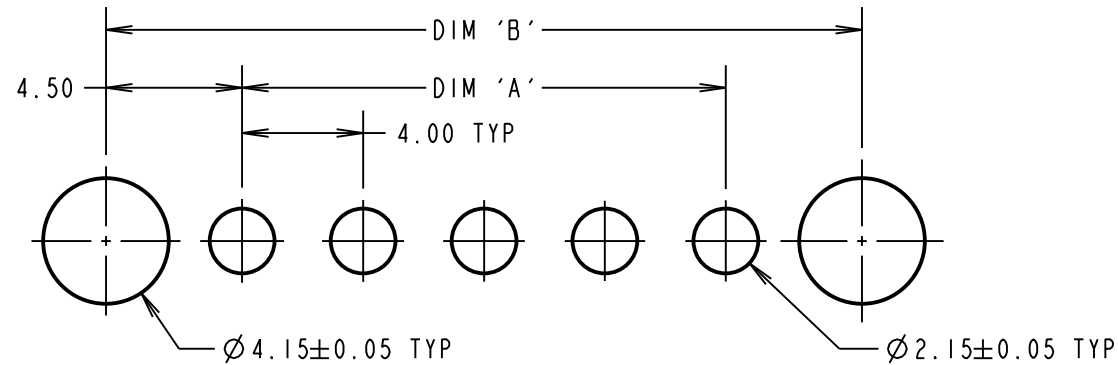

HORIZONTAL PC TAIL & SMT CONTACTS ONLY

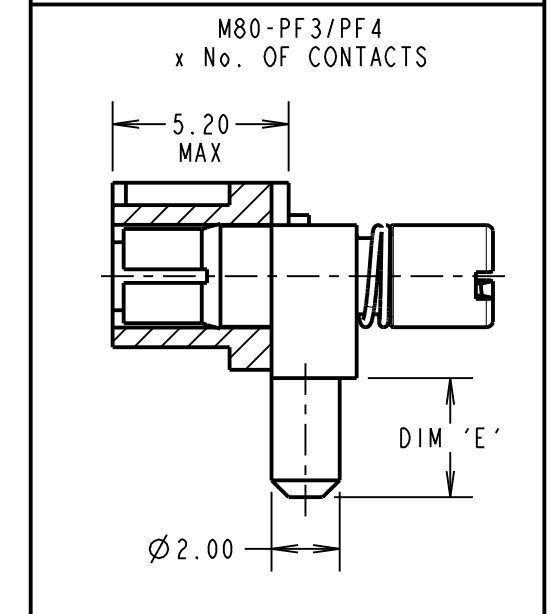
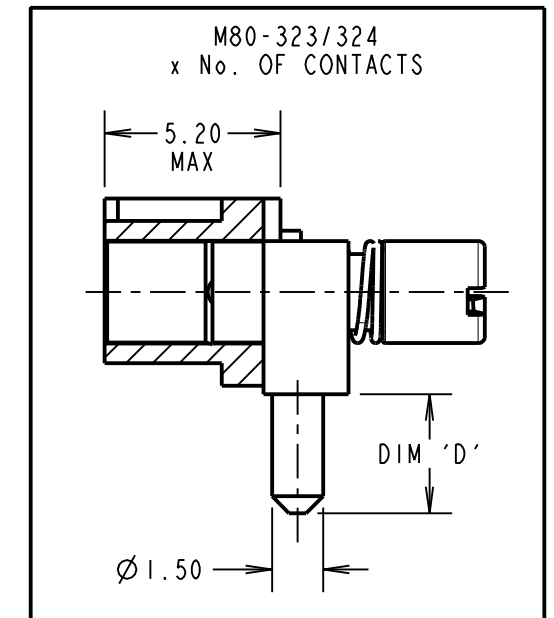
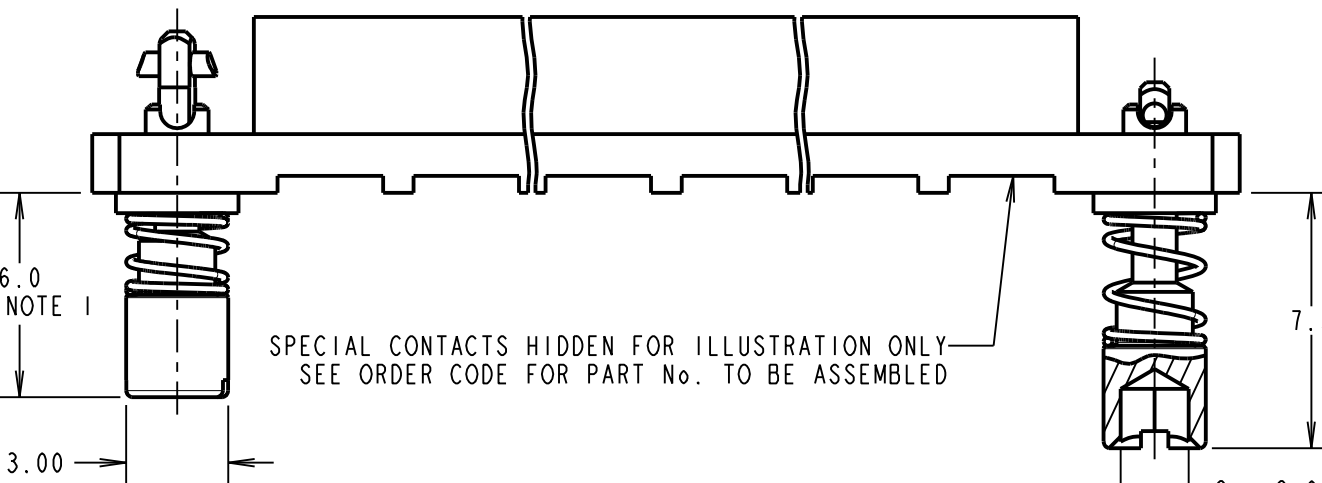
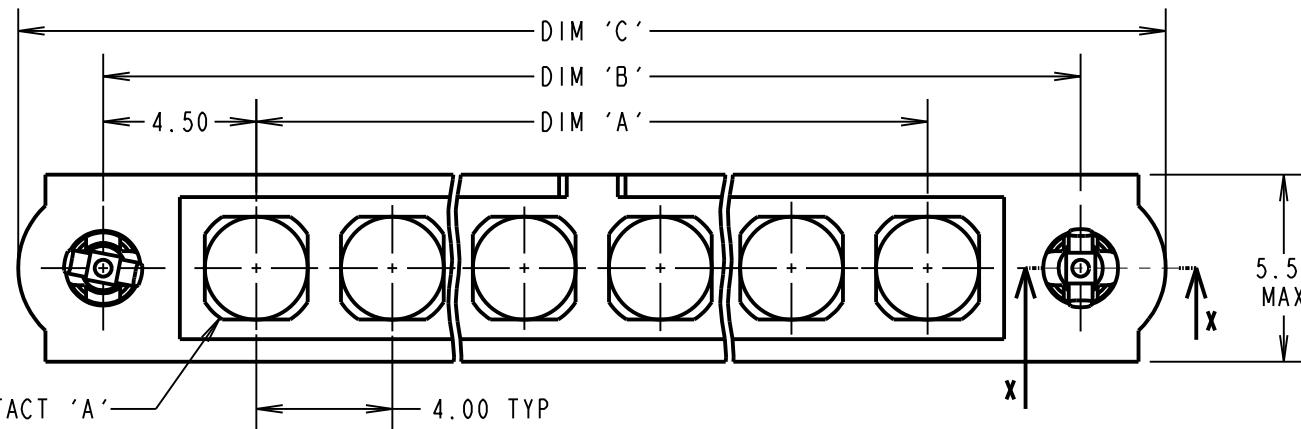

RECOMMENDED PCB LAYOUT FOR POWER CONTACTS: M80-323/324

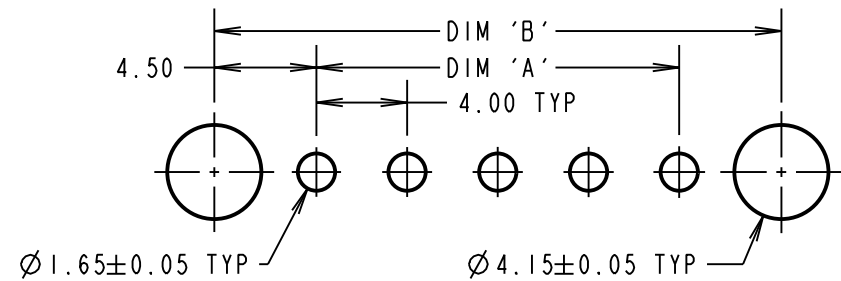

DIMENSION	CALCULATION
DIM 'A'	4 x No. OF CONTACTS - 4.00
DIM 'B'	4 x No. OF CONTACTS + 5.00
DIM 'C'	4 x No. OF CONTACTS + 10.0
DIM 'D'	M80-323 = 3.5mm, M80-324 = 5.0mm
DIM 'E'	M80-PF3 = 3.5mm, M80-PF4 = 5.0mm

EXAMPLE 2: CONNECTOR WITH 10 POWER CONTACTS,  
M80-400000FR-10-323-00-000  
DIM 'A' = 36.00mm, DIM 'B' = 45.00mm, DIM 'C' = 50.0mm  
DIM 'E' = 3.5mm

ORDER CODE: (PC TAIL CONTACTS ONLY)  
**M80-400000FR-XX-XXX-00-000**

TOTAL No. OF CONTACTS  
02 TO 12

### SPECIAL CONTACTS

323 = 20A POWER CONTACT 3.5mm HORZ' PC TAIL M80-323  
324 = 20A POWER CONTACT 5.0mm HORZ' PC TAIL M80-324  
PF3 = 40A POWER CONTACT 3.5mm HORZ' PC TAIL M80-PF3  
PF4 = 40A POWER CONTACT 5.0mm HORZ' PC TAIL M80-PF4

**HARWIN**

www.harwin.com  
technical@harwin.com

THIS DRAWING AND ANY INFORMATION OR DESCRIPTIVE MATTER SET OUT HEREON ARE CONFIDENTIAL AND COPYRIGHT PROPERTY OF THE HARWIN GROUP AND MUST NOT BE DISCLOSED, LOANED, COPIED OR USED FOR MANUFACTURING, TENDERING OR FOR ANY OTHER PURPOSE WITHOUT THEIR WRITTEN PERMISSION.

TOLERANCES  
X. = ±1mm  
X.X = ±0.50mm  
X.XX = ±0.10mm  
X.XXX = ±0.01mm  
ANGLES = ±5°  
UNLESS STATED

### MATERIAL:

SEE ABOVE

### FINISH:

SEE ABOVE

### S/AREA:

mm<sup>2</sup>

### TITLE:

DATAMATE MIX-TEK  
FEMALE ASSEMBLY WITH  
HEX SOCKET 10ILOK

### DRAWING NUMBER:

**M80-400000FR-XX-XXX-00-000**

MGP	5	17.01.18	21020
NAME	ISS.	DATE	C/NOTE
APPROVED: MGP			
CHECKED: SB			
DRAWN: C.PENROSE			
CUSTOMER REF.:			
ASSEMBLY DRG:			

SHT  
8 OF 8