

Product Specification

NHD-C0220BiZ-FS(RGB)-FBW-3VM

COG (Chip-On-Glass) Character Liquid Crystal Display Module

NHD-	Newhaven Display
C0220-	COG, 2 Lines x 20 Characters
BiZ-	Model, I2C Interface
F-	Transflective
S(RGB)-	Side LED Backlights- Red, Green, and Blue
F-	FSTN (+)
B-	6:00 Optimal View
W-	Wide Temperature
3V-	3.3V LCD
M-	Mounting Holes

Table of Contents

Document Revision History.....	2
Mechanical Drawing	3
Pin Description	5
Wiring Diagram	5
Electrical Characteristics	6
Optical Characteristics	6
Controller Information.....	6
DDRAM Address	6
Table of Commands	8
Timing Characteristics.....	10
Built-in Font Table (OPR1 = 0, OPR2 = 0).....	11
Example Initialization Program	12
Quality Information	14

Additional Resources

- **Support Forum:** <https://support.newhavendisplay.com/hc/en-us/community/topics>
- **GitHub:** <https://github.com/newhavendisplay>
- **Example Code:** <https://support.newhavendisplay.com/hc/en-us/categories/4409527834135-Example-Code/>
- **Knowledge Center:** https://www.newhavendisplay.com/knowledge_center.html
- **Quality Center:** https://www.newhavendisplay.com/quality_center.html
- **Precautions for using LCDs/LCMs:** <https://www.newhavendisplay.com/specs/precautions.pdf>
- **Warranty / Terms & Conditions:** <https://www.newhavendisplay.com/terms.html>



Document Revision History

Revision	Date	Description	Changed By
0	07/08/2009	Initial Release	CL
1	07/10/2009	Mechanical Drawing updated	BE
2	09/08/2009	Backlight Supply Current	BE
3	10/09/2009	Updated Electrical Characteristics	MC
4	12/09/2009	Updated Backlight Power Supply and Current	MC
5	05/27/2011	Display Character Address Code Updated	AK
6	06/13/2011	Electrical Characteristics Updated	AK
7	06/23/2014	Mechanical, Electrical & Optical Characteristics Updated	ML
8	05/24/2017	Mechanical, Electrical Characteristics Updated	SB
9	03/20/2018	Mechanical Drawing Updated	SB
10	06/24/2019	Added PCB Footprint Drawing	AS
11	10/23/2020	Updated Symbol for LCD Supply Voltage	AS
12	11/09/2021	Updated Wiring Diagram to match in Positions on Drawings	CJ
13	02/13/2023	Updated the Mechanical Drawing, Electrical Characteristics, Optical Characteristics and Quality Information	KL

Mechanical Drawing

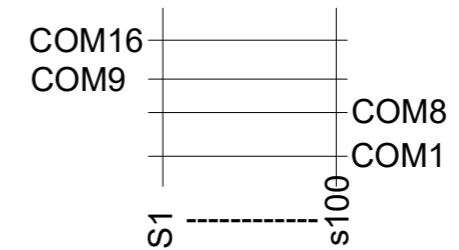
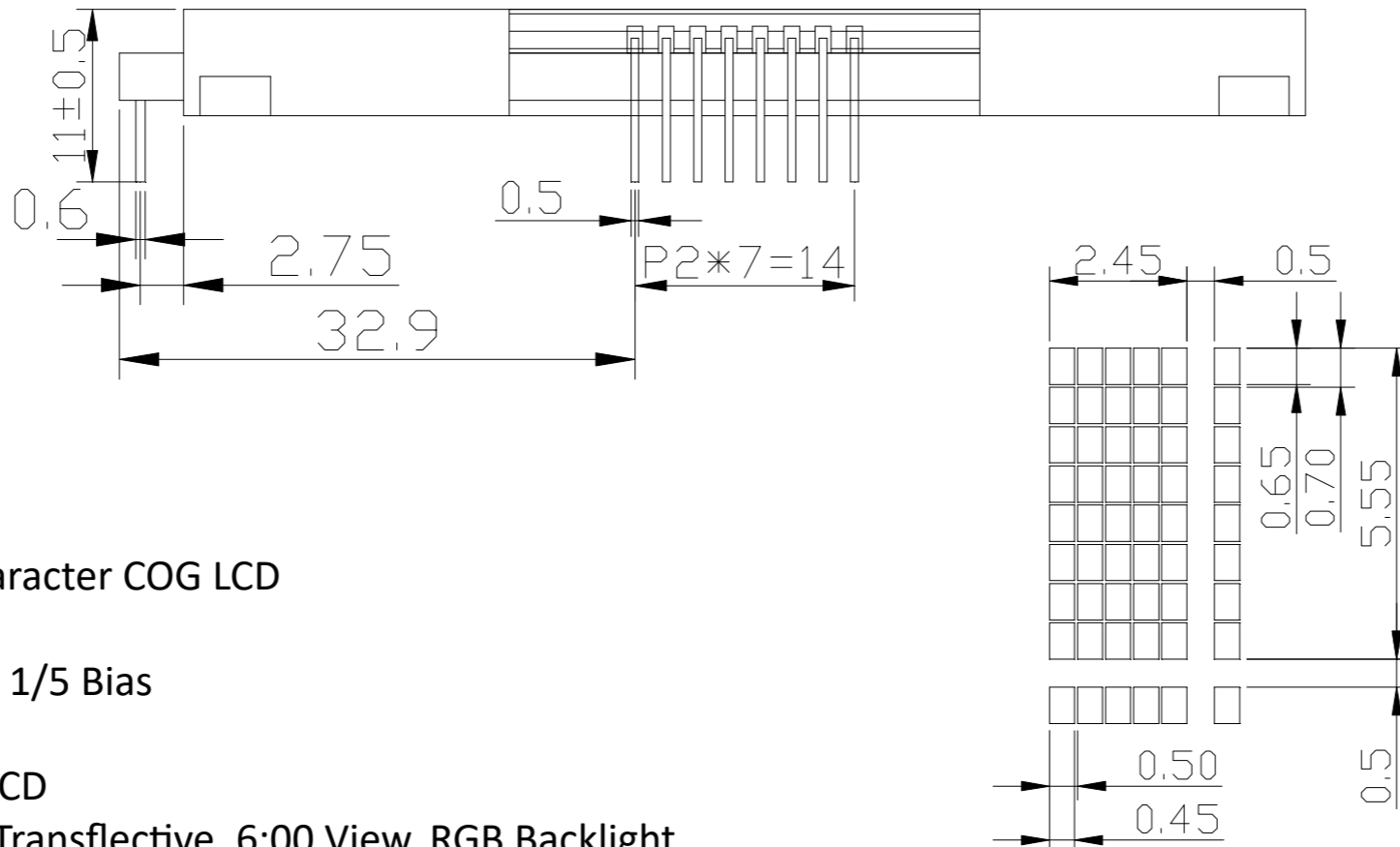
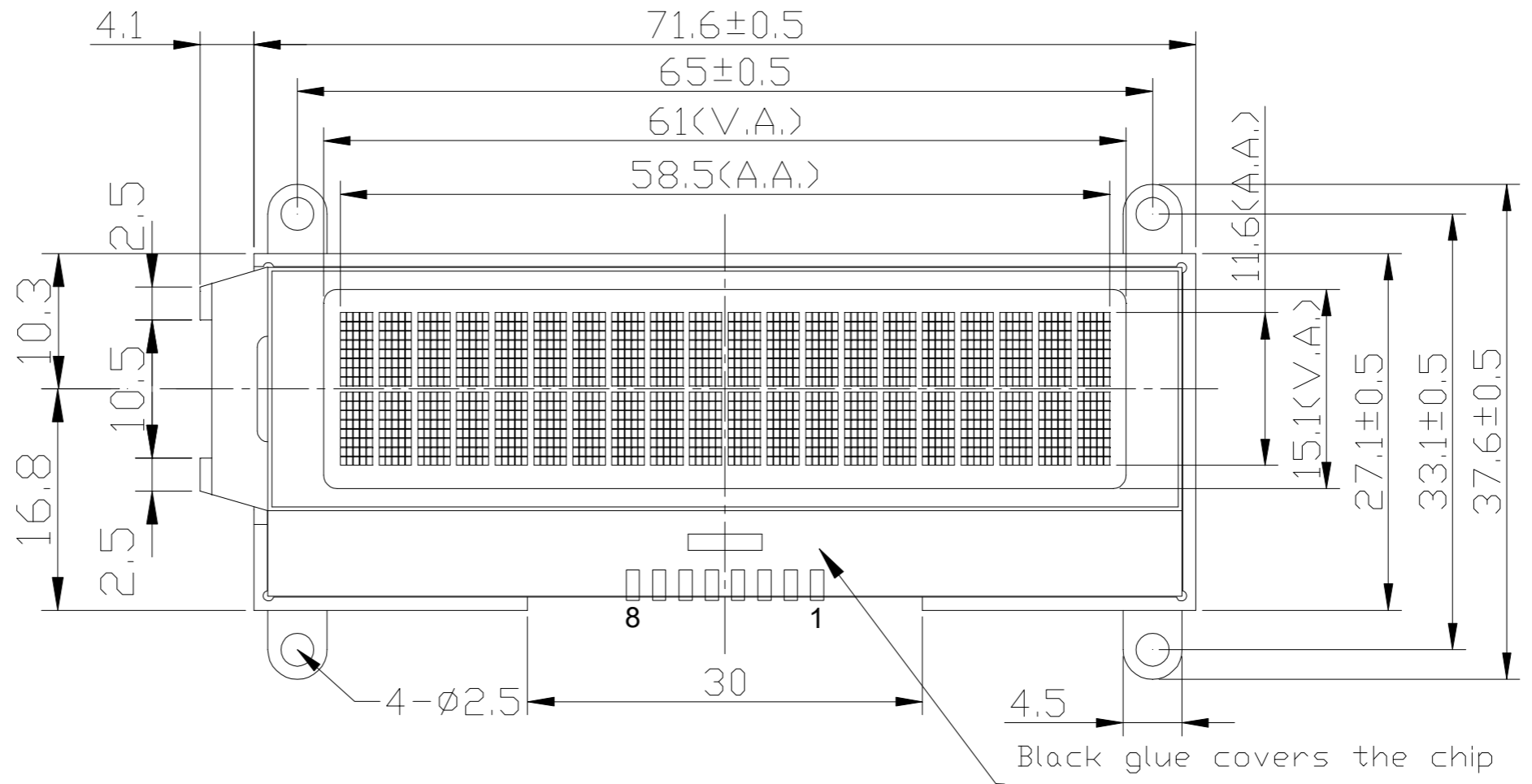
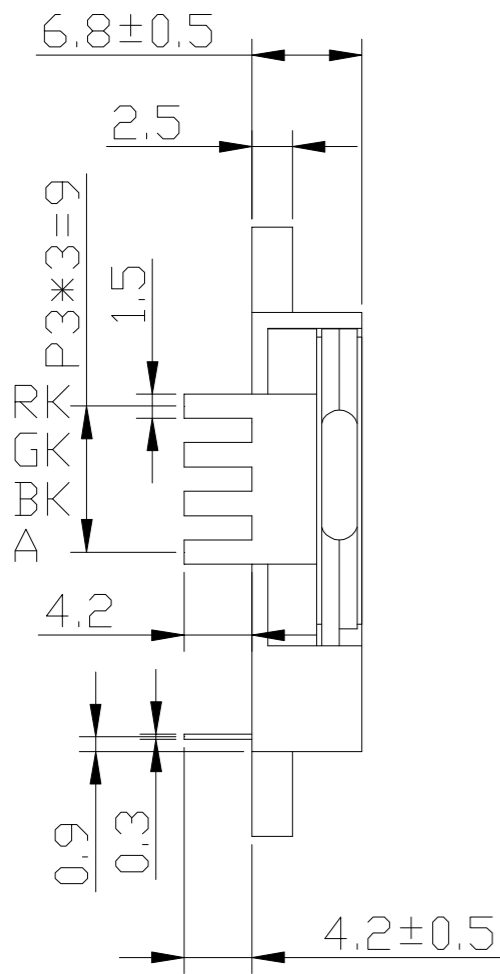

NO	SYMBOL
1	RST
2	SCL
3	SDA
4	VSS
5	VDD
6	VOUT
7	C1+
8	C1-

Product Description: 2x20 Character COG LCD

1. Driver IC: ST7036i
2. Driving Method: 1/16 Duty, 1/5 Bias
3. Interface: I²C
4. Power Requirement: 3.3V LCD
5. Optical Features: FSTN (+), Transflective, 6:00 View, RGB Backlight

Standard Tolerance: (Unless otherwise specified) Linear: $\pm 0.3\text{mm}$		
	Drawing/Part Number: NHD-C0220BiZ-FS(RGB)-FBW-3VM	Revision: 1.0
Unless otherwise specified: • Dimensions are in Millimeters • Third Angle Projection	Drawn By: K. Lewis Drawn Date: 02/13/2023	Approved By: K. Lewis Approved Date: 02/13/2023
	This drawing is solely the property of Newhaven Display International, Inc. The information it contains is not to be disclosed, reproduced or copied in whole or part without written approval from Newhaven Display.	

Mechanical Drawing

Recommended PCB Footprint

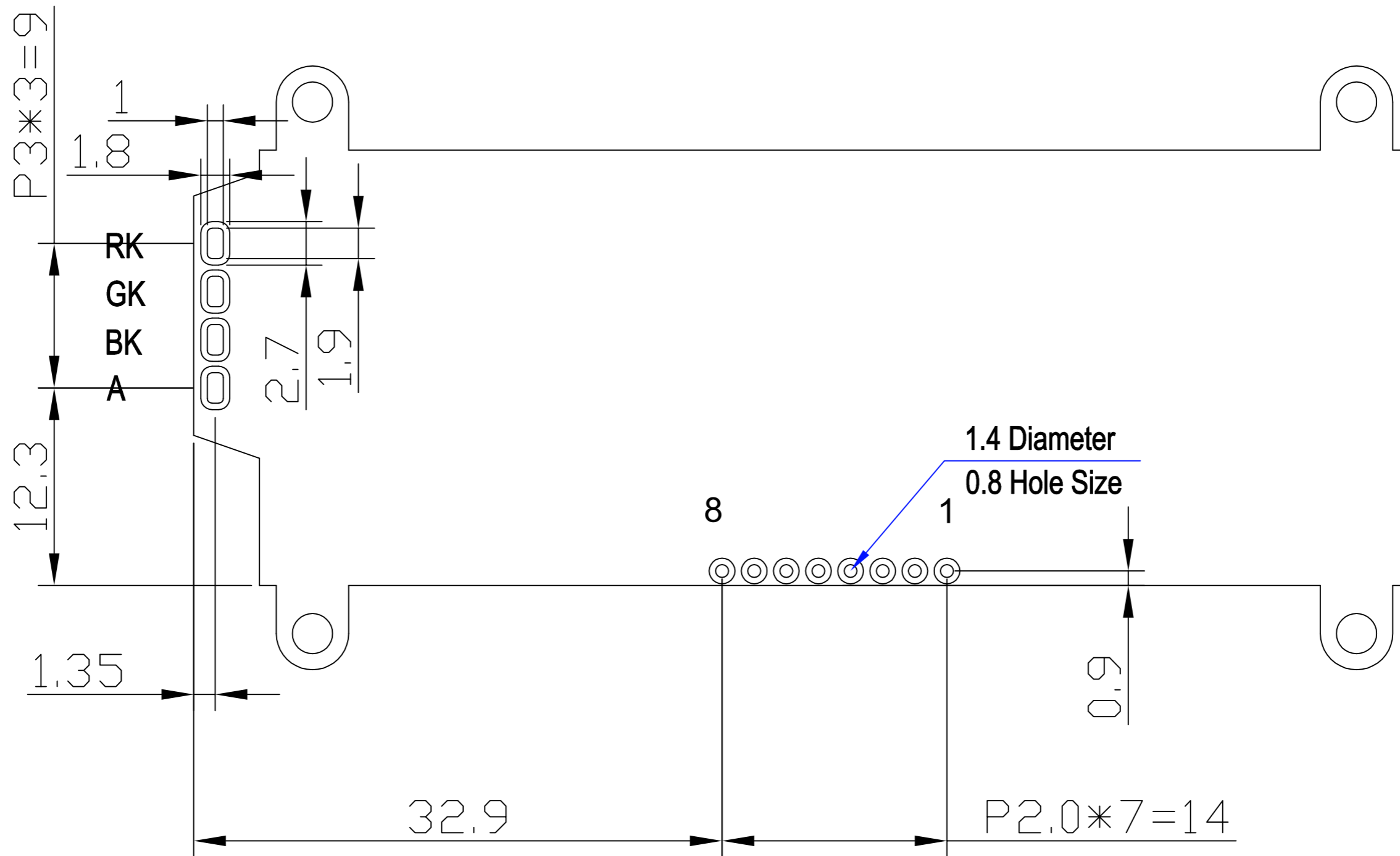

Applicable Displays:
 1. NHD-C0220BiZ-FS(RGB)-FBW-3VM

Standard Tolerance: (Unless otherwise specified) Linear: ±0.3mm		
	Drawing/Part Number: NHD-C0220BiZ-RGB-Footprint	Revision: 1.0
Unless otherwise specified: • Dimensions are in Millimeters • Third Angle Projection	Drawn By: K. Lewis	Approved By: K. Lewis
	Drawn Date: 02/10/2023	Approved Date: 02/10/2023
This drawing is solely the property of Newhaven Display International, Inc. The information it contains is not to be disclosed, reproduced or copied in whole or part without written approval from Newhaven Display.		

Pin Description

Pin No.	Symbol	External Connection	Function Description
1	RST	MPU	Active LOW Reset signal
2	SCL	MPU	Serial Clock signal (requires pull-up resistor)
3	SDA	MPU	Serial Data signal (requires pull-up resistor)
4	V _{SS}	Power Supply	Ground
5	V _{DD}	Power Supply	Supply Voltage for Logic (+3.3V)
6	V _{OUT}	CAP	Connect 1 μ F cap to V _{SS} or V _{DD}
7	C1+	CAP	Connect 0.47-2.2 μ F cap to PIN8
8	C1-	CAP	Connect 0.47-2.2 μ F cap to PIN7

Recommended LCD connector: N/A, solder directly into PCB

Backlight connector: 3.0mm pitch pins, solder directly into PCB **Mates with:** ---

Recommended Breakout Board: [NHD-PCB40](#)

Wiring Diagram

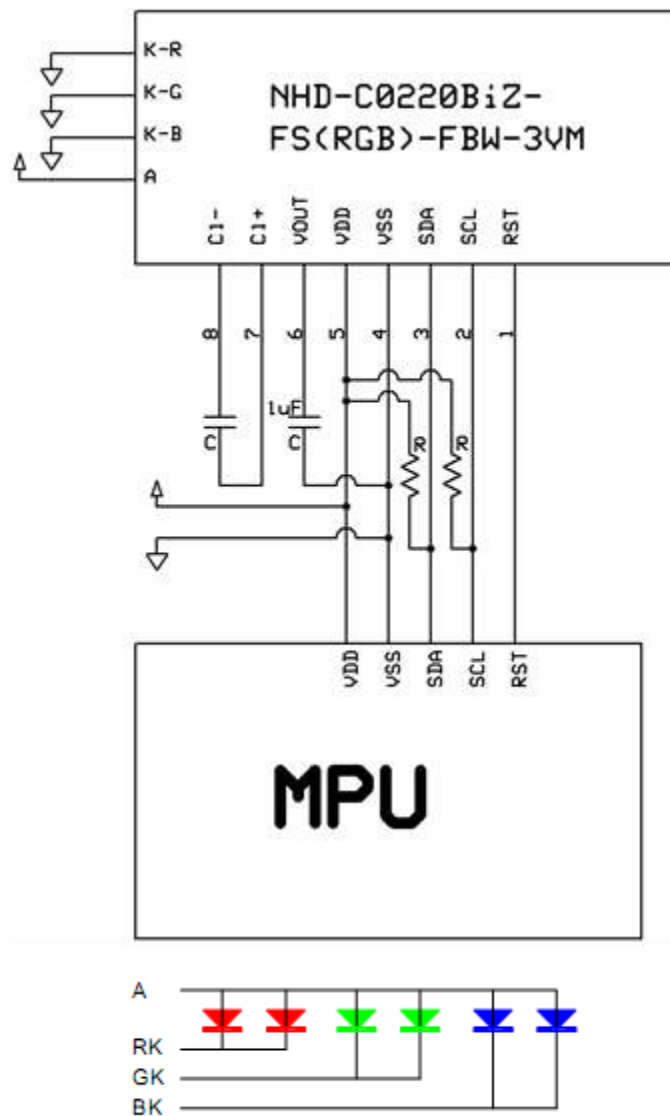

Capacitance 0.47 μ F~2.2 μ F; Recommended value = 1 μ F
 Recommended Resistor: 10k Ω

Electrical Characteristics

Item	Symbol	Condition	Min.	Typ.	Max.	Unit
Operating Temperature Range	T _{OP}	Absolute Max	-20	-	+70	°C
Storage Temperature Range	T _{ST}	Absolute Max	-30	-	+80	°C
Supply Voltage	V _{DD}	-	3.0	3.3	3.6	V
Supply Current	I _{DD}	V _{DD} = 3.3V	0.2	0.5	1.5	mA
Supply for LCD (contrast)	V _{LCD}	V ₀ -V _{SS} , T _{OP} = 25°C	5.3	5.5	5.7	V
"H" Level input	V _{IH}	-	0.7*VDD	-	VDD	V
"L" Level input	V _{IL}	-	VSS	-	0.8	V
"H" Level output	V _{OH}	-	0.7*VDD	-	VDD	V
"L" Level output	V _{OL}	-	VSS	-	0.8	V
Backlight Supply Voltage – RED	V _R	I _R = 20mA	1.7	1.9	2.1	V
Backlight Supply Current – RED	I _R	-	10	20	30	mA
Backlight Supply Voltage – GREEN	V _G	I _G = 30mA	2.7	2.9	3.1	V
Backlight Supply Current – GREEN	I _G	-	20	30	40	mA
Backlight Supply Voltage – BLUE	V _B	I _B = 30mA	2.7	2.9	3.1	V
Backlight Supply Current – BLUE	I _B	-	20	30	40	mA

*The LED of the backlight is driven by current; drive voltage is for reference only. Drive voltage must be selected to ensure backlight current drain is below MAX level stated.

Optical Characteristics

Item		Symbol	Condition	Min.	Typ.	Max.	Unit
Optimal Viewing Angles	Top	φY+	Cr ≥ 2	30	40	-	°
	Bottom	φY-		50	60	-	°
	Left	θX-		50	60	-	°
	Right	θX+		50	60	-	°
Contrast Ratio		Cr	-	2	5	-	-
Response Time	Rise	Tr	T _{OP} = 25°C	-	150	250	ms
	Fall	Tf		-	200	300	ms

Controller Information

Built-in ST7036i controller: <https://support.newhavendisplay.com/hc/en-us/articles/4414860535575-ST7036>

DDRAM Address

1	2	3	4	5	6	7	8	9	10	11	12	13	14	15	16	17	18	19	20
00	01	02	03	04	05	06	07	08	09	0A	0B	0C	0D	0E	0F	10	11	12	13
40	41	42	43	44	45	46	47	48	49	4A	4B	4C	4D	4E	4F	50	51	52	53



Slave Address = 0x78

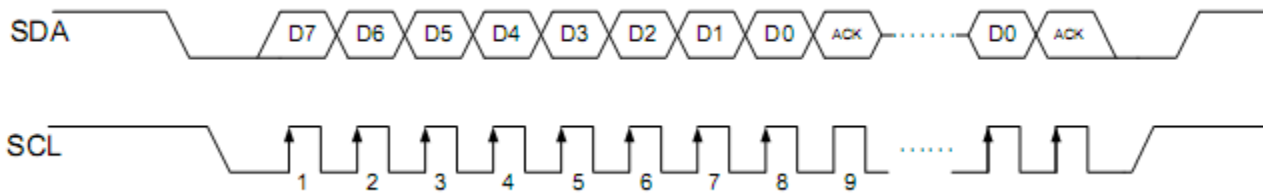
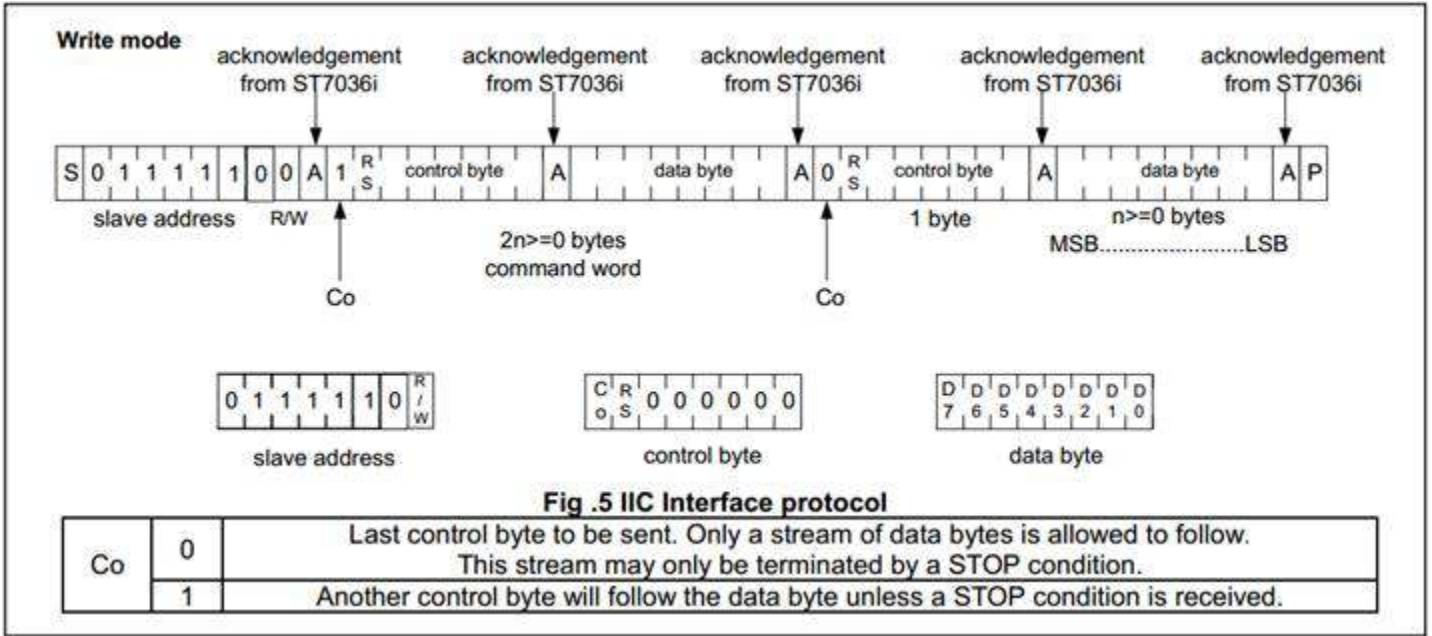

Table of Commands

Instruction	Instruction Code										Description	
	RS	R/W	DB7	DB6	DB5	DB4	DB3	DB2	DB1	DB0		
Clear Display	0	0	0	0	0	0	0	0	0	0	1	Write "20H" to DDRAM. and set DDRAM address to "00H" from AC
Return Home	0	0	0	0	0	0	0	0	0	1	x	Set DDRAM address to "00H" from AC and return cursor to its original position if shifted. The contents of DDRAM are not changed.
Entry Mode Set	0	0	0	0	0	0	0	0	1	I/D	S	Sets cursor move direction and specifies display shift. These operations are performed during data write and read.
Display ON/OFF	0	0	0	0	0	0	0	1	D	C	B	D=1:entire display on C=1:cursor on B=1:cursor position on
Function Set	0	0	0	0	1	DL	N	DH	IS2	IS1		DL: interface data is 8/4 bits N: number of line is 2/1 DH: double height font IS[2:1]: instruction table select
Set DDRAM Address	0	0	1	AC6	AC5	AC4	AC3	AC2	AC1	AC0		Set DDRAM address in address counter
Read Busy Flag and Address	0	1	BF	AC6	AC5	AC4	AC3	AC2	AC1	AC0		Whether during internal operation or not can be known by reading BF. The contents of address counter can also be read.
Write Data to RAM	1	0	D7	D6	D5	D4	D3	D2	D1	D0		Write data into internal RAM (DDRAM/CGRAM/ICONRAM)
Read Data from RAM	1	1	D7	D6	D5	D4	D3	D2	D1	D0		Read data from internal RAM (DDRAM/CGRAM/ICONRAM)

Instruction table 0(IS[2:1]=[0,0])											
Cursor or Display Shift	0	0	0	0	0	1	S/C	R/L	X	X	S/C and R/L: Set cursor moving and display shift control bit, and the direction, without changing DDRAM data.
Set CGRAM	0	0	0	1	AC5	AC4	AC3	AC2	AC1	AC0	Set CGRAM address in address counter

Instruction table 1(IS[2:1]=[0,1])											
Bias Set	0	0	0	0	0	1	BS	1	0	FX	BS=1:1/4 bias BS=0:1/5 bias FX: fixed on high in 3-line application and fixed on low in other applications.
Set ICON Address	0	0	0	1	0	0	AC3	AC2	AC1	AC0	Set ICON address in address counter.
Power/ICON Control/ Contrast Set	0	0	0	1	0	1	Ion	Bon	C5	C4	Ion: ICON display on/off Bon: set booster circuit on/off C5,C4: Contrast set for internal follower mode.
Follower Control	0	0	0	1	1	0	Fon	Rab ₂	Rab ₁	Rab ₀	Fon: set follower circuit on/off Rab2~0: select follower amplified ratio.
Contrast Set	0	0	0	1	1	1	C3	C2	C1	C0	Contrast set for internal follower mode.

Instruction table 2(IS[2:1]=[1,0])											
Double Height Position Select	0	0	0	0	0	1	UD	X	x	x	UD: Double height position select
Reserved	0	0	0	1	X	X	X	X	X	X	Do not use (reserved for test)

Timing Characteristics

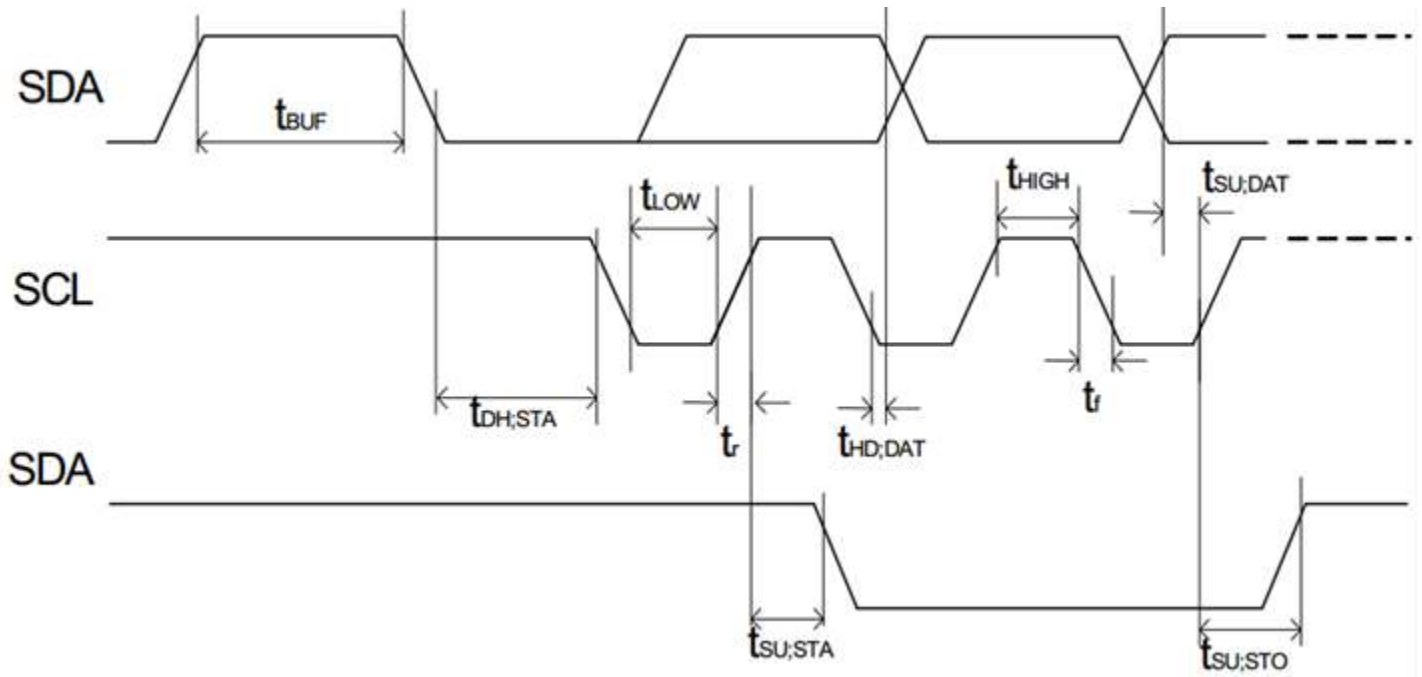

Item	Signal	Symbol	Condition	VDD=2.7 to 4.5V Rating		VDD=4.5 to 5.5V Rating		Units
				Min.	Max.	Min.	Max.	
SCL clock frequency		f_{SCLK}	—	DC	300K	DC	400	kHz
SCL clock low period	SCL	t_{LOW}	—	2.5	—	1.3	—	μ s
SCL clock high period		t_{HIGH}		0.6	—	0.6	—	
Data set-up time	SDA	$t_{SU,DAT}$	—	1800	—	700	—	ns
Data hold time		$t_{HD,DAT}$		0	—	0	0.5	
SCL,SDA rise time	SCL, SDA	t_r	—	$20+0.1C_b$	300	$20+0.1C_b$	300	ns
SCL,SDA fall time		t_f		$20+0.1C_b$	300	$20+0.1C_b$	300	
Capacitive load represent by each bus line		C_b	—	—	400	—	400	pf
Setup time for a repeated START condition	SDA	$t_{SU,STA}$	—	0.6	—	0.6	—	μ s
Start condition hold time		$t_{HD,STA}$		1.8	—	1.0	—	
Setup time for STOP condition		$t_{SU,STO}$	—	0.6	—	0.6	—	μ s
Bus free time between a Stop and START condition	SCL	t_{BUF}	—	1.3	—	1.3	—	μ s

Built-in Font Table (OPR1 = 0, OPR2 = 0)

b7-b6 b5-b0	0000	0001	0010	0011	0100	0101	0110	0111	1000	1001	1010	1011	1100	1101	1110	1111
0000																
0001																
0010																
0011																
0100																
0101																
0110																
0111																
1000																
1001																
1010																
1011																
1100																
1101																
1110																
1111																

Example Initialization Program

```

/*****
*           Initialization For ST7036i           *
*****/
void init_LCD()
{
I2C_Start();
I2C_out(Slave); //Slave=0x78
I2C_out(Comsend); //Comsend = 0x00
I2C_out(0x38);
delay(10);
I2C_out(0x39);
delay(10);
I2C_out(0x14);
I2C_out(0x78);
I2C_out(0x5E);
I2C_out(0x6D);
I2C_out(0x0C);
I2C_out(0x01);
I2C_out(0x06);
delay(10);
I2C_Stop();
}
/*****/

/*****
*           Output command or data via I2C           *
*****/
void I2C_out(unsigned char j)           //I2C Output
{
    int n;
    unsigned char d;
    d=j;
    for(n=0;n<8;n++){
        if((d&0x80)==0x80)
            SDA=1;
        else
            SDA=0;
        d=(d<<1);
        SCL = 0;
        SCL = 1;
        SCL = 0;
    }
    SCL = 1;
    while(SDA==1){
        SCL=0;
        SCL=1;
    }
    SCL=0;
}
/*****/

```

```

/*****
*           I2C Start                               *
*****/
void I2C_Start(void)
{
    SCL=1;
    SDA=1;
    SDA=0;
    SCL=0;
}
/*****/

/*****
*           I2C Stop                               *
*****/
void I2C_Stop(void)
{
    SDA=0;
    SCL=0;
    SCL=1;
    SDA=1;
}
/*****/

/*****
*           Send string of ASCII data to LCD       *
*****/
void Show(unsigned char *text)
{
    int n,d;
    d=0x00;
    I2C_Start();
    I2C_out(Slave); //Slave=0x78
    I2C_out(Datasend); //Datasend=0x40
    for(n=0;n<20;n++){
        I2C_out(*text);
        ++text;
    }
    I2C_Stop();
}
/*****/
/*****/
/*****/

```

Quality Information

Test Item	Content of Test	Test Condition	Note
High Temperature storage	Endurance test applying the high storage temperature for a long time.	+80°C , 48hrs	2
Low Temperature storage	Endurance test applying the low storage temperature for a long time.	-30°C , 48hrs	1,2
High Temperature Operation	Endurance test applying the electric stress (voltage & current) and the high thermal stress for a long time.	+70°C , 48hrs	2
Low Temperature Operation	Endurance test applying the electric stress (voltage & current) and the low thermal stress for a long time.	-20°C , 48hrs	1,2
High Temperature / Humidity Operation	Endurance test applying the electric stress (voltage & current) and the high thermal with high humidity stress for a long time.	40°C , 90% RH , 48hrs	1,2
Thermal Shock resistance	Endurance test applying the electric stress (voltage & current) during a cycle of low and high thermal stress.	0°C,30min -> 25°C,5min -> 50°C,30min = 1 cycle 10 cycles	
Vibration test	Endurance test applying vibration to simulate transportation and use.	10-55Hz , 15mm amplitude. 60 sec in each of 3 directions X,Y,Z For 15 minutes	3
Static electricity test	Endurance test applying electric static discharge.	VS=800V, RS=1.5kΩ, CS=100pF One time	

Note 1: No condensation to be observed.

Note 2: Conducted after 4 hours of storage at 25°C, 0%RH.

Note 3: Test performed on product itself, not inside a container.