

ATLANTIC VERSION TERMINATOR
 INTERFACE ADAPTER



PART NUMBER	REVISION	DESCRIPTION	FEED TYPE
2266119-1	K	FINE CRIMP HEIGHT ADJUST	MECHANICAL
2266119-2	K	FINE CRIMP HEIGHT ADJUST	PNEUMATIC
5-2266119-1	K	SEAL STRIPPER CRIMPER TERMINATING UNIT	MECHANICAL
5-2266119-2	K	SEAL STRIPPER CRIMPER TERMINATING UNIT	PNEUMATIC
7-2266119-1	K	MECHANICAL AND CRIMP TOOLING KIT	MECHANICAL
7-2266119-2	K	PNEUMATIC AND CRIMP TOOLING KIT	PNEUMATIC
7-2266119-7	L	CRIMP TOOLING KIT	-
7-2266119-8	C	APPLICATOR CONVERSION KIT	-

APPLICATOR DATA		
CRIMP	SIZE	TYPE
WIRE	1.75 mm [.069]	F
INSUL	1.73 mm [.068]	O

APPLICATOR INSTRUCTIONS
408-35042

APPLICATOR CONVERSION KITS	
PART NUMBER	INSULATION DIAMETER RANGE
7-2266116-8	∅2.74-3.18mm [.108-.125]
7-2266117-8	∅2.31-2.72mm [.091-.107]
7-2266118-8	∅1.91-2.29mm [.075-.090]
7-2266119-8	∅1.60-2.16mm [.063-.085]
7-2266120-8	∅1.27-1.57mm [.050-.062]

TERMINAL DATA: DEUTSCH TERMINAL DEUTSCH CRIMP SPECIFICATION			
TERMINAL NAME: STAMPED CONTACT PIN SIZE 20			
WIRE STRIP LENGTH	INSULATION DIAMETER RANGE	TE TERMINAL	DEUTSCH TERMINAL
3.81-5.09 mm [.150-.200 IN]	∅1.60-2.16 mm [.063-.085 IN]	1572032-3	1060-20-0222
3.81-5.09 mm [.150-.200 IN]	∅1.60-2.16 mm [.063-.085 IN]	1572032-4	1060-20-0244
3.81-5.09 mm [.150-.200 IN]	∅1.60-2.16 mm [.063-.085 IN]	1572032-8	1060-20-0277

TERMINAL DATA: DEUTSCH TERMINAL DEUTSCH CRIMP SPECIFICATION			
TERMINAL NAME: STAMPED CONTACT SOCKET SIZE 20			
WIRE STRIP LENGTH	INSULATION DIAMETER RANGE	TE TERMINAL	DEUTSCH TERMINAL
3.81-5.09 mm [.150-.200 IN]	∅1.60-2.16 mm [.063-.085 IN]	286680-3	1062-20-0222
3.81-5.09 mm [.150-.200 IN]	∅1.60-2.16 mm [.063-.085 IN]	286680-4	1062-20-0244
3.81-5.09 mm [.150-.200 IN]	∅1.60-2.16 mm [.063-.085 IN]	1-286680-1	1062-20-0277

WIRE SIZE	CRIMP HEIGHT mm [INCH]	CRIMP HEIGHT REFERENCE SETTING
1.50mm2	1.47+0.03/-0.05 [.058+.001/-0.002]	3.4
16 AWG	1.27+0.03/-0.05 [.050+.001/-0.002]	5.4
1.00mm2	1.27+0.03/-0.05 [.050+.001/-0.002]	5.4
18 AWG	1.24+0.03/-0.05 [.049+.001/-0.002]	5.7
0.75mm2	1.22+0.03/-0.05 [.048+.001/-0.002]	5.9
0.60mm2	1.07+0.03/-0.05 [.042+.001/-0.002]	7.4
20 AWG	0.99+0.03/-0.05 [.039+.001/-0.002]	8.2
0.50mm2	0.97+0.03/-0.05 [.038+.001/-0.002]	8.4
22 AWG	0.94+0.03/-0.05 [.037+.001/-0.002]	8.7
0.35mm2	0.94+0.03/-0.05 [.037+.001/-0.002]	8.7

- *WARNING**
 ON INSTALLATION, SET WIRE DISC TO CRIMP HEIGHT REFERENCE SETTING FOR LARGEST WIRE SIZE. CRIMP HEIGHT REFERENCE SETTINGS GREATER THAN THE VALUE SHOWN MAY CAUSE DAMAGE TO THE CRIMP TOOLING. REFER TO THE INSTRUCTION SHEET FOR PROPER SETUP AND ADJUSTMENTS.
- 1 RECOMMENDED SPARE PARTS
 - 2 REFER TO SUPPLIED INSTRUCTION SHEET FOR CLEANING, LUBRICATION AND STORAGE OF APPLICATOR.
 - 3 APPLY PART NUMBER 2-23419-6 LOCTITE TO THREADS OF ITEM 242. APPLY PART NUMBER 1-23419-5 LOCTITE TO THREADS OF ITEM 180.
 - 4 CRIMP HEIGHT REFERENCE SETTING WAS THE SETTING USED WHEN THE APPLICATOR WAS QUALIFIED AT THE FACTORY. ADJUSTMENT MAY BE NECESSARY WHEN RUNNING APPLICATOR IN THE FIELD.
 - 5 TERMINAL LUBRICANT IS RECOMMENDED.
 - 6. UNLESS SPECIFIED OTHERWISE TORQUE VALUES SHALL BE USED PER DOCUMENT, 101-35000.
 - 7 SEE APPROPRIATE APPLICATOR LOG SHEETS FOR APPLIED TERMINALS, WIRE RANGE AND MEMORY CHIP.

LOC	DIST	REV	LTN	DESCRIPTION	DATE	OWN	APPV
A	66	H	-	ECR-20-009609	06JUL2020	JWC	TE
		J	-	ECR-22-147794	28JUL2022	TB	GB
		K	-	ECR-22-149934	19AUG2022	FJ	JAH
		L	-	ECR-23-164045	17JAN2023	ROY	JAH

-	-	-	-	1	1	-	-	1803515-3	RAM ASSEMBLY, SF ATLANTIC	293
-	-	-	-	1	1	-	-	2-1803583-1	APPLICATOR BASIC ASSEMBLY, SF	292
-	-	2	2	2	2	2	2	2168083-1	SCR, SKT HD CAP, RoHS, M3 X 8.0	269
-	-	1	1	1	1	1	1	2-1633782-0	FENCE	267
-	-	1	-	1	-	1	-	2119641-1	FEED CAM, AIR FEED	248
-	-	1	1	1	1	1	1	2119082-9	CAM, SNAIL, INSULATION ADJUSTMENT	244
-	-	1	1	1	1	1	1	2079764-1	WASHER, WAVE SPRING, CREST-TO-CREST	243
-	-	1	1	1	1	1	1	2119083-1	RETAINER, INSULATION DIAL	242
-	-	1	1	1	1	1	1	7-18023-7	SCR, SKT HD CAP M3 X 4.0	241
-	-	-	-	1	-	1	-	2119580-1	MECHANICAL FEED ASSEMBLY	239
-	-	1	-	1	-	1	-	2844940-1	AIR FEED MODULE	238
-	-	-	-	1	1	-	-	4-1722335-3	STRIPPER, SIDE FEED	182
-	-	-	-	1	1	-	-	1-5018030-0	NUT, HEX, REG, RoHS, M3.5	181
-	-	-	-	1	1	-	-	1-1752354-8	STANDOFF,HOLD-DOWN	180
-	-	-	-	1	1	-	-	993111-1	PIN, SLOTTED SPRING 3.0 X 20.0	177
-	-	-	-	1	1	-	-	5-22280-0	SPRING, COMPRESSION	176
-	-	-	-	1	1	-	-	1752353-3	GUIDE PIN,HOLDDOWN	175
-	-	-	-	1	1	-	-	1901680-2	GUIDE PIN,HOLDDOWN	174
-	-	REF	REF	REF	REF	REF	REF	994970-2	COUNTER, MAGNETIC	164
-	-	1	1	1	1	1	1	1-18028-2	WASHER, FLAT, REG M4	119
-	-	1	1	1	1	1	1	2119955-1	ASSY, LUBRICATOR, SIDE FEED	113
-	-	1	1	1	1	1	1	2844908-1	SCREW, LOCKING	99
-	-	1	1	1	1	1	1	2844907-1	POST, LOCKING	98
-	-	1	1	1	1	1	1	455888-7	SPACER, CRIMPER	82
1	-	-	-	-	-	-	-	2266119	PRINT, APPLICATOR LOG SHEET	72
-	-	1	1	1	1	1	1	1803607-3	DOCUMENTATION PACKAGE	71
-	-	1	1	1	1	1	1	2119791-9	DEPRESSOR, WIRE	70
-	-	1	1	1	1	1	1	2119740-1	TAG, IDENTIFICATION	67
-	-	2	2	2	2	2	2	2168078-1	SCREW, DRIVE, RH, RoHS, 2 x .188	66
-	-	1	1	1	1	1	1	2168083-2	SCR, SKT HD CAP, RoHS, M4 X 8.0	60
-	-	1	1	1	1	1	1	5-18022-5	SCR, HEX HD CAP, M4 X 6.0	59
-	-	1	1	1	1	1	1	1338685-1	PAWL, FEED	56
-	-	4	4	4	4	4	4	2168083-3	SCR, SKT HD CAP, RoHS, M4 X 12.0	54
-	-	2	2	2	2	2	2	1-2168083-0	SCR, SKT HD CAP, RoHS, M4 X 10	53
-	-	1	1	1	1	1	1	1803382-6	HOLD DOWN, SPRING LOADED	50
-	-	1	2	1	2	1	2	18023-9	SCR, SKT HD CAP M4 X 6.0	49
-	-	-	-	1	-	1	-	2119652-1	FEED CAM, PRE FEED	48
-	-	-	-	1	-	1	-	2119653-1	FEED CAM, POST FEED	47
-	-	1	1	-	-	1	1	1803583-9	APPLICATOR BASIC ASSEMBLY, SF	46
-	-	1	1	-	-	1	1	1803515-1	RAM ASSEMBLY, SF ATLANTIC	44
-	-	1	1	1	1	1	1	1803602-1	SCR, BHSC, RoHS (M8 X 25)	41
-	-	1	1	1	1	1	1	2-1752356-0	SUPPORT, TERMINAL	34
-	-	2	2	2	2	2	2	2079383-5	SCR, BHSC, RoHS (M4 X 20)	33
-	-	2	2	2	2	2	2	2-2844962-8	SPACER, CYLINDRICAL, STRIP GUIDE	30
-	-	1	1	1	1	1	1	2844992-1	ASSEMBLY, STRIP GUIDE	29
-	-	1	1	1	1	1	1	1320928-2	STRIP GUIDE	24
-	-	1	1	-	-	1	1	2168083-2	SCR, SKT HD CAP, RoHS, M4 X 8.0	21
-	-	2	2	1	1	2	2	1-18028-2	WASHER, FLAT, REG M4	20
-	-	1	1	-	-	1	1	2119533-1	STRIPPER, SIDE FEED	19
-	-	1	1	1	1	1	1	2119806-1	INSERT, SHEAR	13
-	-	1	1	1	1	1	1	3-22280-3	SPRING, COMPRESSION	12
-	-	1	1	1	1	1	1	1-356885-4	STOP, SHEAR	11
-	-	1	1	1	1	1	1	2119805-1	SHEAR HOLDER, FRONT	10
-	-	1	1	1	1	1	1	1803095-1	FLOATING SHEAR, FRONT	9
1	1	2	2	1	1	1	1	1-1803293-5	ANVIL, COMBINATION DEUTSCH STYLE	8
-	-	1	1	1	1	1	1	2-240641-8	SPACER	7
-	-	-	-	-	-	-	-	-	-	6
-	-	1	1	1	1	1	1	1-2119757-2	DEPRESSOR, SHEAR	5
-	-	1	1	1	1	1	1	238011-9	BLOCK, CRIMPER SPACER	4
1	1	2	2	1	1	1	1	1803019-7	CRIMPER, INSULATION O	3
-	-	1	1	1	1	1	1	455888-7	SPACER, CRIMPER	2
-	-	1	2	2	1	1	1	1803364-2	CRIMPER, WIRE PREMIUM	1

ATLANTIC VERSION
 Shown on sheets 1 of 4 & 2 of 4
 (Pacific version shown on sheets 3 of 4 & 4 of 4)

DIMENSIONS: mm		TOLERANCES UNLESS OTHERWISE SPECIFIED:		DRAWN R. KNEPPER 16-Oct-13		CHK G. BAILEY 16-Oct-13		APPROVED M. CLIFFORD 16-Oct-13		NAME Ocean Side Feed Applicator	
0 PLC	±	1 PLC	±	2 PLC	±	3 PLC	±	4 PLC	±	ANGLES	±
MATERIAL		FINISH		WEIGHT		SIZE		CAGE CODE		DRAWING NO	
						A1		00779		C=2266119	
Customer Accessible Production Drawing				SCALE		SHEET		1 OF 4		REV	
				1:2						L	

LOC	DIST	REVISIONS					
A	66	P	LYN	DESCRIPTION	DATE	DWN	APVD
		-		SEE SHEET 1			

FEED TYPE MECHANICAL

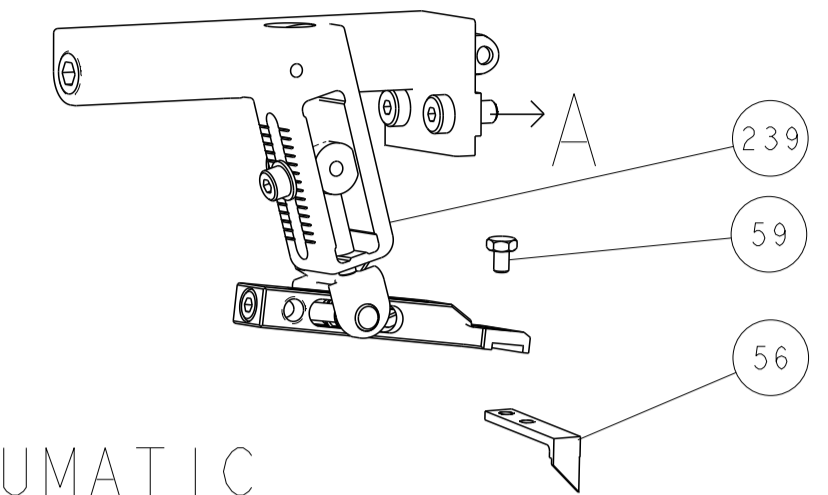

PNEUMATIC

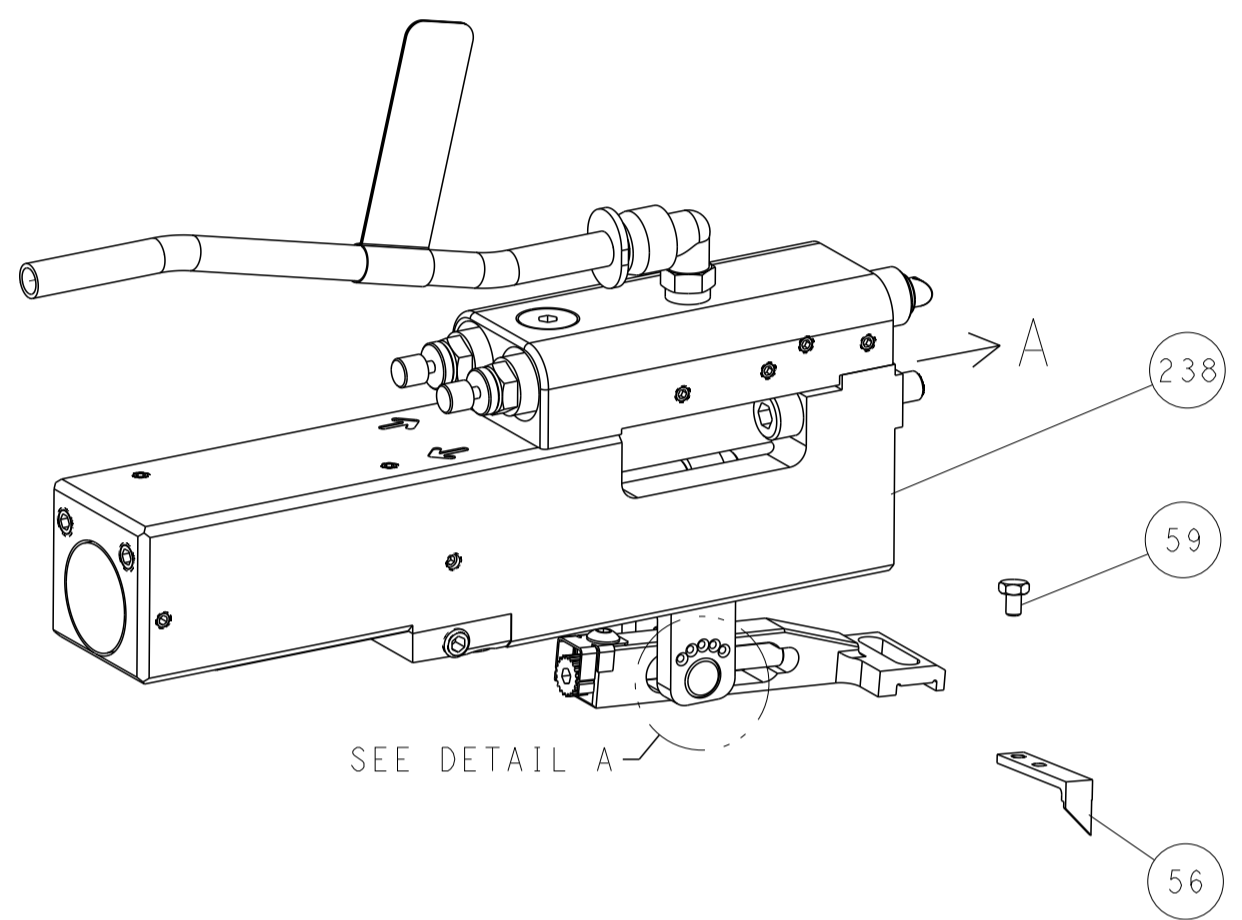

FEED SPRING SETTING POSITION (SHOWN FROM REAR SIDE)



DETAIL A

CAM POSITIONS

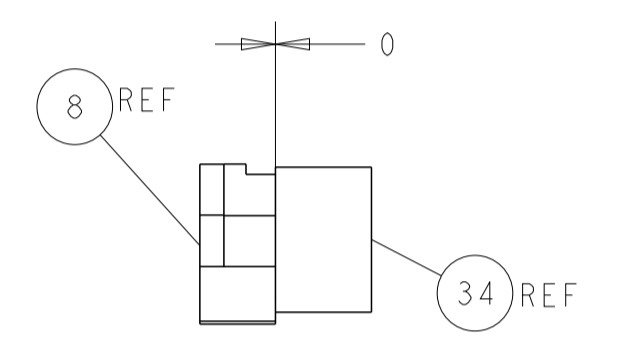
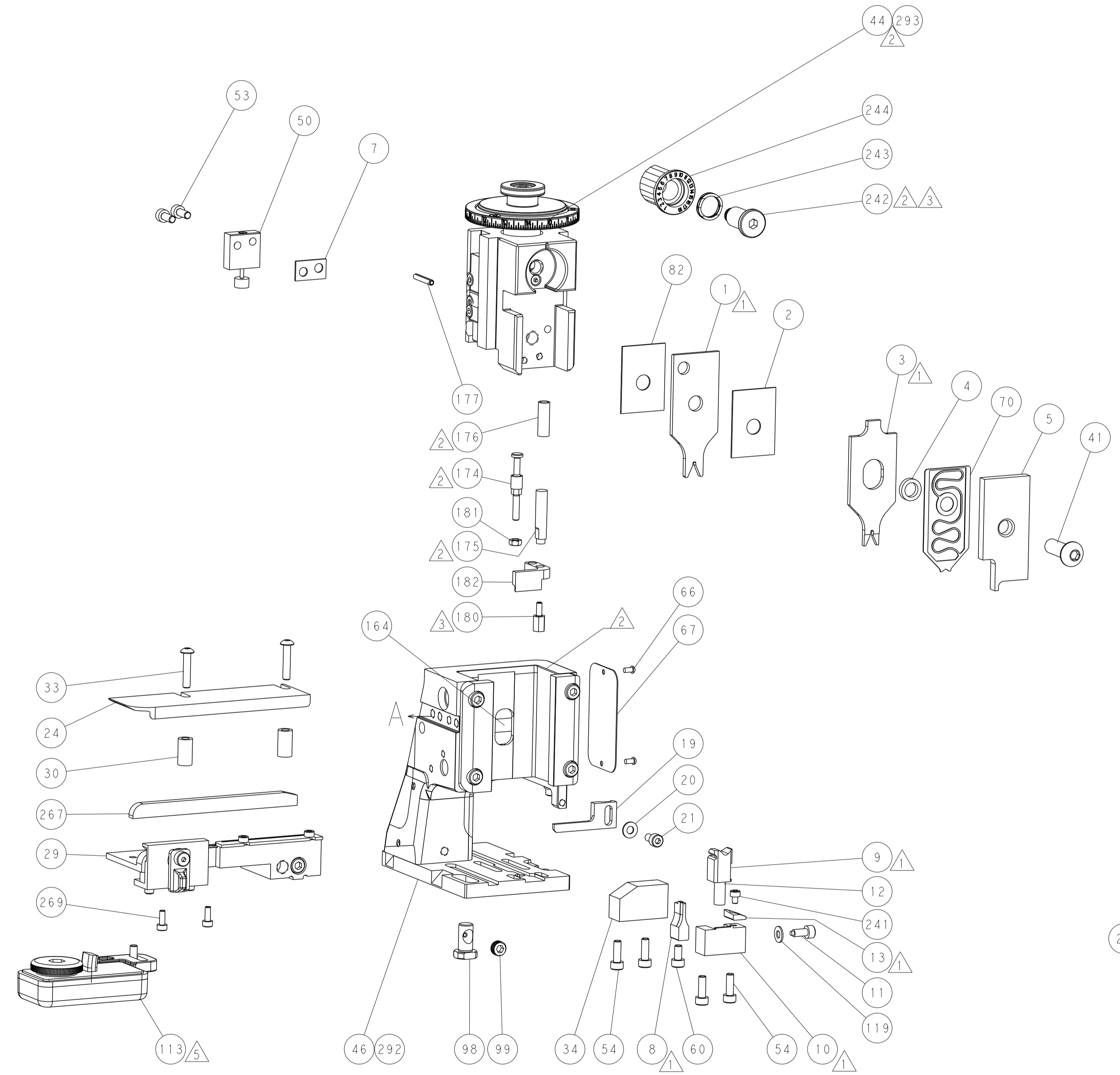
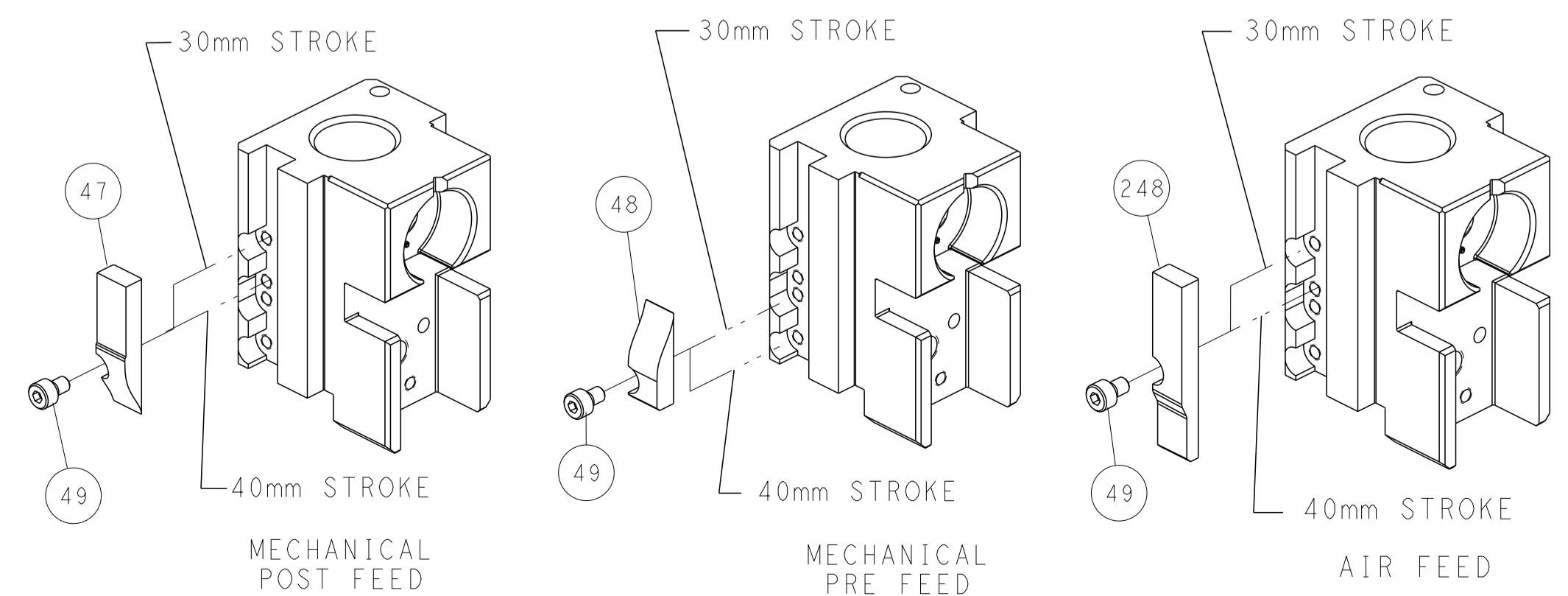

TERMINAL SUPPORT LOCATION

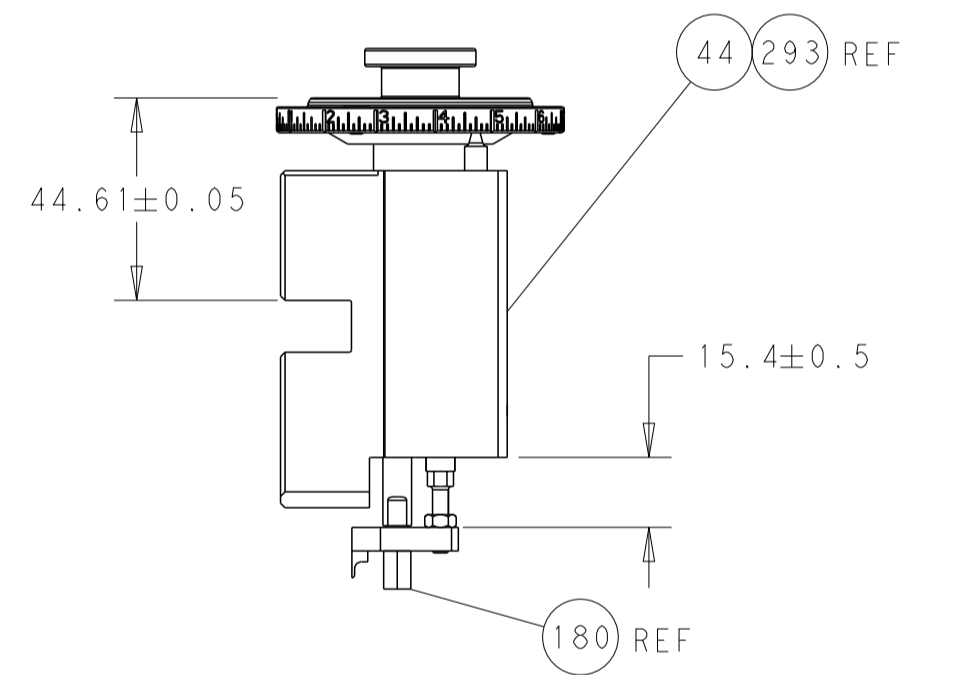

RAM SET-UP

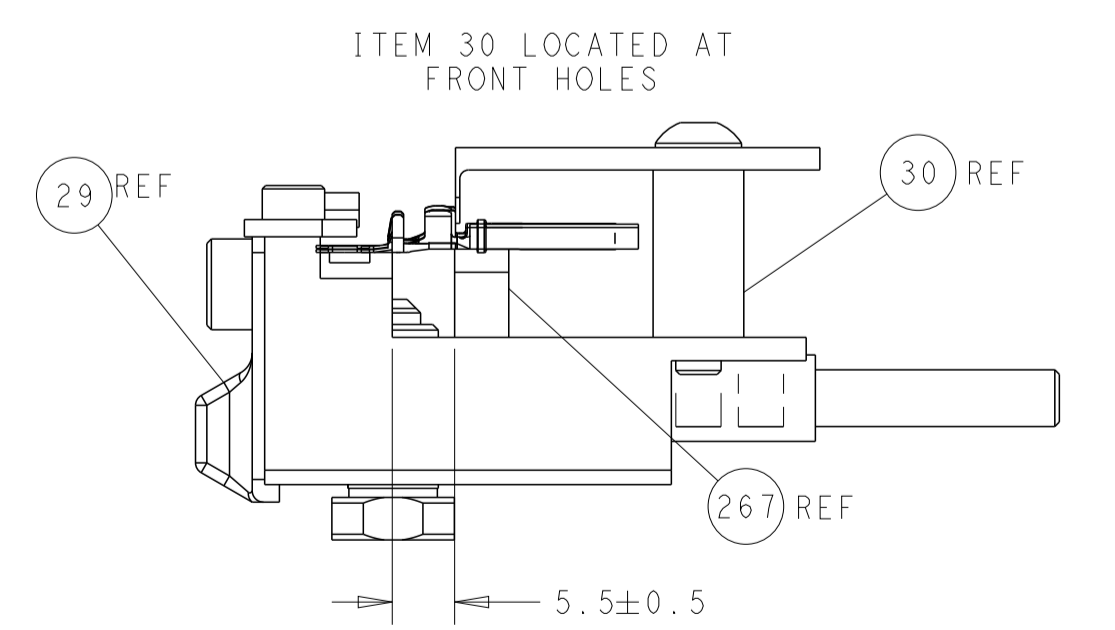

FEED TRACK POSITION GUIDE BY WIRE BARREL

ATLANTIC VERSION
 Shown on sheets 1 of 4 & 2 of 4
 (Pacific version shown on sheets 3 of 4 & 4 of 4)

<small>THIS DRAWING IS UNPUBLISHED. RELEASED FOR PUBLICATION. ALL RIGHTS RESERVED. THIS IS THE PROPERTY OF TYCO ELECTRONICS CORPORATION. IT IS TO BE USED ONLY FOR THE PURPOSES AND IN THE QUANTITIES SPECIFIED IN THE ORDER. NO PARTS OF THIS DRAWING ARE TO BE REPRODUCED OR TRANSMITTED IN ANY FORM OR BY ANY MEANS, ELECTRONIC OR MECHANICAL, INCLUDING PHOTOCOPYING, RECORDING, OR BY ANY INFORMATION STORAGE AND RETRIEVAL SYSTEM, WITHOUT THE WRITTEN PERMISSION OF TYCO ELECTRONICS CORPORATION.</small>		DWN: R. KNEPPER 16-Oct-13 CHK: G. BAILEY 16-Oct-13 APVD: M. CLIFFORD 16-Oct-13	NAME: TE Connectivity Harrisburg, PA 17105-3608
DIMENSIONS: mm TOLERANCES UNLESS OTHERWISE SPECIFIED: 0 PLC ± 1 PLC ± 2 PLC ± 3 PLC ± 4 PLC ± ANGLES FINISH	MATERIAL:	PRODUCT SPEC: APPLICATION SPEC: WEIGHT:	SIZE: A1 CAGE CODE: 00779 DRAWING NO: C=2266119 SCALE: 1:2 SHEET: 2 of 4 REV: L

PART NUMBER	REVISION	DESCRIPTION	FEED TYPE
2-2266119-1	K	FINE CRIMP HEIGHT ADJUST	MECHANICAL
2-2266119-2	K	FINE CRIMP HEIGHT ADJUST	PNEUMATIC
7-2266119-7	L	CRIMP TOOLING KIT	-
7-2266119-8	C	APPLICATOR CONVERSION KIT	-

PACIFIC VERSION TERMINATOR
INTERFACE ADAPTER



APPLICATOR DATA		
CRIMP	SIZE	TYPE
WIRE	1.75 mm [.069]	F
INSUL	1.73 mm [.068]	O
APPLICATOR INSTRUCTIONS 408-35042		

APPLICATOR CONVERSION KITS	
PART NUMBER	INSULATION DIAMETER RANGE
7-2266116-8	Ø 2.74-3.18mm [.108-.125]
7-2266117-8	Ø 2.31-2.72mm [.091-.107]
7-2266118-8	Ø 1.91-2.29mm [.075-.090]
7-2266119-8	Ø 1.60-2.16mm [.063-.085]
7-2266120-8	Ø 1.27-1.57mm [.050-.062]

TERMINAL DATA: DEUTSCH TERMINAL DEUTSCH CRIMP SPECIFICATION			
TERMINAL NAME: STAMPED CONTACT PIN SIZE 20			
WIRE STRIP LENGTH	INSULATION DIAMETER RANGE		
3.81-5.09 mm [1.50-.200 IN]	Ø 1.60-2.16 mm [.063-.085 IN]		
TERMINAL APPLICATION SPECIFICATION	114-151003 Rev A1	-	-
TERMINALS APPLIED			
TE TERMINAL	DEUTSCH TERMINAL	TE TERMINAL	DEUTSCH TERMINAL
1572032-3	1060-20-0222	1572032-4	1060-20-0244
1572032-8	1060-20-0277		

TERMINAL DATA: DEUTSCH TERMINAL DEUTSCH CRIMP SPECIFICATION			
TERMINAL NAME: STAMPED CONTACT SOCKET SIZE 20			
WIRE STRIP LENGTH	INSULATION DIAMETER RANGE		
3.81-5.09 mm [1.50-.200 IN]	Ø 1.60-2.16 mm [.063-.085 IN]		
TERMINAL APPLICATION SPECIFICATION	114-151003 Rev A1	-	-
TERMINALS APPLIED			
TE TERMINAL	DEUTSCH TERMINAL	TE TERMINAL	DEUTSCH TERMINAL
286680-3	1062-20-0222	286680-4	1062-20-0244
1-286680-1	1062-20-0277		

WIRE SIZE	CRIMP HEIGHT mm [INCH]	CRIMP HEIGHT REFERENCE SETTING
1.50mm2	1.47+0.03/-0.05 [.058+.001/-0.002]	3.4
16 AWG	1.27+0.03/-0.05 [.050+.001/-0.002]	5.4
1.00mm2	1.27+0.03/-0.05 [.050+.001/-0.002]	5.4
18 AWG	1.24+0.03/-0.05 [.049+.001/-0.002]	5.7
0.75mm2	1.22+0.03/-0.05 [.048+.001/-0.002]	5.9
0.60mm2	1.07+0.03/-0.05 [.042+.001/-0.002]	7.4
20 AWG	0.99+0.03/-0.05 [.039+.001/-0.002]	8.2
0.50mm2	0.97+0.03/-0.05 [.038+.001/-0.002]	8.4
22 AWG	0.94+0.03/-0.05 [.037+.001/-0.002]	8.7
0.35mm2	0.94+0.03/-0.05 [.037+.001/-0.002]	8.7

- 1 RECOMMENDED SPARE PARTS
- 2 REFER TO SUPPLIED INSTRUCTION SHEET FOR CLEANING, LUBRICATION AND STORAGE OF APPLICATOR.
- 3 APPLY PART NUMBER 2-23419-6 LOCTITE TO THREADS OF ITEM 242.
- 4 CRIMP HEIGHT REFERENCE SETTING WAS THE SETTING USED WHEN THE APPLICATOR WAS QUALIFIED AT THE FACTORY. ADJUSTMENT MAY BE NECESSARY WHEN RUNNING APPLICATOR IN THE FIELD.
- 5 TERMINAL LUBRICANT IS RECOMMENDED.
- 6. UNLESS SPECIFIED OTHERWISE TORQUE VALUES SHALL BE USED PER DOCUMENT, 101-35000.
- 7 SEE APPROPRIATE APPLICATOR LOG SHEETS FOR APPLIED TERMINALS, WIRE RANGE AND MEMORY CHIP.

***WARNING**
ON INSTALLATION, SET WIRE DISC TO CRIMP HEIGHT REFERENCE SETTING FOR LARGEST WIRE SIZE. CRIMP HEIGHT REFERENCE SETTINGS GREATER THAN THE VALUE SHOWN MAY CAUSE DAMAGE TO THE CRIMP TOOLING. REFER TO THE INSTRUCTION SHEET FOR PROPER SETUP AND ADJUSTMENTS.

PACIFIC VERSION
Shown on sheets 3 of 4 & 4 of 4
(Atlantic version shown on sheets 1 of 4 & 2 of 4)

LOC	DIST	REVISIONS					
A	66	P	LTN	DESCRIPTION	DATE	OWN	APVD
-	-	-	-	SEE SHEET 1	-	-	-

-	-	2	2	2168083-1	SCR, SKT HD CAP, RoHS, M3 X 8.0	269
-	-	1	1	2-1633782-0	FENCE	267
-	-	1	1	2119082-9	CAM, SNAIL, INSULATION ADJUSTMENT	244
-	-	1	1	2079764-1	WASHER, WAVE SPRING, CREST-TO-CREST	243
3	-	1	1	2119083-1	RETAINER, INSULATION DIAL	242
-	-	1	1	7-18023-7	SCR, SKT HD CAP M3 X 4.0	241
-	-	-	1	2119580-1	MECHANICAL FEED ASSEMBLY	239
-	-	1	-	2844940-1	AIR FEED MODULE	238
-	-	REF	REF	994970-2	COUNTER, MAGNETIC	164
-	-	1	-	2119641-2	FEED CAM, AIR FEED	151
-	-	1	1	2168083-8	SCR, SKT HD CAP, RoHS, M4 X 16	144
-	-	4	4	2168083-9	SCR, SKT HD CAP, RoHS, M4 X 20	143
-	-	-	1	2119653-2	FEED CAM, POST FEED	142
-	-	1	1	1-1803583-0	APPLICATOR BASIC ASSEMBLY, SF	141
-	-	1	1	1803516-1	RAM ASSEMBLY, SF PACIFIC	140
-	-	1	1	1-18028-2	WASHER, FLAT, REG M4	119
5	-	1	1	2119955-1	ASSY, LUBRICATOR, SIDE FEED	113
-	-	1	1	2844908-1	SCREW, LOCKING	99
-	-	1	1	2844907-1	POST, LOCKING	98
-	-	1	1	455888-7	SPACER, CRIMPER	82
1	-	-	-	2266119	PRINT, APPLICATOR LOG SHEET	72
-	-	1	1	1803607-3	DOCUMENTATION PACKAGE	71
-	-	1	1	2119791-9	DEPRESSOR, WIRE	70
-	-	1	1	2119740-1	TAG IDENTIFICATION	67
-	-	2	2	2168078-1	SCREW, DRIVE, RH, RoHS, 2 x .188	66
-	-	1	1	5-18022-5	SCR, HEX HD CAP, M4 X 6.0	59
-	-	1	1	1338685-1	PAWL, FEED	56
-	-	2	2	1-2168083-0	SCR, SKT HD CAP, RoHS, M4 X 10	53
-	-	1	1	1803382-6	HOLD DOWN, SPRING LOADED	50
-	-	1	2	18023-9	SCR, SKT HD CAP M4 X 6.0	49
-	-	-	1	2119652-1	FEED CAM, PRE FEED	48
-	-	1	1	1803602-1	SCR, BHSC, RoHS (M8 X 25)	41
-	-	1	1	2-1752356-0	SUPPORT, TERMINAL	34
-	-	2	2	2079383-5	SCR, BHSC, RoHS (M4 X 20)	33
-	-	2	2	2-2844962-8	SPACER, CYLINDRICAL, STRIP GUIDE	30
-	-	1	1	2844992-1	ASSEMBLY, STRIP GUIDE	29
-	-	1	1	1320928-2	STRIP GUIDE	24
-	-	1	1	2168083-2	SCR, SKT HD CAP, RoHS, M4 X 8.0	21
-	-	1	1	1-18028-2	WASHER, FLAT, REG M4	20
-	-	1	1	2119533-1	STRIPPER, SIDE FEED	19
1	-	1	1	2119806-1	INSERT, SHEAR	13
-	-	1	1	3-22280-3	SPRING, COMPRESSION	12
-	-	1	1	1-356885-4	STOP, SHEAR	11
1	-	1	1	2119805-1	SHEAR HOLDER, FRONT	10
1	-	1	1	1803095-1	FLOATING SHEAR, FRONT	9
1	1	1	1	1-1803293-5	ANVIL, COMBINATION DEUTSCH STYLE	8
-	-	1	1	2-240641-8	SPACER	7
-	-	-	-	-	-	6
-	-	1	1	1-2119757-2	DEPRESSOR, SHEAR	5
-	-	1	1	238011-9	BLOCK, CRIMPER SPACER	4
1	1	1	1	1803019-7	CRIMPER, INSULATION O	3
-	-	1	1	455888-7	SPACER, CRIMPER	2
1	-	1	1	1803364-2	CRIMPER, WIRE PREMIUM	1
-	-	78	77	22	21	

DIMENSIONS:		TOLERANCES UNLESS OTHERWISE SPECIFIED:		MATERIAL:		FINISH:		WEIGHT:		SCALE:		SHEET:		REV:	
mm	0 PLC ±	1 PLC ±	2 PLC ±	3 PLC ±	4 PLC ±	ANGLES	FINISH			Customer Accessible Production Drawing	1:2	3	4	L	

CHK	DATE	NAME	DESCRIPTION	ITEM NO
R. KNEPPER	16-Oct-13		TE Connectivity	
G. BAILEY	16-Oct-13		Harrisburg, PA 17105-3608	
M. CLIFFORD	16-Oct-13			
Ocean Side Feed Applicator				
SIZE: 00779 C=2266119				

LOC	DIST	REVISIONS					
A	66	P	LTN	DESCRIPTION	DATE	DMN	APVD
		-		SEE SHEET 1			

FEED TYPE MECHANICAL

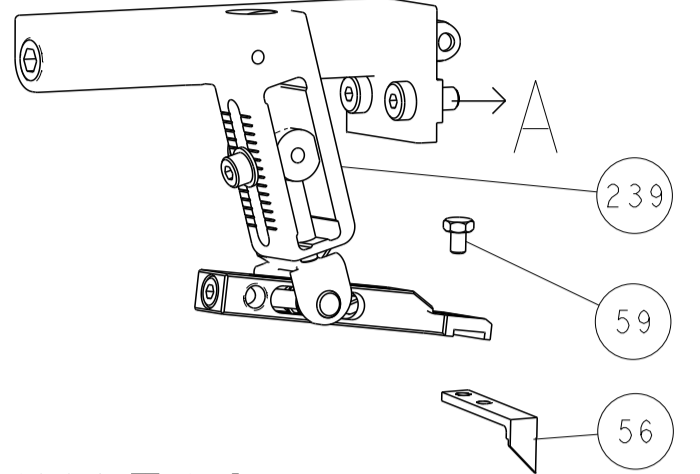

PNEUMATIC

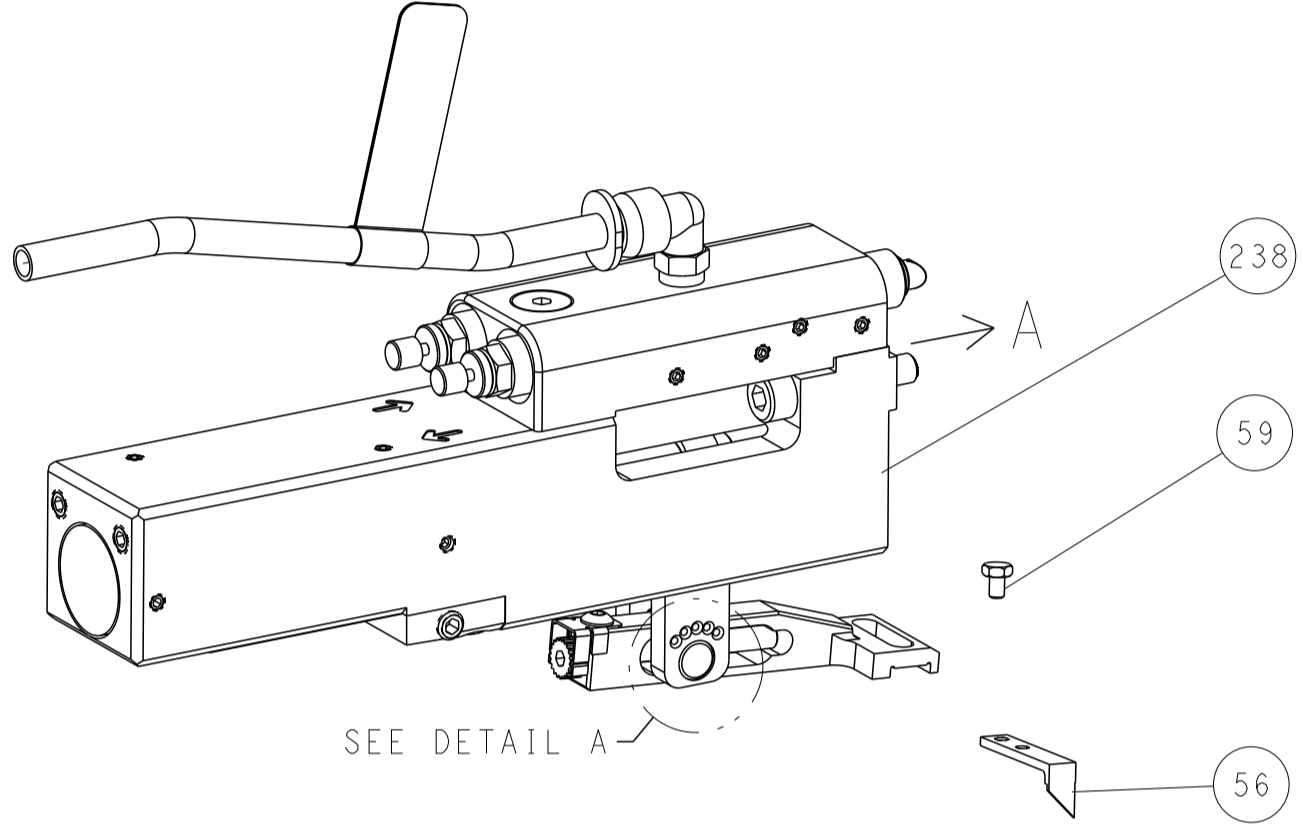

FEED SPRING SETTING POSITION (SHOWN FROM REAR SIDE)

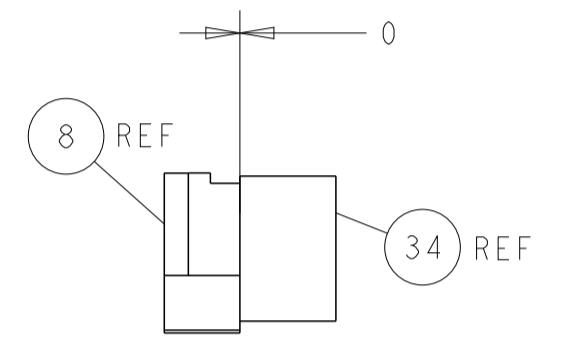
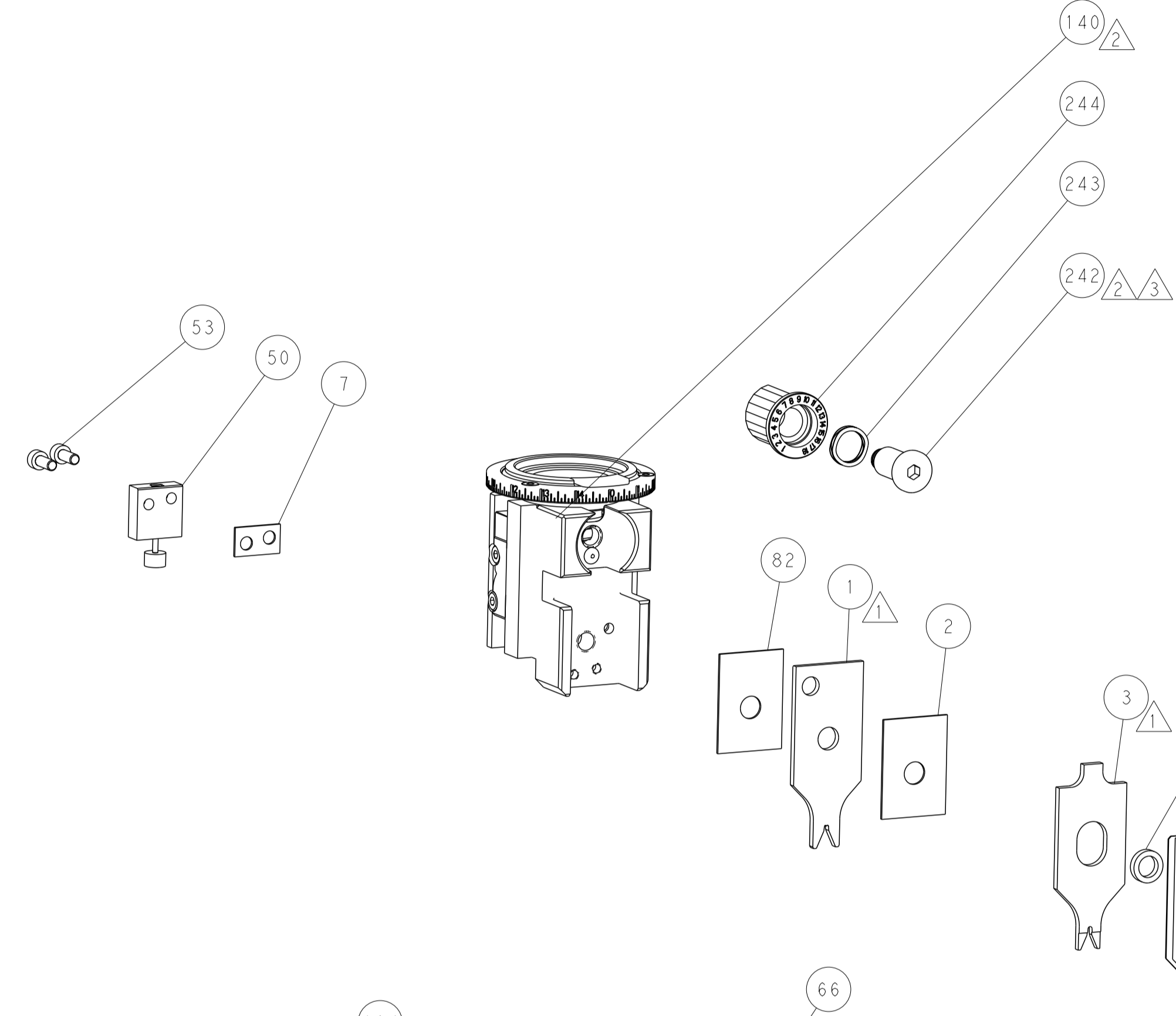

TERMINAL SUPPORT LOCATION

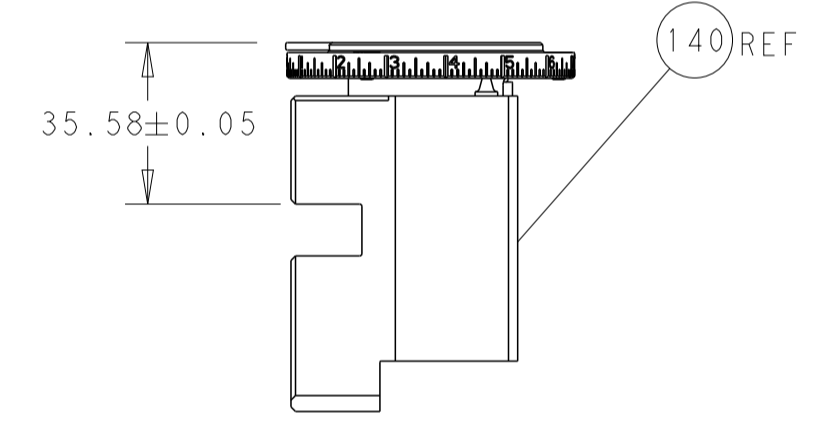

RAM SET-UP

FEED SPRING SETTING POSITION (SHOWN FROM REAR SIDE)

DETAIL A

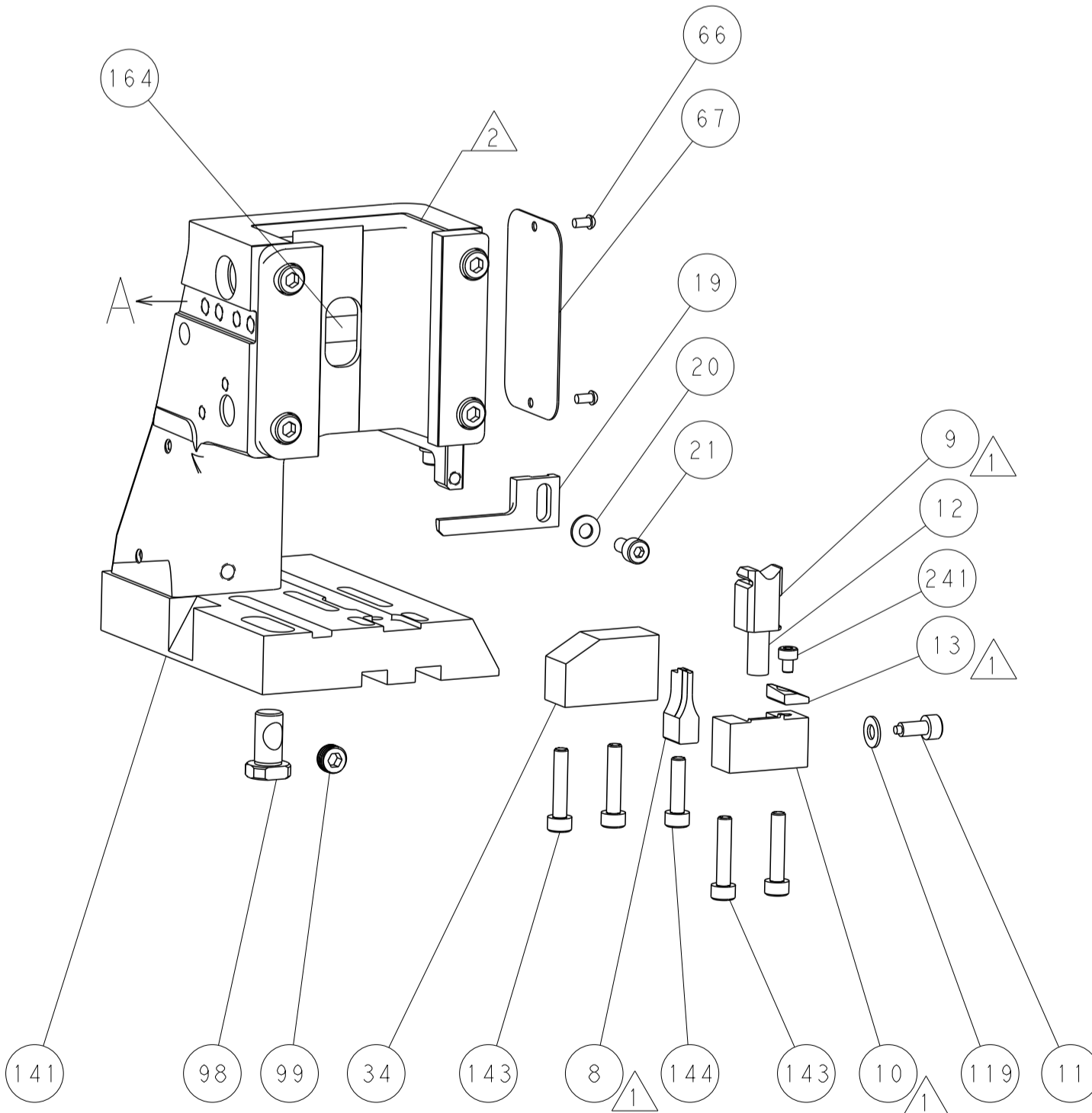
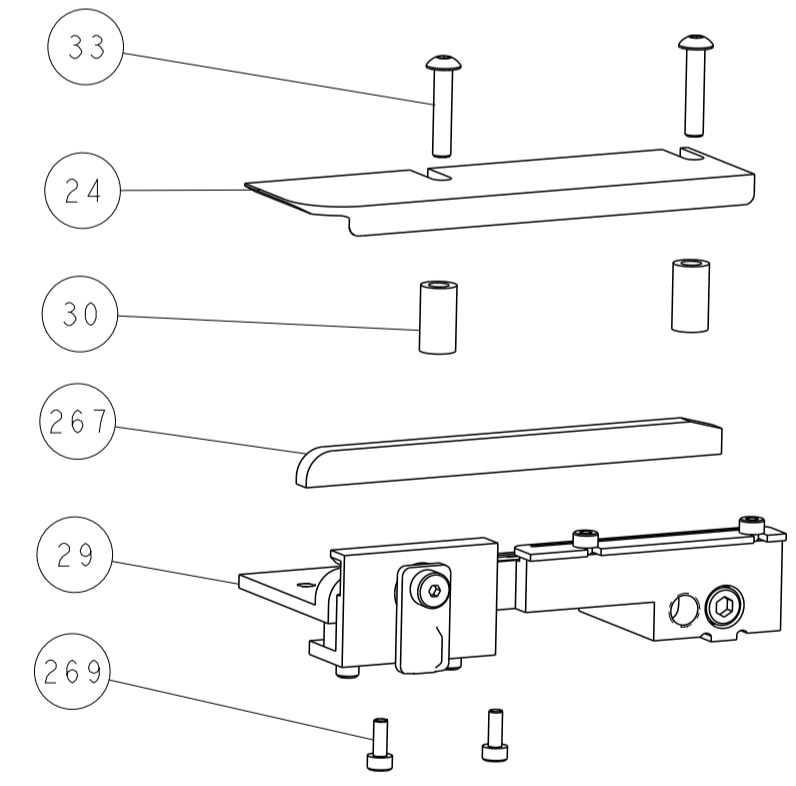

ITEM 30 LOCATED AT FRONT HOLES

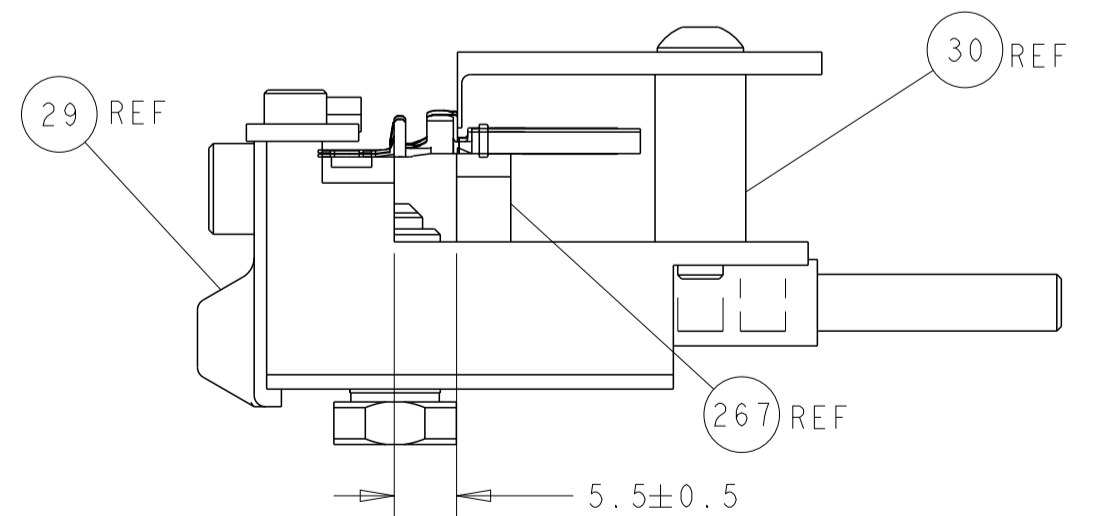

FEED TRACK POSITION GUIDE BY WIRE BARREL

CAM POSITIONS

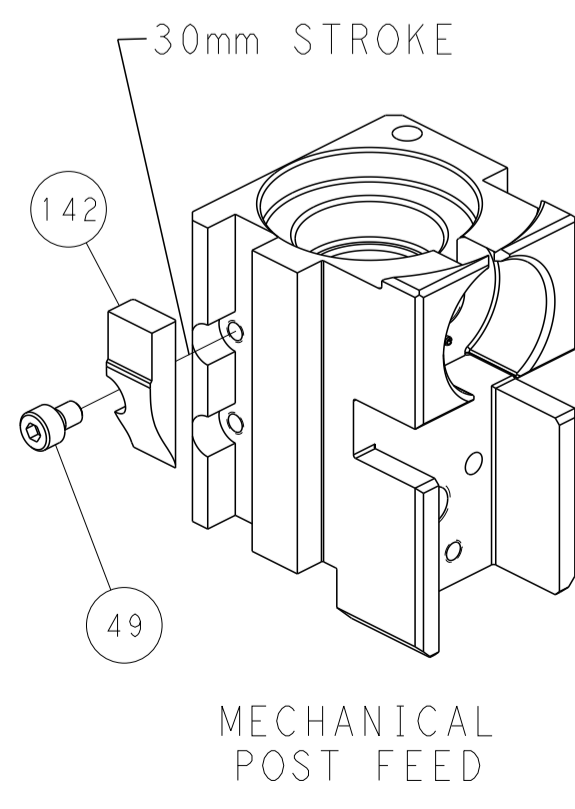

MECHANICAL POST FEED

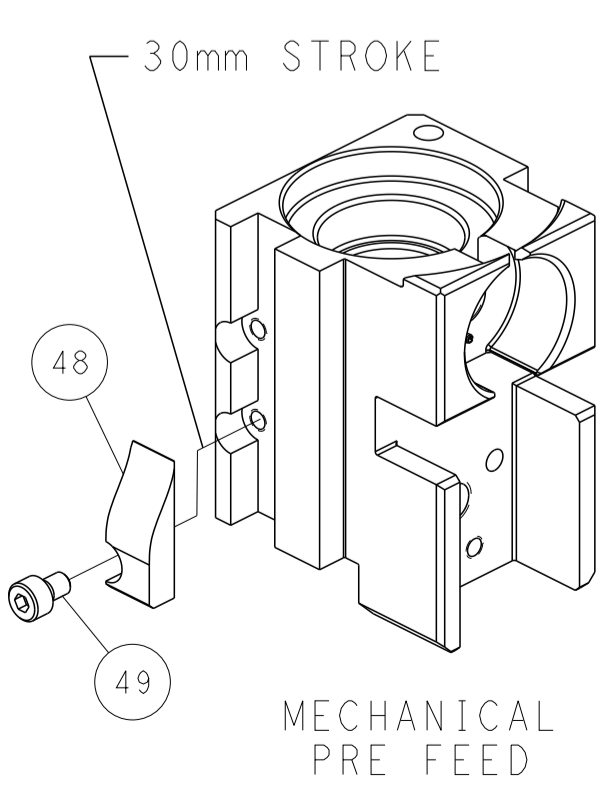

MECHANICAL PRE FEED

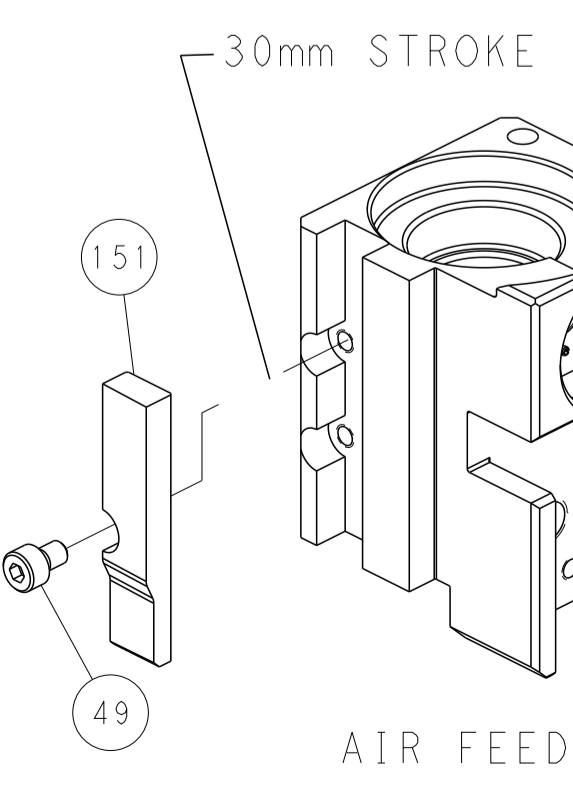

AIR FEED

PACIFIC VERSION
 Shown on sheets 3 of 4 & 4 of 4
 (Atlantic version shown on sheets 1 of 4 & 2 of 4)

<small>THIS DRAWING IS UNPUBLISHED. RELEASED FOR PUBLICATION. IT IS THE PROPERTY OF TYCO ELECTRONICS CORPORATION. IT IS TO BE USED ONLY FOR THE PURPOSES AND IN THE ORGANIZATION SPECIFIED. IT IS NOT TO BE REPRODUCED OR TRANSMITTED IN ANY FORM OR BY ANY MEANS, ELECTRONIC OR MECHANICAL, INCLUDING PHOTOCOPYING, RECORDING, OR BY ANY INFORMATION STORAGE AND RETRIEVAL SYSTEM, WITHOUT THE WRITTEN PERMISSION OF TYCO ELECTRONICS CORPORATION.</small>		DMN R. KNEPPER 16-Oct-13 CHK G. BAILEY 16-Oct-13 APVD M. CLIFFORD 16-Oct-13	NAME Ocean Side Feed Applicator
DIMENSIONS: mm TOLERANCES UNLESS OTHERWISE SPECIFIED: 0 PLC ± 1 PLC ± 2 PLC ± 3 PLC ± 4 PLC ± ANGLES ± FINISH	APPLICATION SPEC WEIGHT SCALE 1:2	SIZE CAGE CODE DRAWING NO A1 00779 C=2266119	RESTRICTED TO SHEET 4 OF 4 REV L