

1

2

3

4

5

6

7

A

A

B

B

C

C

D

D

E

E

F

F

G

G

H

H

LENGTH

12,0±0,3

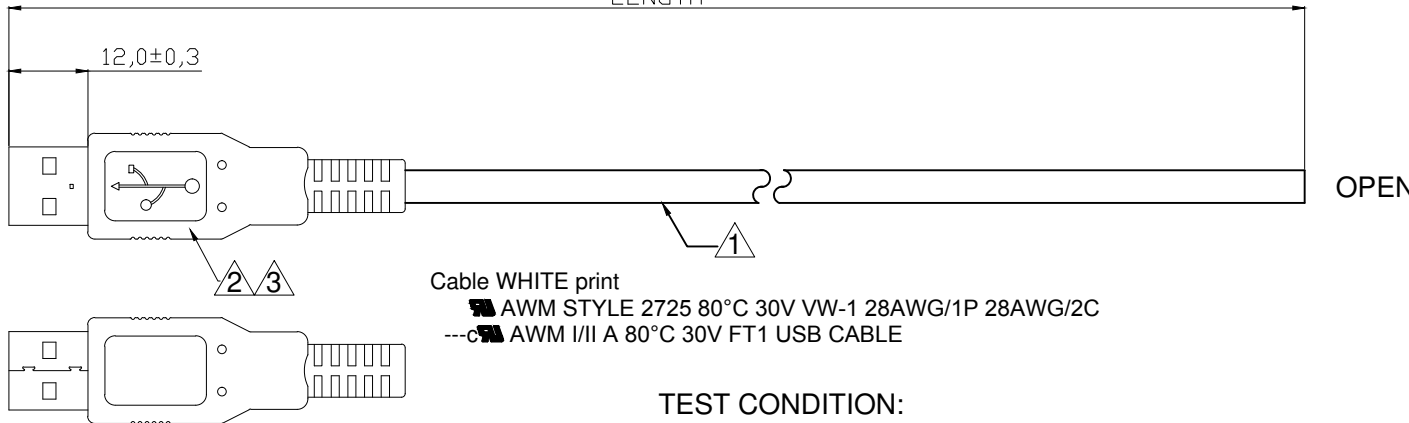
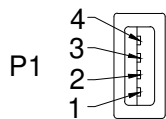

Cable WHITE print
 ---A AWM STYLE 2725 80°C 30V VW-1 28AWG/1P 28AWG/2C
 ---C AWM I/II A 80°C 30V FT1 USB CABLE

TEST CONDITION:
 1.100% OPEN, SHORT, MISWIRE TEST
 2.CONDUCT RESISTANCE : 2 Ω Max
 3.INSULATION RESISTANCE: 5M Ω Min
 4.Dielectric test:300V DC

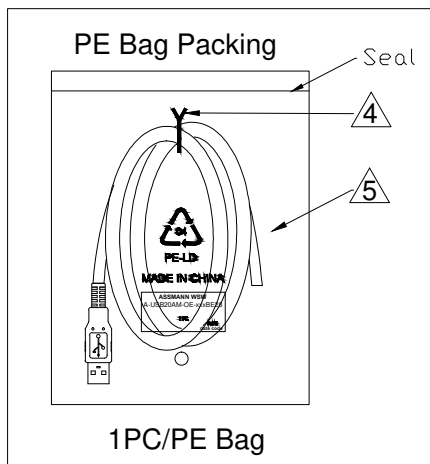

PIN ASSIGNMENT		
P1		OPEN
1	Red	OPEN
2	White	OPEN
3	Green	OPEN
4	Black	OPEN
Shell	Drain+Braid	OPEN

WSW P/N	Length(mm)	PE BAG SIZE
A-USB20AM-OE-050BE28	500±30	100*200*0.05mm
A-USB20AM-OE-100BE28	1000±30	100*200*0.05mm
A-USB20AM-OE-200BE28	2000±50	130*230*0.05mm
A-USB20AM-OE-300BE28	3000±50	130*230*0.05mm
A-USB20AM-OE-500BE28	5000±50	150*280*0.05mm

NO.	NAME.	Q'TY	SPECIFICATION
5	PE Bag	1	CLEAR PRINT BLACK"MADE IN CHINA"+"1PC."
4	TIE	1	white L=120mm
3	Over Molding	NA	PVC 45P Beige(BG002)
2	CONN	1	USB A MALE SHELL: Nickel PIN:G/F Insulator color:White
1	Cable	1	USB2.0 UL2725 28#/1P+28#/2C+AEB OD:3.8mm,PVC Jacket Beige(BG002)

RoHS compliant
 Unit: mm

Scale	Free				Date	Name	Customer-No.
TOLERANCE					Drawn	09.10.2018	Xavier
					Approved	09.10.2018	Winnie
DIM	TOL						
		①	Drawn	09.10.2018			
Angle	TOL	Id.	Modification	Date	Name	Replace	Sheet 1/2

ASSMANN WSW-No. A-USB20AM-OE-xxxBE28	
Drawing-No. ASS 8364 CA	rev00

1

2

3

4

5

6

7

Cable Wrapping Spec.

Cable Length(L)	Wrapping Dimension
L≤1M	W:80*L:100mm(MAX)
1M<L≤2M	W:85*L:105mm(MAX)
2M<L≤3M	W:120*L:150mm(MAX)
3M<L≤5M	W:150*L:180mm(MAX)

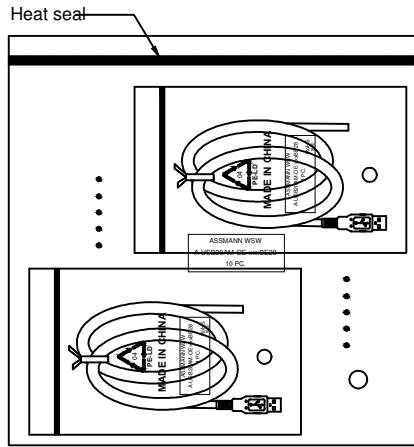
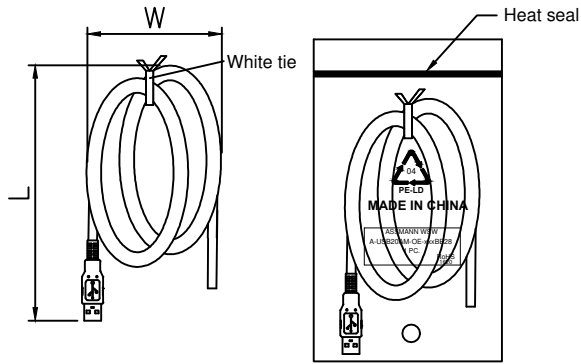

10PCS/Middle PE bag
Post 1PCS label on middle PE bag

Content of the label on middle PE bag:
ASSMANN WSW
A-USB20AM-OE-xxxBE28
10 PC.

Packing information:

- 1).Wrapping 1pcs cable, then tying.
- 2).Packing 1pcs finished goods into 1pcs small PE bag.
- 3).Packing 10pcs small PE bag into 1pcs middle PE bag.
- 4).Place 1pcs water-proof PE bag into carton and 1pcs paperboard in bottom and top of carton respectively.
- 5).Carton spec.: 40*30*25CM

Code label posted onto carton side

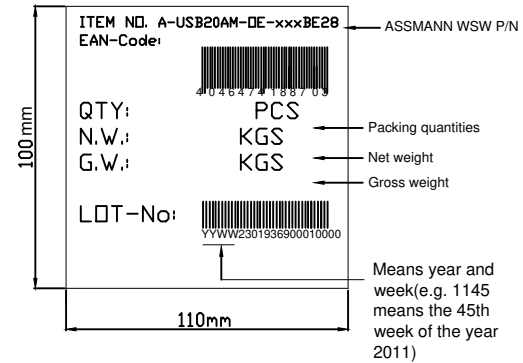

Code label posted onto left front corner of carton side x2 (on both side)

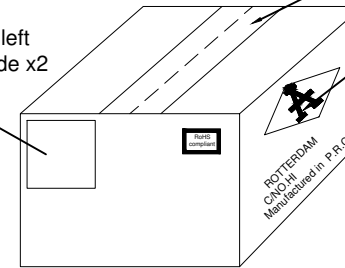

Content of the label on small PE bag:

ASSMANN WSW	Consistent
A-USB20AM-OE-xxxBE28	ASSMANN WSW P/N
1 PC.	Consistent
RoHS 1620	Consistent

NOTES: e.g. 1620-16 means Year 2016 , 20 means the 20th week of the year 2016

RoHS compliant
Unit: mm

Scale	Free				Date	Name	Customer-No.
TOLERANCE					Drawn	09.10.2018	Xavier
					Approved	09.10.2018	Winnie
DIM	TOL						ASSMANN WSW-No. A-USB20AM-OE-xxxBE28
		①	Drawn	09.10.2018	Xavier	Drawing-No. ASS 8364 CA rev00	
Angle	TOL	Id.	Modification	Date	Name	Replace	Sheet 2/2

