

ESP32-WROOM-DA

Datasheet

2.4 GHz Wi-Fi + Bluetooth® + Bluetooth LE module

Built around ESP32 series of SoCs, Xtensa® dual-core 32-bit LX6 microprocessor

8 MB flash

24 GPIOs, rich set of peripherals

On-board dual PCB antennas



ESP32-WROOM-DA



Preliminary v0.6
Espressif Systems
Copyright © 2023

1 Module Overview

Note:

Check the link or the QR code to make sure that you use the latest version of this document:
https://www.espressif.com/sites/default/files/documentation/esp32-wroom-da_datasheet_en.pdf



1.1 Features

CPU and On-Chip Memory

- ESP32-D0WD-V3 embedded, Xtensa® dual-core 32-bit LX6 microprocessor, up to 240 MHz
- 448 KB ROM for booting and core functions
- 520 KB SRAM for data and instructions
- 16 KB SRAM in RTC

Wi-Fi

- 802.11b/g/n
- Bit rate: 802.11n up to 150 Mbps
- A-MPDU and A-MSDU aggregation
- 0.4 μ s guard interval support
- Center frequency range of operating channel: 2412 ~ 2484 MHz

Bluetooth

- Bluetooth V4.2 BR/EDR and Bluetooth LE specification
- Class-1, class-2 and class-3 transmitter
- AFH
- CVSD and SBC

Peripherals

- SD card, UART, SPI, SDIO, I2C, LED PWM, Motor PWM, I2S, IR, pulse counter, GPIO, capacitive touch sensor, ADC, DAC, TWAI® (compatible with ISO 11898-1, i.e. CAN Specification 2.0)

Integrated Components on Module

- 40 MHz crystal oscillator
- 8 MB SPI flash

Antenna Options

- On-board dual PCB antennas

Operation Conditions

- Operating voltage/Power supply: 3.0 ~ 3.6 V
- Operating ambient temperature: -40 ~ 85 °C

Certification

- RF certification: See [Certificates](#)
- Green certification: REACH/RoHS

Test

- Reliability: HTOL/HTSL/uHAST/TCT/ESD

1.2 Description

ESP32-WROOM-DA is a powerful Wi-Fi + Bluetooth + Bluetooth LE MCU module, with two complementary PCB antennas in different directions. This module has the same layout of pins as ESP32-WROOM-32E except some pins are not led out, facilitating quick and easy migration between these two modules. With two unique antennas design on one single module, ESP32-WROOM-DA can be used to develop IoT applications that need stable connectivity over a broad spectrum, or to deploy Wi-Fi in challenging and hazardous environments, or to overcome communication problems in Wi-Fi-dead spots. This module is an ideal choice for indoor and outdoor devices for smart home, industrial control, consumer electronics, etc.

The ordering information of this module is listed as follows:

Table 1: Ordering Information

Module	Ordering Code	Chip Embedded	Flash	Module Dimensions (mm)
ESP32-WROOM-DA	ESP32-WROOM-DA-N8	ESP32-D0WD-V3	8 MB	35.6 x 34.4 x 3.5
Notes: 1. The module can be shipped with different flash sizes. 2. For details on the part numbers of the ESP32 series of chips, please refer to ESP32 Series Datasheet .				

At the core of the module is the ESP32-D0WD-V3 chip. The chip embedded is designed to be scalable and adaptive. There are two CPU cores that can be individually controlled, and the CPU clock frequency is adjustable from 80 MHz to 240 MHz. The chip also has a low-power coprocessor that can be used instead of the CPU to save power while performing tasks that do not require much computing power, such as monitoring of peripherals.

ESP32-D0WD-V3 integrates a rich set of peripherals, ranging from capacitive touch sensors, SD card interface, Ethernet, high-speed SPI, UART, I2S, and I2C.

1.3 Applications

- Generic Low-power IoT Sensor Hub
- Generic Low-power IoT Data Loggers
- Cameras for Video Streaming
- Over-the-top (OTT) Devices
- Speech Recognition
- Image Recognition
- Mesh Network
- Home Automation
- Smart Building
- Industrial Automation
- Smart Agriculture
- Audio Applications
- Health Care Applications
- Wi-Fi-enabled Toys
- Wearable Electronics
- Retail & Catering Applications

Contents

1	Module Overview	1
1.1	Features	1
1.2	Description	1
1.3	Applications	2
2	Block Diagram	7
3	Pin Definitions	8
3.1	Pin Layout	8
3.2	Pin Description	8
3.3	Strapping Pins	10
4	Electrical Characteristics	13
4.1	Absolute Maximum Ratings	13
4.2	Recommended Operating Conditions	13
4.3	DC Characteristics (3.3 V, 25 °C)	13
4.4	Current Consumption Characteristics	14
4.5	Wi-Fi RF Characteristics	15
4.5.1	Wi-Fi RF Standards	15
4.5.2	Transmitter Characteristics	15
4.5.3	Receiver Characteristics	16
4.6	Bluetooth Radio	17
4.6.1	Receiver – Basic Data Rate	17
4.6.2	Transmitter – Basic Data Rate	18
4.6.3	Receiver – Enhanced Data Rate	18
4.6.4	Transmitter – Enhanced Data Rate	19
4.7	Bluetooth LE Radio	19
4.7.1	Receiver	19
4.7.2	Transmitter	20
5	Module Schematics	21
6	Peripheral Schematics	22
7	Physical Dimensions and PCB Land Pattern	23
7.1	Physical Dimensions	23
7.2	Recommended PCB Land Pattern	24
8	Product Handling	25
8.1	Storage Conditions	25
8.2	Electrostatic Discharge (ESD)	25
8.3	Reflow Profile	25
8.4	Ultrasonic Vibration	26

9 Related Documentation and Resources	27
Revision History	28

List of Tables

1	Ordering Information	2
2	Pin Definitions	8
3	Select Working Antenna	10
4	Strapping Pins	11
5	Parameter Descriptions of Setup and Hold Times for the Strapping Pins	12
6	Absolute Maximum Ratings	13
7	Recommended Operating Conditions	13
8	DC Characteristics (3.3 V, 25 °C)	13
9	Current Consumption Depending on RF Modes	14
10	Current Consumption Depending on Work Modes	14
11	Wi-Fi RF Standards	15
12	TX Power Characteristics	16
13	RX Sensitivity Characteristics	16
14	RX Maximum Input Level	17
15	Adjacent Channel Rejection	17
16	Receiver Characteristics – Basic Data Rate	17
17	Transmitter Characteristics – Basic Data Rate	18
18	Receiver Characteristics – Enhanced Data Rate	18
19	Transmitter Characteristics – Enhanced Data Rate	19
20	Receiver Characteristics – BLE	20
21	Transmitter Characteristics – BLE	20

List of Figures

1	ESP32-WROOM-DA Block Diagram	7
2	Pin Layout (Top View)	8
3	Setup and Hold Times for the Strapping Pins	11
4	ESP32-WROOM-DA Schematics	21
5	Peripheral Schematics	22
6	Physical Dimensions	23
7	Recommended PCB Land Pattern	24
8	Reflow Profile	25

2 Block Diagram

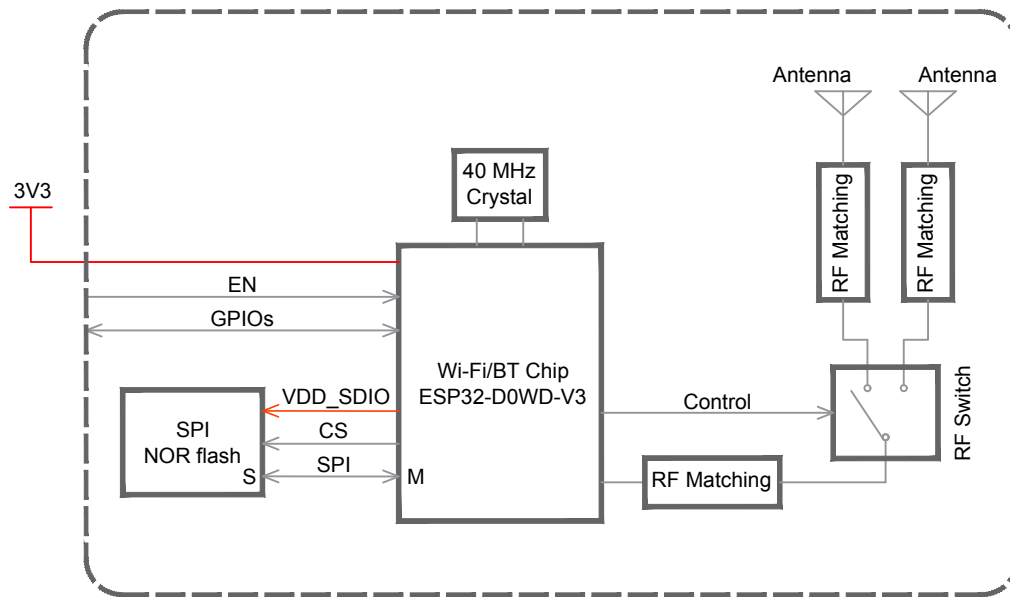

Figure 1: ESP32-WROOM-DA Block Diagram

3 Pin Definitions

3.1 Pin Layout

The pin diagram below shows the approximate location of pins on the module. For the actual diagram drawn to scale, please refer to Figure 7.1 *Physical Dimensions*.

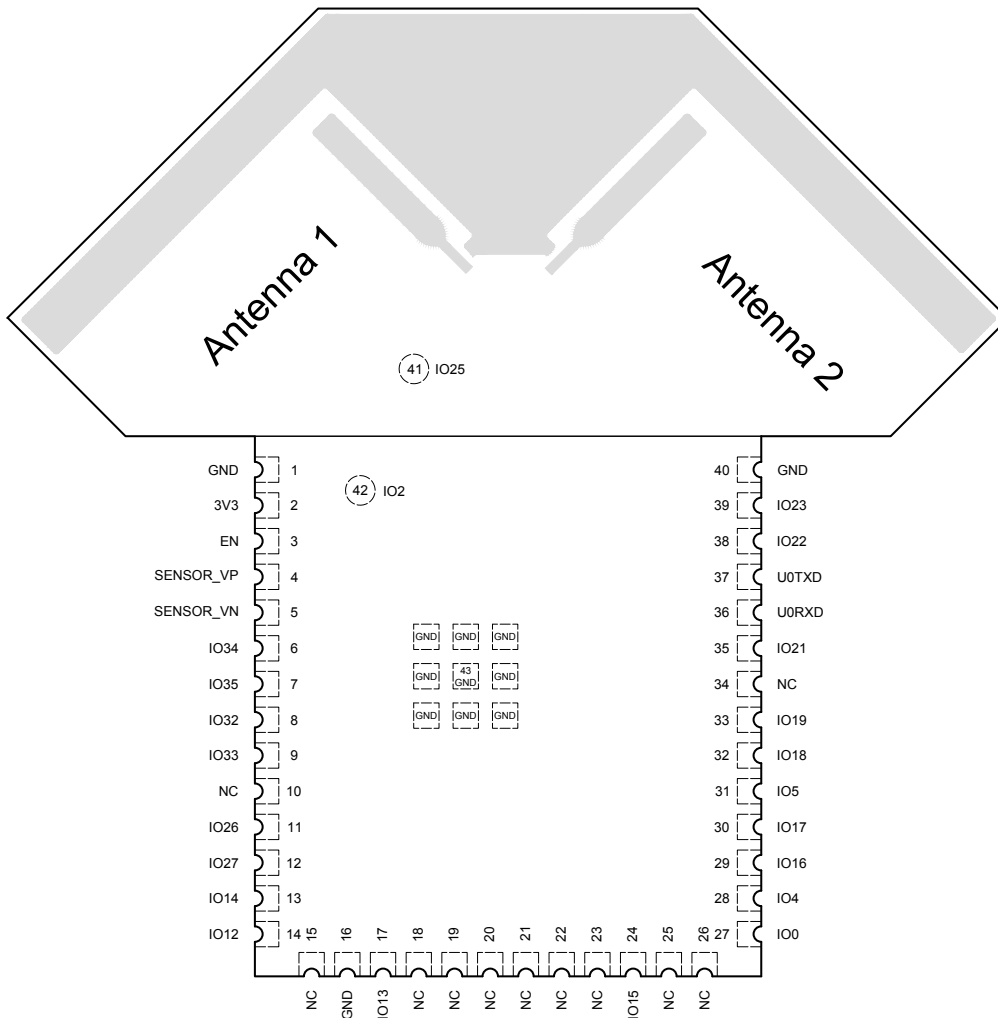

Figure 2: Pin Layout (Top View)

3.2 Pin Description

The module has 41 pins and two test points. See pin definitions in Table 2.

Table 2: Pin Definitions

Name	No.	Type	Function ²
GND	1	P	Ground
3V3	2	P	Power supply

Cont'd on next page

Table 2 – cont'd from previous page

Name	No.	Type	Function ²
EN	3	I	High: On; enables the chip Low: Off; the chip shuts down Note: Do not leave the pin floating.
SENSOR_VP	4	I	GPIO36, ADC1_CH0, RTC_GPIO0
SENSOR_VN	5	I	GPIO39, ADC1_CH3, RTC_GPIO3
IO34	6	I	GPIO34, ADC1_CH6, RTC_GPIO4
IO35	7	I	GPIO35, ADC1_CH7, RTC_GPIO5
IO32	8	I/O	GPIO32, XTAL_32K_P (32.768 kHz crystal oscillator input), ADC1_CH4, TOUCH9, RTC_GPIO9
IO33	9	I/O	GPIO33, XTAL_32K_N (32.768 kHz crystal oscillator output), ADC1_CH5, TOUCH8, RTC_GPIO8
NC	10	—	—
IO26	11	I/O	GPIO26, DAC_2, ADC2_CH9, RTC_GPIO7, EMAC_RXD1
IO27	12	I/O	GPIO27, ADC2_CH7, TOUCH7, RTC_GPIO17, EMAC_RX_DV
IO14	13	I/O	GPIO14, ADC2_CH6, TOUCH6, RTC_GPIO16, MTMS, HSPICLK, HS2_CLK, SD_CLK, EMAC_TXD2
IO12	14	I/O	GPIO12, ADC2_CH5, TOUCH5, RTC_GPIO15, MTDI, HSPIQ, HS2_DATA2, SD_DATA2, EMAC_TXD3
NC	15	—	—
GND	16	P	Ground
IO13	17	I/O	GPIO13, ADC2_CH4, TOUCH4, RTC_GPIO14, MTCK, HSPID, HS2_DATA3, SD_DATA3, EMAC_RX_ER
NC	18	—	—
NC	19	—	—
NC	20	—	—
NC	21	—	—
NC	22	—	—
NC	23	—	—
IO15	24	I/O	GPIO15, ADC2_CH3, TOUCH3, MTDO, HSPICS0, RTC_GPIO13, HS2_CMD, SD_CMD, EMAC_RXD3
NC	25	—	—
NC	26	—	—
IO0	27	I/O	GPIO0, ADC2_CH1, TOUCH1, RTC_GPIO11, CLK_OUT1, EMAC_TX_CLK
IO4	28	I/O	GPIO4, ADC2_CH0, TOUCH0, RTC_GPIO10, HSPiHD, HS2_DATA1, SD_DATA1, EMAC_TX_ER
IO16	29	I/O	GPIO16, HS1_DATA4, U2RXD, EMAC_CLK_OUT
IO17	30	I/O	GPIO17, HS1_DATA5, U2TXD, EMAC_CLK_OUT_180
IO5	31	I/O	GPIO5, VSPICS0, HS1_DATA6, EMAC_RX_CLK
IO18	32	I/O	GPIO18, VSPICLK, HS1_DATA7
IO19	33	I/O	GPIO19, VSPIQ, U0CTS, EMAC_TXD0
NC	34	—	—

Cont'd on next page

Table 2 – cont'd from previous page

Name	No.	Type	Function ²
IO21	35	I/O	GPIO21, VSPIHD, EMAC_TX_EN
U0RXD	36	I/O	GPIO3, U0RXD, CLK_OUT2
U0TXD	37	I/O	GPIO1, U0TXD, CLK_OUT3, EMAC_RXD2
IO22	38	I/O	GPIO22, VSPIWP, U0RTS, EMAC_TXD1
IO23	39	I/O	GPIO23, VSPID, HS1_STROBE
GND	40	P	Ground
NC ³	41	—	—
NC ³	42	—	—
GND	43	P	Ground

¹ For peripheral pin configurations, please refer to [ESP32 Series Datasheet](#).

² GPIO2 and GPIO25 on the ESP32-D0WD-V3 chip are designed as test points to control RF Switch (See Figure 4 [ESP32-WROOM-DA Schematics](#)). The two pins are not led out to the module. To select the working antenna, (Antenna 1 or Antenna 2), configure GPIO2 and GPIO25 as follows:

Table 3: Select Working Antenna

Working Antenna	GPIO2	GPIO25
Antenna 1	High	Low
Antenna 2 (by default)	Low	High

3.3 Strapping Pins

Note:

The content below is excerpted from Section Strapping Pins in [ESP32 Series Datasheet](#). For the strapping pin mapping between the chip and modules, please refer to Chapter 5 [Module Schematics](#).

ESP32 has five strapping pins:

- MTDI
- GPIO0
- GPIO2
- MTDO
- GPIO5

Software can read the values of these five bits from register "GPIO_STRAPPING".

During the chip's system reset release (power-on-reset, RTC watchdog reset and brownout reset), the latches of the strapping pins sample the voltage level as strapping bits of "0" or "1", and hold these bits until the chip is powered down or shut down. The strapping bits configure the device's boot mode, the operating voltage of VDD_SDIO and other initial system settings.

Each strapping pin is connected to its internal pull-up/pull-down during the chip reset. Consequently, if a strapping pin is unconnected or the connected external circuit is high-impedance, the internal weak pull-up/pull-down will determine the default input level of the strapping pins.

To change the strapping bit values, users can apply the external pull-down/pull-up resistances, or use the host MCU's GPIOs to control the voltage level of these pins when powering on ESP32.

After reset release, the strapping pins work as normal-function pins.

Refer to Table 4 for a detailed boot-mode configuration by strapping pins.

Table 4: Strapping Pins

Voltage of Internal LDO (VDD_SDIO)					
Pin	Default	3.3 V		1.8 V	
MTDI	Pull-down	0		1	
Bootling Mode					
Pin	Default	SPI Boot		Download Boot	
GPIO0	Pull-up	1		0	
GPIO2	Pull-down	Don't-care		0	
Enabling/Disabling Debugging Log Print over U0TXD During Bootling					
Pin	Default	U0TXD Active		U0TXD Silent	
MTDO	Pull-up	1		0	
Timing of SDIO Slave					
Pin	Default	FE Sampling FE Output	FE Sampling RE Output	RE Sampling FE Output	RE Sampling RE Output
MTDO	Pull-up	0	0	1	1
GPIO5	Pull-up	0	1	0	1

* FE: falling-edge, RE: rising-edge

* Firmware can configure register bits to change the settings of "Voltage of Internal LDO (VDD_SDIO)" and "Timing of SDIO Slave", after bootling.

* The module integrates a 3.3 V SPI flash, so the pin MTDI cannot be set to 1 when the module is powered up.

The illustration below shows the setup and hold times for the strapping pins before and after the CHIP_PU signal goes high. Details about the parameters are listed in Table 5.

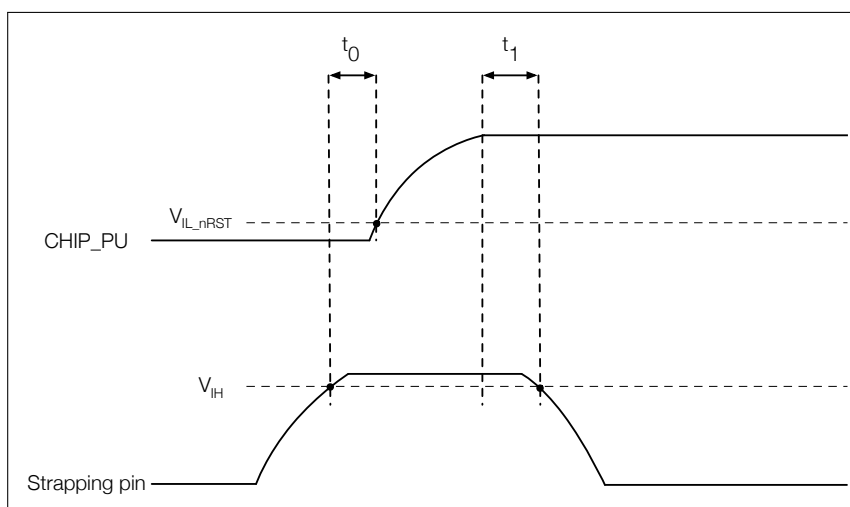

Figure 3: Setup and Hold Times for the Strapping Pins

Table 5: Parameter Descriptions of Setup and Hold Times for the Strapping Pins

Parameters	Description	Min.	Unit
t_0	Setup time before CHIP_PU goes from low to high	0	ms
t_1	Hold time after CHIP_PU goes high	1	ms

4 Electrical Characteristics

4.1 Absolute Maximum Ratings

Stresses beyond the absolute maximum ratings listed in the table below may cause permanent damage to the device. These are stress ratings only, and do not refer to the functional operation of the device that should follow the [recommended operating conditions](#).

Table 6: Absolute Maximum Ratings

Symbol	Parameter	Min	Max	Unit
VDD33	Power supply voltage	-0.3	3.6	V
T _{STORE}	Storage temperature	-40	105	°C

* Please see Appendix IO_MUX of [ESP32 Series Datasheet](#) for IO's power domain.

4.2 Recommended Operating Conditions

Table 7: Recommended Operating Conditions

Symbol	Parameter	Min	Typ	Max	Unit
VDD33	Power supply voltage	3.0	3.3	3.6	V
I _{VDD}	Current delivered by external power supply	0.5	—	—	A
T	Operating ambient temperature	-40	—	85	°C

4.3 DC Characteristics (3.3 V, 25 °C)

Table 8: DC Characteristics (3.3 V, 25 °C)

Symbol	Parameter	Min	Typ	Max	Unit	
C _{IN}	Pin capacitance	—	2	—	pF	
V _{IH}	High-level input voltage	0.75 × VDD ¹	—	VDD ¹ + 0.3	V	
V _{IL}	Low-level input voltage	-0.3	—	0.25 × VDD ¹	V	
I _{IH}	High-level input current	—	—	50	nA	
I _{IL}	Low-level input current	—	—	50	nA	
V _{OH}	High-level output voltage	0.8 × VDD ¹	—	—	V	
V _{OL}	Low-level output voltage	—	—	0.1 × VDD ¹	V	
I _{OH}	High-level source current (VDD ¹ = 3.3 V, V _{OH} ≥ 2.64 V, output drive strength set to the maximum)	VDD3P3_CPU power domain ^{1, 2}	—	40	—	mA
		VDD3P3_RTC power domain ^{1, 2}	—	40	—	mA
		VDD_SDIO power domain ^{1, 3}	—	20	—	mA

Cont'd on next page

Table 8 – cont'd from previous page

Symbol	Parameter	Min	Typ	Max	Unit
I_{OL}	Low-level sink current ($V_{DD}^1 = 3.3\text{ V}$, $V_{OL} = 0.495\text{ V}$, output drive strength set to the maximum)	—	28	—	mA
R_{PU}	Resistance of internal pull-up resistor	—	45	—	$k\Omega$
R_{PD}	Resistance of internal pull-down resistor	—	45	—	$k\Omega$
V_{IL_nRST}	Low-level input voltage of CHIP_PU to shut down the chip	—	—	0.6	V

¹ Please see Appendix IO_MUX of [ESP32 Series Datasheet](#) for IO's power domain. VDD is the I/O voltage for a particular power domain of pins.

² For VDD3P3_CPU and VDD3P3_RTC power domain, per-pin current sourced in the same domain is gradually reduced from around 40 mA to around 29 mA, $V_{OH} \geq 2.64\text{ V}$, as the number of current-source pins increases.

³ Pins occupied by flash and/or PSRAM in the VDD_SDIO power domain were excluded from the test.

4.4 Current Consumption Characteristics

With the use of advanced power-management technologies, ESP32 can switch between different power modes.

For details on ESP32's power consumption in different power modes, please refer to section "RTC and Low-Power Management" in [ESP32 Series Datasheet](#).

Table 9: Current Consumption Depending on RF Modes

Work mode	Description	Peak (mA)	
Active (RF working)	TX	802.11b, 20 MHz, 1 Mbps, @19.5 dBm	379
		802.11g, 20 MHz, 54 Mbps, @15 dBm	276
		802.11n, 20 MHz, MCS7, @13 dBm	258
		802.11n, 40 MHz, MCS7, @13 dBm	211
	RX	802.11b/g/n, 20 MHz	112
		802.11n, 40 MHz	118

* The current consumption measurements are taken with a 3.3 V supply at 25 °C of ambient temperature at the RF port. All transmitters' measurements are based on a 100% duty cycle.

* The current consumption figures for in RX mode are for cases when the peripherals are disabled and the CPU idle.

Table 10: Current Consumption Depending on Work Modes

Work mode	Description	Current consumption (Typ)	
Modem-sleep ^{1,2}	The CPU is powered up ³	240 MHz	30 ~ 68 mA
		160 MHz	27 ~ 44 mA
		Normal speed: 80 MHz	20 ~ 31 mA
Light-sleep	—	0.8 mA	

Work mode	Description	Current consumption (Typ)
Deep-sleep	The ULP coprocessor is powered up ⁴	150 μ A
	ULP sensor-monitored pattern ⁵	100 μ A @1% duty
	RTC timer + RTC memory	10 μ A
	RTC timer only	5 μ A
Power off	CHIP_PU is set to low level, the chip is powered down	1 μ A

¹ The current consumption figures in Modem-sleep mode are for cases where the CPU is powered up and the cache idle.

² When Wi-Fi is enabled, the chip switches between Active and Modem-sleep modes. Therefore, current consumption changes accordingly.

³ In Modem-sleep mode, the CPU frequency changes automatically. The frequency depends on the CPU load and the peripherals used.

⁴ During Deep-sleep, when the ULP coprocessor is powered on, peripherals such as GPIO and RTC I2C are able to operate.

⁵ The "ULP sensor-monitored pattern" refers to the mode where the ULP coprocessor or the sensor works periodically. When ADC works with a duty cycle of 1%, the typical current consumption is 100 μ A.

4.5 Wi-Fi RF Characteristics

4.5.1 Wi-Fi RF Standards

Table 11: Wi-Fi RF Standards

Name		Description
Center frequency range of operating channel*		2412 ~ 2484 MHz
Wi-Fi wireless standard		IEEE 802.11b/g/n
Data rate	20 MHz	11b: 1, 2, 5.5 and 11 Mbps 11g: 6, 9, 12, 18, 24, 36, 48, 54 Mbps 11n: MCS0-7, 72.2 Mbps (Max)
	40 MHz	11n: MCS0-7, 150 Mbps (Max)
Antenna type		PCB antenna

* Device should operate in the center frequency range allocated by regional regulatory authorities. Target center frequency range is configurable by software.

4.5.2 Transmitter Characteristics

Target TX power is configurable based on device or certification requirements. The default characteristics are provided in Table 12.

Table 12: TX Power Characteristics

Rate	Typ (dBm)
11b, 1 Mbps	19.5
11b, 11 Mbps	19.5
11g, 6 Mbps	18
11g, 54 Mbps	14
11n, HT20, MCS0	18
11n, HT20, MCS7	13
11n, HT40, MCS0	18
11n, HT40, MCS7	13

4.5.3 Receiver Characteristics

Table 13: RX Sensitivity Characteristics

Rate	Typ (dBm)
1 Mbps	-97
2 Mbps	-94
5.5 Mbps	-92
11 Mbps	-88
6 Mbps	-93
9 Mbps	-91
12 Mbps	-89
18 Mbps	-87
24 Mbps	-84
36 Mbps	-80
48 Mbps	-77
54 Mbps	-75
11n, HT20, MCS0	-92
11n, HT20, MCS1	-88
11n, HT20, MCS2	-86
11n, HT20, MCS3	-83
11n, HT20, MCS4	-80
11n, HT20, MCS5	-76
11n, HT20, MCS6	-74
11n, HT20, MCS7	-72
11n, HT40, MCS0	-89
11n, HT40, MCS1	-85
11n, HT40, MCS2	-83
11n, HT40, MCS3	-80
11n, HT40, MCS4	-76
11n, HT40, MCS5	-72
11n, HT40, MCS6	-71

Cont'd on next page

Table 13 – cont'd from previous page

Rate	Typ (dBm)
11n, HT40, MCS7	-69

Table 14: RX Maximum Input Level

Rate	Typ (dBm)
11b, 1 Mbps	5
11b, 11 Mbps	5
11g, 6 Mbps	0
11g, 54 Mbps	-8
11n, HT20, MCS0	0
11n, HT20, MCS7	-8
11n, HT40, MCS0	0
11n, HT40, MCS7	-8

Table 15: Adjacent Channel Rejection

Rate	Typ (dB)
11b, 11 Mbps	35
11g, 6 Mbps	27
11g, 54 Mbps	13
11n, HT20, MCS0	27
11n, HT20, MCS7	12
11n, HT40, MCS0	16
11n, HT40, MCS7	7

4.6 Bluetooth Radio

4.6.1 Receiver – Basic Data Rate

Table 16: Receiver Characteristics – Basic Data Rate

Parameter	Conditions	Min	Typ	Max	Unit
Sensitivity @0.1% BER	—	-90	-89	-88	dBm
Maximum received signal @0.1% BER	—	0	—	—	dBm
Co-channel C/I	—	—	+7	—	dB
Adjacent channel selectivity C/I	F = F0 + 1 MHz	—	—	-6	dB
	F = F0 - 1 MHz	—	—	-6	dB
	F = F0 + 2 MHz	—	—	-25	dB
	F = F0 - 2 MHz	—	—	-33	dB
	F = F0 + 3 MHz	—	—	-25	dB
	F = F0 - 3 MHz	—	—	-45	dB

Cont'd on next page

Table 16 – cont'd from previous page

Parameter	Conditions	Min	Typ	Max	Unit
Out-of-band blocking performance	30 MHz ~ 2000 MHz	-10	—	—	dBm
	2000 MHz ~ 2400 MHz	-27	—	—	dBm
	2500 MHz ~ 3000 MHz	-27	—	—	dBm
	3000 MHz ~ 12.5 GHz	-10	—	—	dBm
Intermodulation	—	-36	—	—	dBm

4.6.2 Transmitter – Basic Data Rate

Table 17: Transmitter Characteristics – Basic Data Rate

Parameter	Conditions	Min	Typ	Max	Unit
RF transmit power*	-	-	0	-	dBm
Gain control step	-	-	3	-	dB
RF power control range	-	-12	-	+9	dBm
+20 dB bandwidth	-	-	0.9	-	MHz
Adjacent channel transmit power	F = F0 ± 2 MHz	-	-55	-	dBm
	F = F0 ± 3 MHz	-	-55	-	dBm
	F = F0 ± > 3 MHz	-	-59	-	dBm
Δf_{1avg}	-	-	-	155	kHz
Δf_{2max}	-	127	-	-	kHz
$\Delta f_{2avg}/\Delta f_{1avg}$	-	-	0.92	-	-
ICFT	-	-	-7	-	kHz
Drift rate	-	-	0.7	-	kHz/50 μ s
Drift (DH1)	-	-	6	-	kHz
Drift (DH5)	-	-	6	-	kHz

* There are a total of eight power levels from 0 to 7, and the transmit power ranges from -12 dBm to 9 dBm. When the power level rises by 1, the transmit power increases by 3 dB. Power level 4 is used by default and the corresponding transmit power is 0 dBm.

4.6.3 Receiver – Enhanced Data Rate

Table 18: Receiver Characteristics – Enhanced Data Rate

Parameter	Conditions	Min	Typ	Max	Unit
$\pi/4$ DQPSK					
Sensitivity @0.01% BER	—	-90	-89	-88	dBm
Maximum received signal @0.01% BER	—	—	0	—	dBm
Co-channel C/I	—	—	11	—	dB
Adjacent channel selectivity C/I	F = F0 + 1 MHz	—	-7	—	dB
	F = F0 - 1 MHz	—	-7	—	dB
	F = F0 + 2 MHz	—	-25	—	dB
	F = F0 - 2 MHz	—	-35	—	dB
	F = F0 + 3 MHz	—	-25	—	dB

Cont'd on next page

Table 18 – cont'd from previous page

Parameter	Conditions	Min	Typ	Max	Unit
	F = F0 – 3 MHz	—	-45	—	dB
8DPSK					
Sensitivity @0.01% BER	—	-84	-83	-82	dBm
Maximum received signal @0.01% BER	—	—	-5	—	dBm
C/I c-channel	—	—	18	—	dB
Adjacent channel selectivity C/I	F = F0 + 1 MHz	—	2	—	dB
	F = F0 – 1 MHz	—	2	—	dB
	F = F0 + 2 MHz	—	-25	—	dB
	F = F0 – 2 MHz	—	-25	—	dB
	F = F0 + 3 MHz	—	-25	—	dB
	F = F0 – 3 MHz	—	-38	—	dB

4.6.4 Transmitter – Enhanced Data Rate

Table 19: Transmitter Characteristics – Enhanced Data Rate

Parameter	Conditions	Min	Typ	Max	Unit
RF transmit power (see note under Table 17)	—	—	0	—	dBm
Gain control step	—	—	3	—	dB
RF power control range	—	-12	—	+9	dBm
$\pi/4$ DQPSK max w0	—	—	-0.72	—	kHz
$\pi/4$ DQPSK max wi	—	—	-6	—	kHz
$\pi/4$ DQPSK max wi + w0	—	—	-7.42	—	kHz
8DPSK max w0	—	—	0.7	—	kHz
8DPSK max wi	—	—	-9.6	—	kHz
8DPSK max wi + w0	—	—	-10	—	kHz
$\pi/4$ DQPSK modulation accuracy	RMS DEVM	—	4.28	—	%
	99% DEVM	—	100	—	%
	Peak DEVM	—	13.3	—	%
8 DPSK modulation accuracy	RMS DEVM	—	5.8	—	%
	99% DEVM	—	100	—	%
	Peak DEVM	—	14	—	%
In-band spurious emissions	F = F0 ± 1 MHz	—	-46	—	dBm
	F = F0 ± 2 MHz	—	-44	—	dBm
	F = F0 ± 3 MHz	—	-49	—	dBm
	F = F0 +/- > 3 MHz	—	—	-53	dBm
EDR differential phase coding	—	—	100	—	%

4.7 Bluetooth LE Radio

4.7.1 Receiver

Table 20: Receiver Characteristics – BLE

Parameter	Conditions	Min	Typ	Max	Unit
Sensitivity @30.8% PER	—	-94	-93	-92	dBm
Maximum received signal @30.8% PER	—	0	—	—	dBm
Co-channel C/I	—	—	+10	—	dB
Adjacent channel selectivity C/I	F = F0 + 1 MHz	—	-5	—	dB
	F = F0 - 1 MHz	—	-5	—	dB
	F = F0 + 2 MHz	—	-25	—	dB
	F = F0 - 2 MHz	—	-35	—	dB
	F = F0 + 3 MHz	—	-25	—	dB
	F = F0 - 3 MHz	—	-45	—	dB
Out-of-band blocking performance	30 MHz ~ 2000 MHz	-10	—	—	dBm
	2000 MHz ~ 2400 MHz	-27	—	—	dBm
	2500 MHz ~ 3000 MHz	-27	—	—	dBm
	3000 MHz ~ 12.5 GHz	-10	—	—	dBm
Intermodulation	—	-36	—	—	dBm

4.7.2 Transmitter

Table 21: Transmitter Characteristics – BLE

Parameter	Conditions	Min	Typ	Max	Unit
RF transmit power (see note under Table 17)	—	—	0	—	dBm
Gain control step	—	—	3	—	dB
RF power control range	—	-12	—	+9	dBm
Adjacent channel transmit power	F = F0 ± 2 MHz	—	-55	—	dBm
	F = F0 ± 3 MHz	—	-57	—	dBm
	F = F0 ± > 3 MHz	—	-59	—	dBm
$\Delta f_{1_{avg}}$	—	—	—	265	kHz
$\Delta f_{2_{max}}$	—	210	—	—	kHz
$\Delta f_{2_{avg}}/\Delta f_{1_{avg}}$	—	—	+0.92	—	—
ICFT	—	—	-10	—	kHz
Drift rate	—	—	0.7	—	kHz/50 μ s
Drift	—	—	2	—	kHz

5 Module Schematics

This is the reference design of the module.

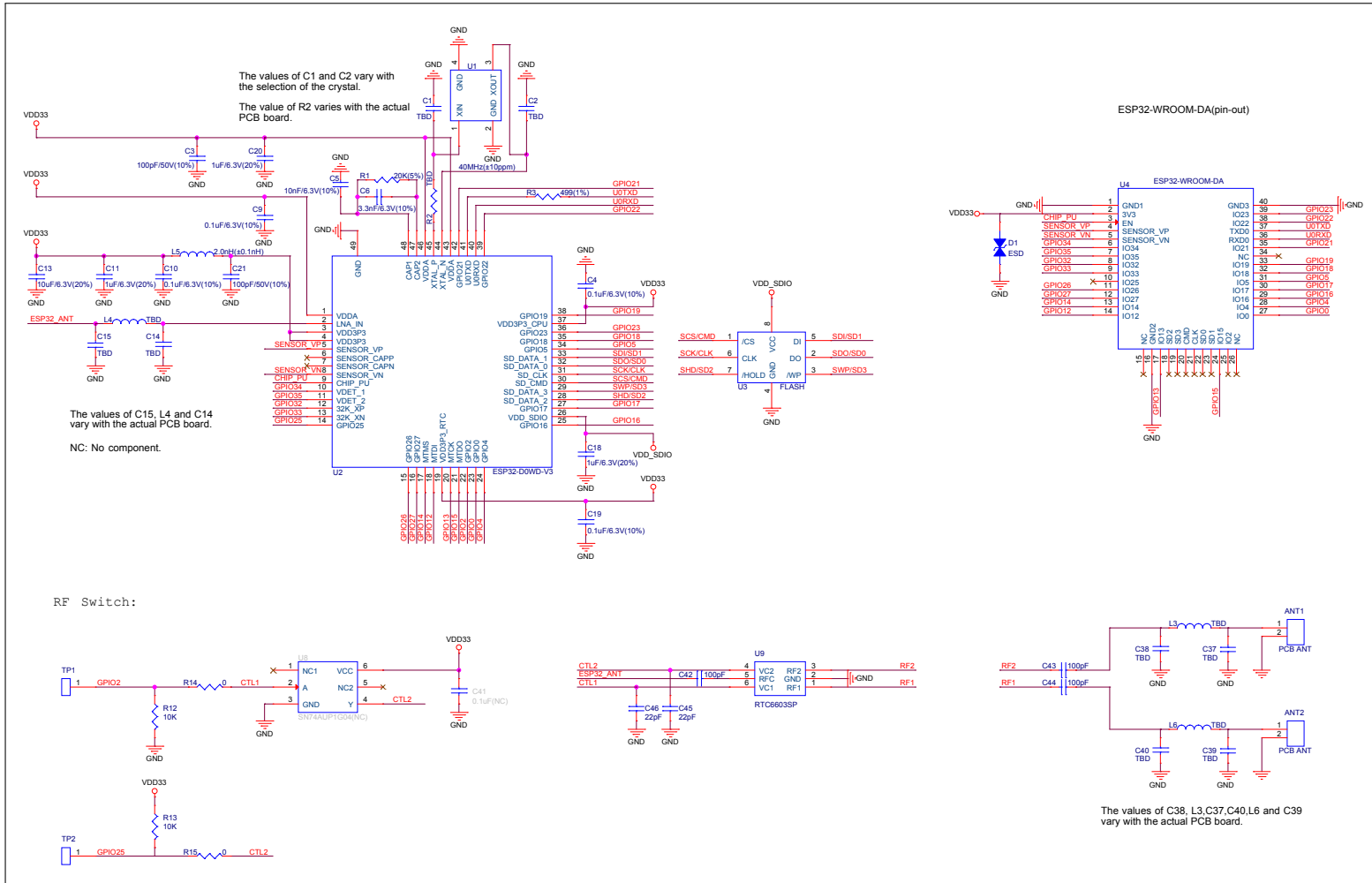

Figure 4: ESP32-WROOM-DA Schematics

6 Peripheral Schematics

This is the typical application circuit of the module connected with peripheral components (for example, power supply, antenna, reset button, JTAG interface, and UART interface).

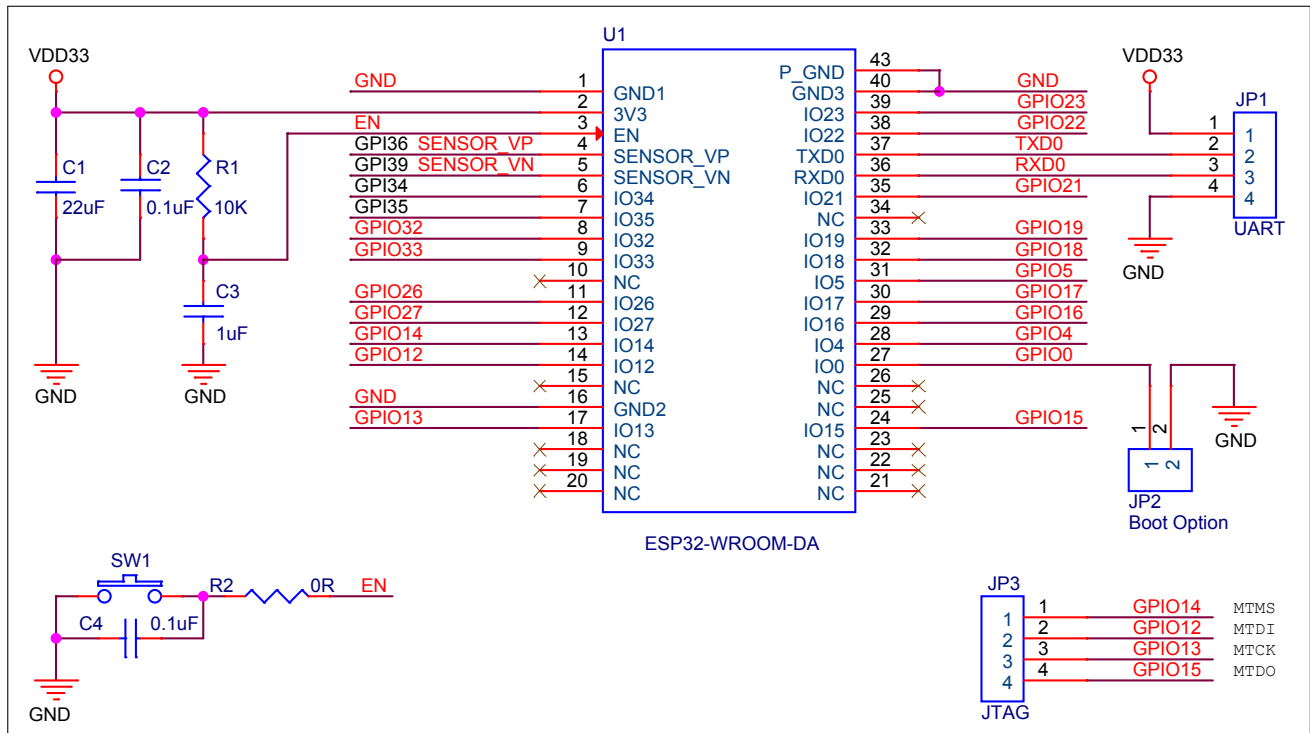

Figure 5: Peripheral Schematics

Note:

- Soldering Pad 43 to the Ground of the base board is not necessary for a satisfactory thermal performance. If users do want to solder it, they need to ensure that the correct quantity of soldering paste is applied.
- To ensure the power supply to the ESP32 chip during power-up, it is advised to add an RC delay circuit at the EN pin. The recommended setting for the RC delay circuit is usually $R = 10\text{ k}\Omega$ and $C = 1\ \mu\text{F}$. However, specific parameters should be adjusted based on the power-up timing of the module and the power-up and reset sequence timing of the chip. For ESP32's power-up and reset sequence timing diagram, please refer to Section *Power Scheme* in [ESP32 Series Datasheet](#).

7 Physical Dimensions and PCB Land Pattern

7.1 Physical Dimensions

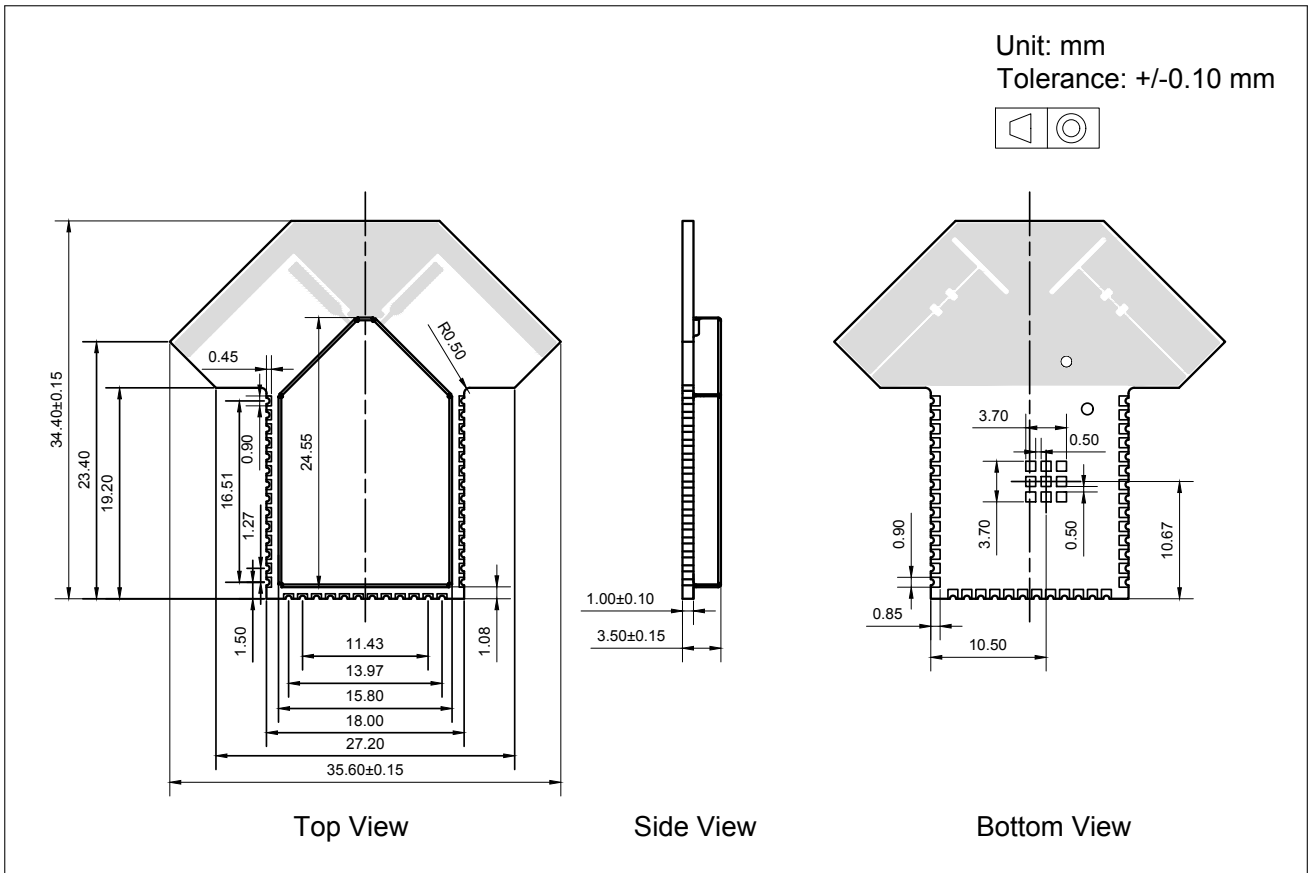

Figure 6: Physical Dimensions

Note:

For information about tape, reel, and product marking, please refer to [Espressif Module Package Information](#).

7.2 Recommended PCB Land Pattern

This section provides the following resources for your reference:

- Figures for recommended PCB land patterns with all the dimensions needed for PCB design. See Figure 7 [Recommended PCB Land Pattern](#).
- Source files of recommended PCB land patterns to measure dimensions not covered in Figure 7. You can view the source files for [ESP32-WROOM-DA](#) with [Autodesk Viewer](#).

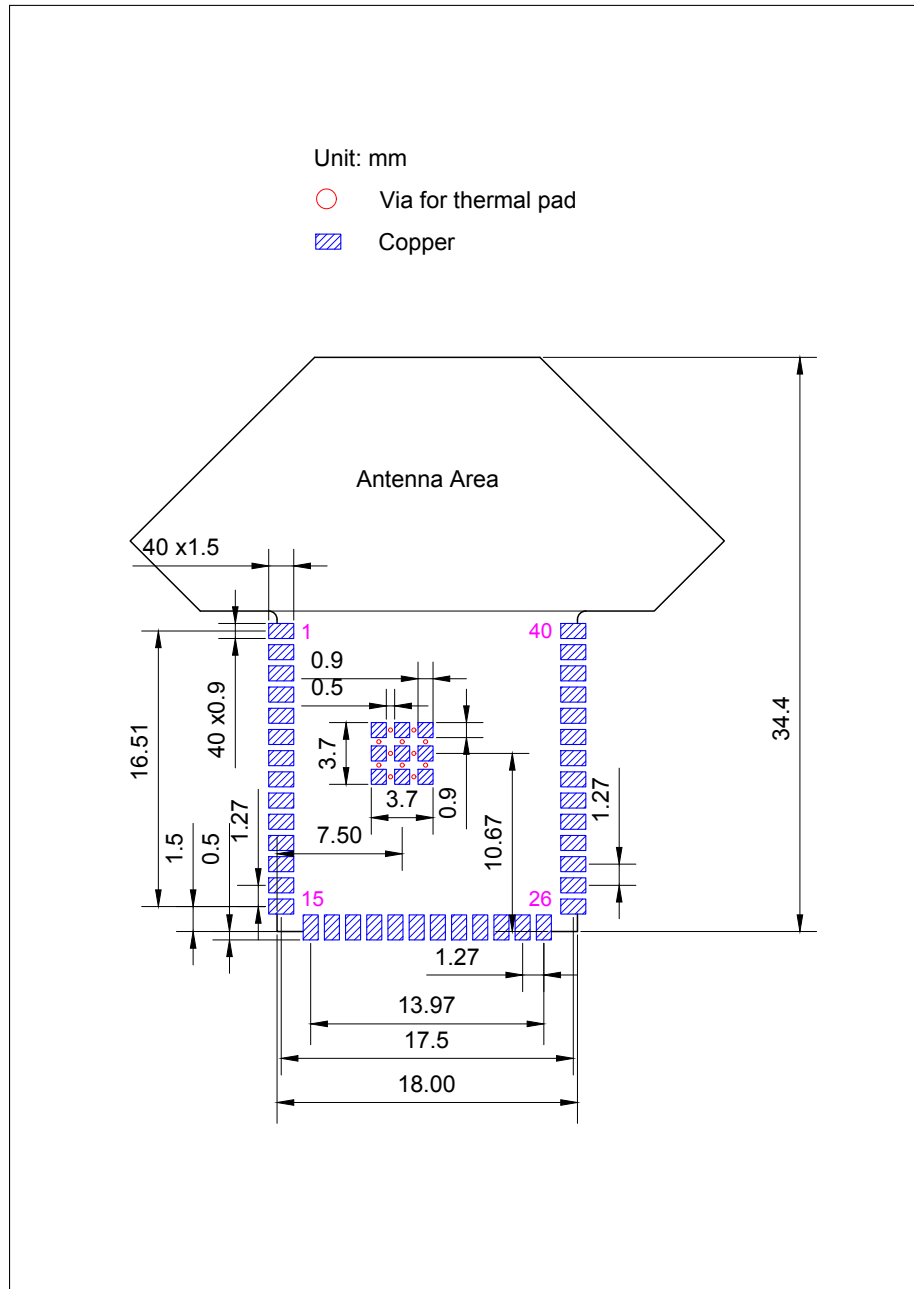

Figure 7: Recommended PCB Land Pattern

8 Product Handling

8.1 Storage Conditions

The products sealed in moisture barrier bags (MBB) should be stored in a non-condensing atmospheric environment of $< 40\text{ }^{\circ}\text{C}$ and 90%RH. The module is rated at the moisture sensitivity level (MSL) of 3.

After unpacking, the module must be soldered within 168 hours with the factory conditions $25 \pm 5\text{ }^{\circ}\text{C}$ and 60 %RH. If the above conditions are not met, the module needs to be baked.

8.2 Electrostatic Discharge (ESD)

- Human body model (HBM): $\pm 2000\text{ V}$
- Charged-device model (CDM): $\pm 500\text{ V}$

8.3 Reflow Profile

Solder the module in a single reflow.

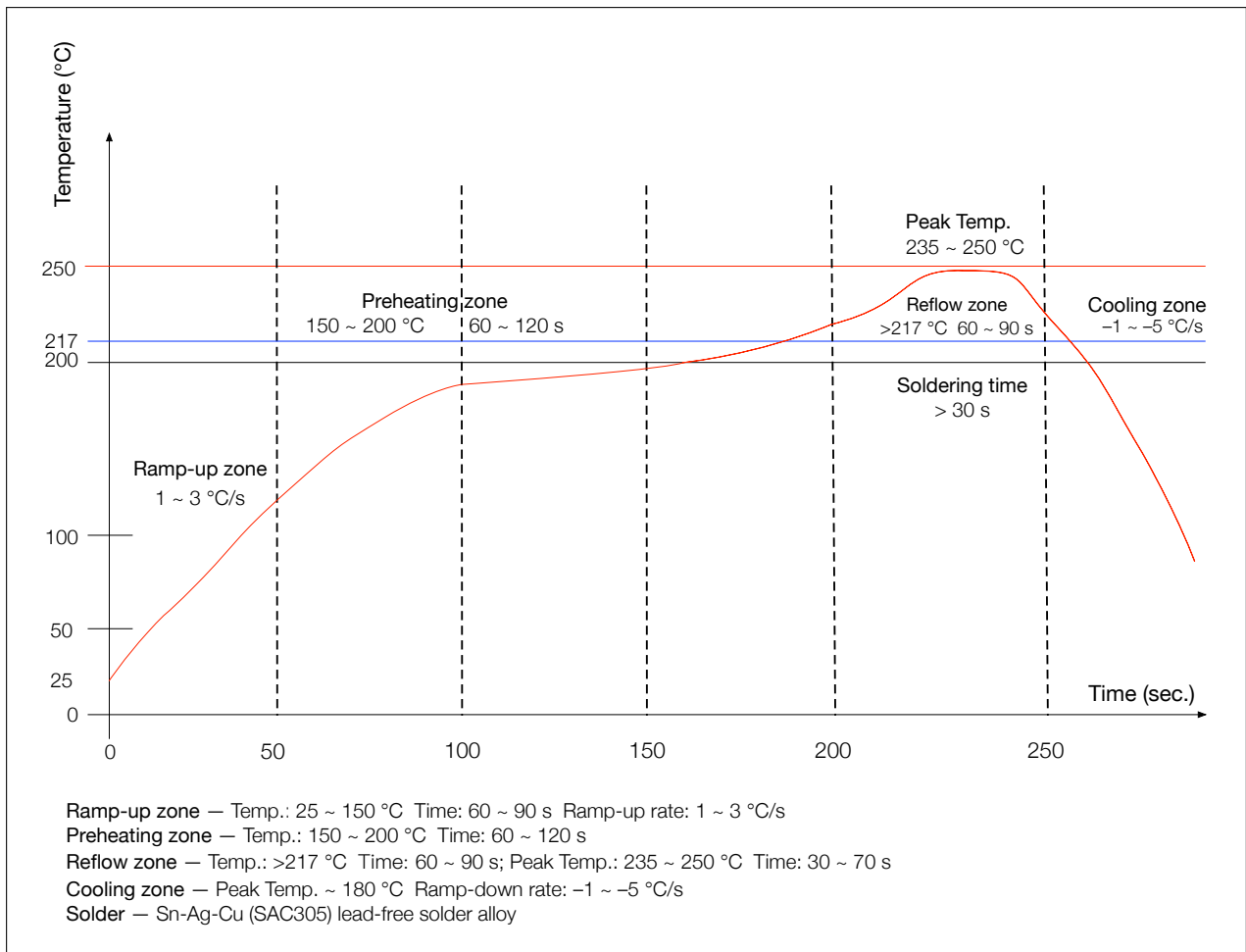

Figure 8: Reflow Profile

8.4 Ultrasonic Vibration

Avoid exposing Espressif modules to vibration from ultrasonic equipment, such as ultrasonic welders or ultrasonic cleaners. This vibration may induce resonance in the in-module crystal and lead to its malfunction or even failure. As a consequence, **the module may stop working or its performance may deteriorate.**

9 Related Documentation and Resources

Related Documentation

- [ESP32 Series Datasheet](#) – Specifications of the ESP32 hardware.
- [ESP32 Technical Reference Manual](#) – Detailed information on how to use the ESP32 memory and peripherals.
- [ESP32 Hardware Design Guidelines](#) – Guidelines on how to integrate the ESP32 into your hardware product.
- [ESP32 ECO and Workarounds for Bugs](#) – Correction of ESP32 design errors.
- *Certificates*
<https://espressif.com/en/support/documents/certificates>
- *ESP32 Product/Process Change Notifications (PCN)*
<https://espressif.com/en/support/documents/pcns>
- *ESP32 Advisories* – Information on security, bugs, compatibility, component reliability.
<https://espressif.com/en/support/documents/advisories>
- *Documentation Updates and Update Notification Subscription*
<https://espressif.com/en/support/download/documents>

Developer Zone

- [ESP-IDF Programming Guide for ESP32](#) – Extensive documentation for the ESP-IDF development framework.
- *ESP-IDF* and other development frameworks on GitHub.
<https://github.com/espressif>
- *ESP32 BBS Forum* – Engineer-to-Engineer (E2E) Community for Espressif products where you can post questions, share knowledge, explore ideas, and help solve problems with fellow engineers.
<https://esp32.com/>
- *The ESP Journal* – Best Practices, Articles, and Notes from Espressif folks.
<https://blog.espressif.com/>
- See the tabs *SDKs and Demos, Apps, Tools, AT Firmware*.
<https://espressif.com/en/support/download/sdks-demos>

Products

- *ESP32 Series SoCs* – Browse through all ESP32 SoCs.
<https://espressif.com/en/products/socs?id=ESP32>
- *ESP32 Series Modules* – Browse through all ESP32-based modules.
<https://espressif.com/en/products/modules?id=ESP32>
- *ESP32 Series DevKits* – Browse through all ESP32-based devkits.
<https://espressif.com/en/products/devkits?id=ESP32>
- *ESP Product Selector* – Find an Espressif hardware product suitable for your needs by comparing or applying filters.
<https://products.espressif.com/#/product-selector?language=en>

Contact Us

- See the tabs *Sales Questions, Technical Enquiries, Circuit Schematic & PCB Design Review, Get Samples* (Online stores), *Become Our Supplier, Comments & Suggestions*.
<https://espressif.com/en/contact-us/sales-questions>

Revision History

Date	Version	Release notes
2023-01-17	v0.6	Major updates: <ul style="list-style-type: none">• Removed contents about hall sensor according to PCN20221202• Added Section 8.4: <i>Ultrasonic Vibration</i> Other updates: <ul style="list-style-type: none">• Added strapping pin timing in Section 3.3: <i>Strapping Pins</i>• Added source files of PCB land pattern in Section 7.2: <i>Recommended PCB Land Pattern</i>
2021-08-19	v0.5	Preliminary release



www.espressif.com

Disclaimer and Copyright Notice

Information in this document, including URL references, is subject to change without notice.

ALL THIRD PARTY'S INFORMATION IN THIS DOCUMENT IS PROVIDED AS IS WITH NO WARRANTIES TO ITS AUTHENTICITY AND ACCURACY.

NO WARRANTY IS PROVIDED TO THIS DOCUMENT FOR ITS MERCHANTABILITY, NON-INFRINGEMENT, FITNESS FOR ANY PARTICULAR PURPOSE, NOR DOES ANY WARRANTY OTHERWISE ARISING OUT OF ANY PROPOSAL, SPECIFICATION OR SAMPLE.

All liability, including liability for infringement of any proprietary rights, relating to use of information in this document is disclaimed. No licenses express or implied, by estoppel or otherwise, to any intellectual property rights are granted herein.

The Wi-Fi Alliance Member logo is a trademark of the Wi-Fi Alliance. The Bluetooth logo is a registered trademark of Bluetooth SIG.

All trade names, trademarks and registered trademarks mentioned in this document are property of their respective owners, and are hereby acknowledged.

Copyright © 2023 Espressif Systems (Shanghai) Co., Ltd. All rights reserved.