

MATERIAL NO.	ENGINEERING NO.	FINISHED LENGTH
1300610256	104006K21M010G	3 FT 3 IN (1.0M)
1300610262	104006K21M080G	26 FT 3 IN (8.0M)
1300610265	104006K21M150G	49 FT 2 IN (15M)

**CABLE LENGTH TOLERANCES**

<.3M [1FT]: +19mm-0 [+ .75in-0]

.3 - .9M [1 - 3FT]: +44.5mm-0 [+1.75in-0]

.9 - 1.8M [3 - 6FT]: +55.6mm-0 [+2.19in-0]

1.8 - 3.7M [6 - 12FT]: +88.9mm-0 [+3.50in-0]

3.7 - 7.3M [12 - 24FT]: +165.1mm-0 [+6.50in-0]

7.3-14.6M [24 - 48FT]: +317.5mm-0 [+12.50in-0]

14.6 - 30.5M [48-100FT]: +622.3mm-0 [+24.50in-0]

OVER 30M [100FT] +2% OF FINISHED LENGTH

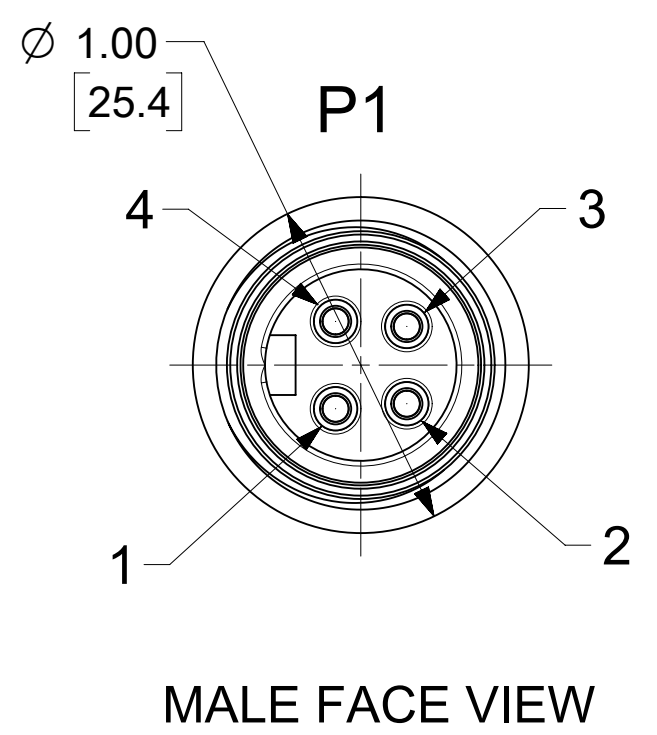
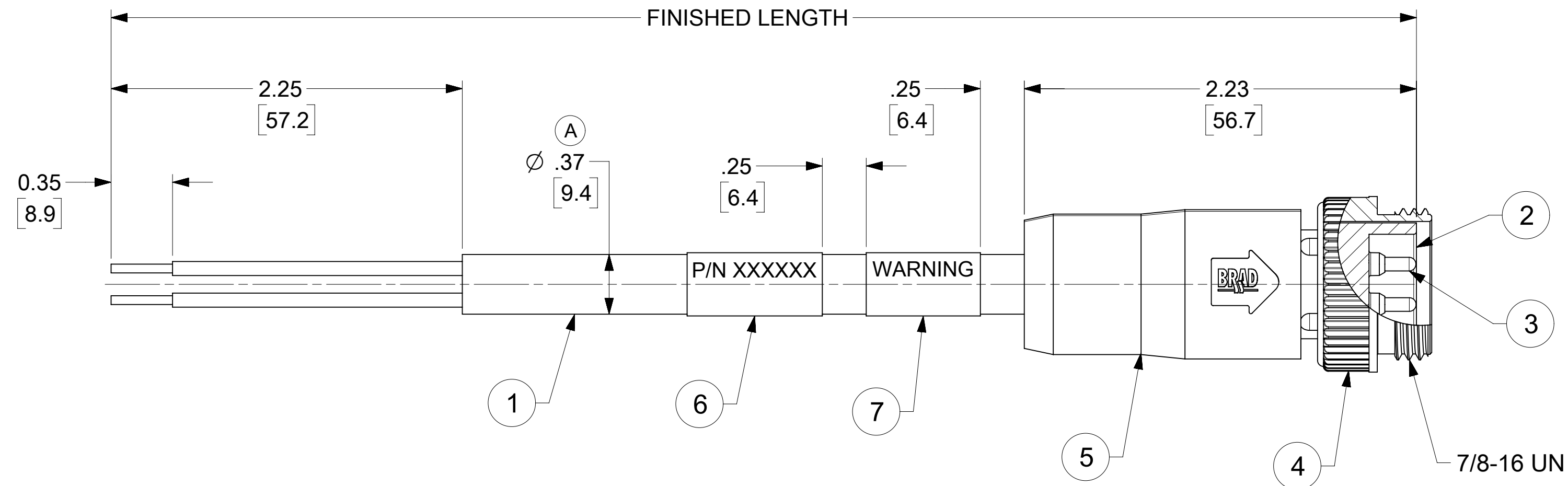
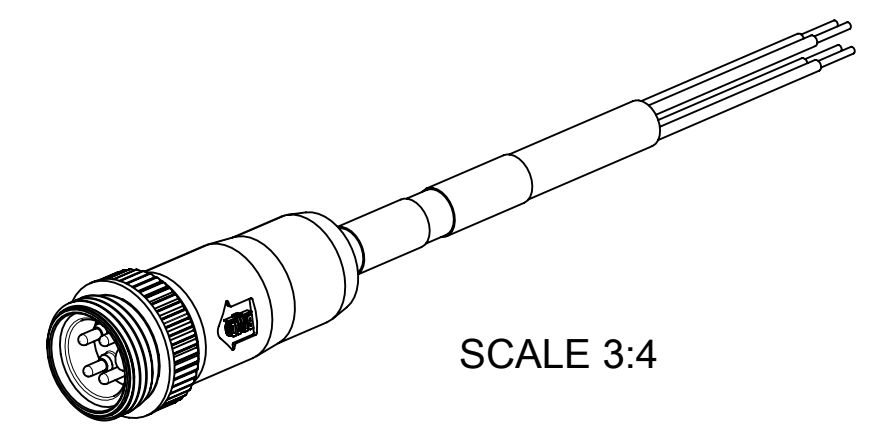

- NOTES:**
- MATERIAL: AS NOTED
  - FINISH: AS NOTED
  - ELECTRICAL:  
VOLTAGE: 483V PER IEC60664  
600V PER UL2237  
CURRENT: 15A
  - TEMP RATING: -20°C TO +90°C
  - PROTECTION: IP67 (WHEN MATED)
  - UL LISTED FILE: E258922
  - ALL DIMS ARE FOR REFERENCE UNLESS TOLERANCED OR NOTED OTHERWISE

**WIRING DIAGRAM**

	P1
BLACK #1	1
BLACK #2	2
BLACK #3	3
GREEN/YELLOW	4

**PART NUMBER LEGEND**

104006K21M010G

OVERMOLD OPTION  
G=BLACK

FINISHED LENGTH  
M001 = 0.1 METER  
M010 = 1.0 METER  
M100 = 10.0 METERS

ITEM	DESCRIPTION	MATERIAL	FINISH
7	WARNING LABEL	VINYL	ORANGE/BLACK
6	WRAP LABEL	VINYL	BLACK/YELLOW
5	OVERMOLD	TPE	BLACK
4	COUPLING NUT	ZINC DIE-CAST	BLACK E-COAT
3	PIN CONTACT	Cu ALLOY	GOLD OVER NICKEL
2	MALE INSERT	TPE	BLACK
1	CABLE, #14-4 TC-ER/MTW	TPE	BLACK

THIS DOC SUPERSEDES SD-130061-039

FUNCTIONAL SYMBOLS	THIS DRAWING CONTAINS INFORMATION THAT IS PROPRIETARY TO MOLEX ELECTRONIC TECHNOLOGIES, LLC AND SHOULD NOT BE USED WITHOUT WRITTEN PERMISSION	CURRENT REV DESC: UPDATED ITEM # 2&5 WERE PVC, MATERIAL & TOLERANCE TABLE & ADDED CABLE DIA.	
FA=0	DIMENSION UNITS: INCH/MM	SCALE: 1.3:1	EC NO: 718076 DRWN: VHANDI 2020/09/21 CHK'D: RSTONE 2022/08/18 APPR: BWOODMAN 2022/08/22
FC=0	GENERAL TOLERANCES (UNLESS SPECIFIED)		
FD=0		MM	INCH
DIVISIONAL SYMBOLS	4 PLACES	±	±
	3 PLACES	±	±
	2 PLACES	±	±
	1 PLACE	±	±
	0 PLACES	±	±
	ANGULAR TOL	±	°
	DRAFT WHERE APPLICABLE MUST REMAIN WITHIN DIMENSIONS	THIRD ANGLE PROJECTION	DRAWING C-SIZE
		SERIES 130061	INITIAL REVISION: DRWN: RSTONE 2016/07/20 APPR: BWOODMAN 2016/08/02

PRODUCT CUSTOMER DRAWING			
DOCUMENT NUMBER	DOC TYPE	DOC PART	REVISION
1300610256	PSD	000	A
MATERIAL NUMBER	CUSTOMER	SHEET NUMBER	
SEE TABLE	GENERAL MARKET	1 OF 1	