

Application:

- Intel LGA775 Conroe-L Celeron CPU
- E1000/400 sequence

Thermal & Mechanical Spec.:

- Thermal performance for 35W CPU
- HSK Assembly Weight: 205 g (ref.)
- Clipping Force: 20 Kgf (ref.)

Component Specification:

- Heat Sink
 - Type: Extruded HSK
 - Material: Aluminum A6063 or Equivalent.
 - Dimension: 90*90*19.05 mm
- Thermal interface material 
 - Material: Dow Corning TC-5630 or Equivalent.
- Fan *(90x90x25 mm with single speed)*
 - Rated Voltage: 12 V
 - Life Time: Superflo bearing 50000 hrs
 - Connector:
 - Lead wire: UL 1430 AWG#26
 - pin 1: black wire-----(-)
 - pin 2: yellow wire-----(+)
 - pin 3: green wire----- (F00)
 - Housing: Molex 2695-03 22-01-3037 or equivalent
 - Terminal: Molex 2759T 08-50-0113 or equivalent

Pictures

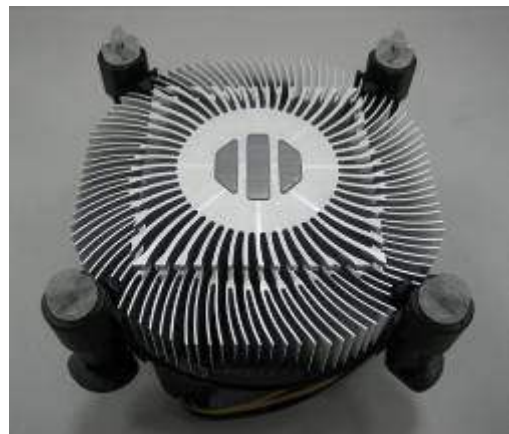

* All readings are typical values at rated voltage.
 * Specifications are subject to change without notice



APPROVAL SHEET

Customer Name .:

Model Name.: COOLER

Delta Part No.: FHS-A9025S17

Customer Part No.:

Spec Issue Date .: 01/05/2016

Spec Revision : 03

PLEASE SEND ONE COPY OF THIS SPECIFICATION BACK AFTER YOU
SIGNED APPROVAL FOR PRODUCTION PRE-ARRANGMENT.

Approved By: _____

Date: _____

Approval	Check	Designer
<i>Alex-Hsia</i>	<i>Charles Chen</i>	Skyler-Huang



Delta Electronics Corp.

REV.	Description	Drawn	Checked	Approved	Issue Date
00	ISSUE SPEC	Skyler-Huang12/29'09	Charles.Chen12/29'09	Alex-Hsia 12/29'09	
01	1. Modify the Package spec	Skyler-Huang08/09'12	Charles.Chen08/09'12	Alex-Hsia 08/09'12	
02	1. Modify the Package spec	Skyler-Huang06/10'13	Charles.Chen06/10'13	Alex-Hsia 06/10'13	
03	1.Change the TIM to TC-5630	Skyler-Huang1/05'16	Charles.Chen1/05'16	Alex-Hsia 1/05'16	
Description: SAMPLE REVISION CODE LIST					
Part No.					REV
DELTA MODEL : FHS-A9025S17			TOTAL 23 PAGE		03



Delta Electronics Corp.

CONTENTS

Item	Element Description	Page	Note
1	Specification	5	
2	Print	6	
3	Packing Plan	12	
4	Fan	15	



Delta Electronics Corp.

2. PRINT

Assembly Drawing

Parts Drawing

DRAWING:

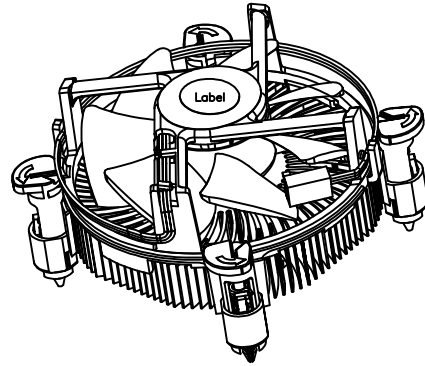
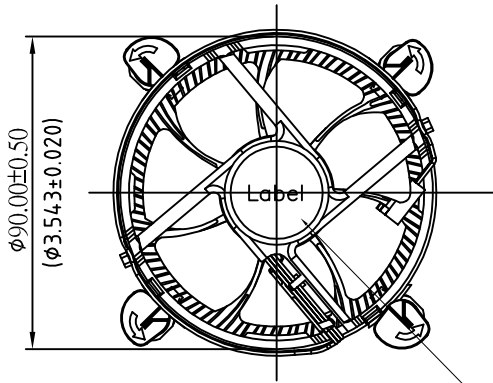

FAN LABEL P/N:3266708200

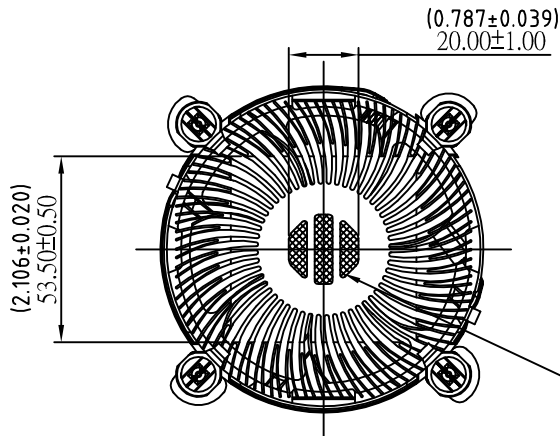
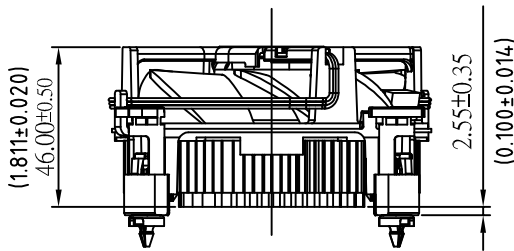



Dow Corning TC-5630 P/N:4021107300

STENCIL THICKNESS=0.20(TYP.) 0.22(MAX.)

TIM WEIGHT ON HSK MUST BE 112.5mg+/-30mg

UNIT: $\frac{\text{mm}}{\text{(INCH)}}$

*NOTE: PLEASE ATTENTION FAN LABEL ORIENTATION.

 台達電子工業股份有限公司 DELTA ELECTRONICS, INC.	DELTA MODEL: FHS-A9025S17	Drawn: Skyler Huang
	CUSTOMER NAME: ----- CUSTOMER P/N: -----	
THESE DRAWINGS AND SPECIFICATIONS ARE THE PROPERTY OF DELTA ELECTRONICS, INC. AND SHALL NOT BE REPRODUCED OR USED AS THE BASIS FOR THE MANUFACTURE OR SELL OF APPARATUSES OR DEVICES WITHOUT PERMISSION.	Description: PRODUCTION SPEC. (PHYSICAL DIMENSION)	
DIMENSIONAL TOLERANCES () () () HOLES : ± 0.05 ANGLES : $\pm 0.5^\circ$ <math><30 \pm 0.25</math> $X \pm 0.3$ $UP \sim 100 \pm 0.2$ $250 \sim 300 \pm 0.4$ $UP \sim 800 \pm 1.5$ $>30 \sim 100 \pm 0.35$ $100 \sim 150 \pm 0.25$ $300 \sim 350 \pm 0.45$ $600 \sim 900 \pm 2.4$ $>100 \sim 300 \pm 0.5$ $X.X \pm 0.2$ $150 \sim 200 \pm 0.3$ $350 \sim 400 \pm 0.5$ $900 \sim \text{OVER} \pm 3.1$ ABOVE 300 ± 0.6 $X.XX \pm 0.1$ $200 \sim 250 \pm 0.35$	 Part No. FHS-A9025S17-PD	REV. 03
SCALE --- UNIT mm USED ON COOLER	A4 SIZE SHEET 1 OF 2 ISSUE DATE:	



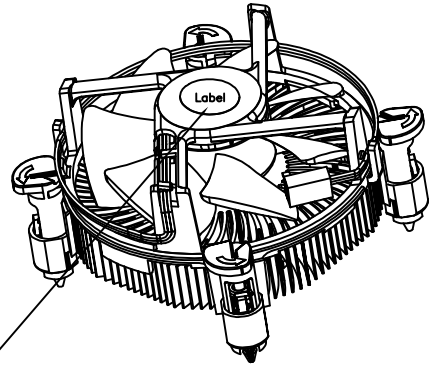

DATECODE POSITION
TYPE: WHITE INK



DATECODE POSITION

NOTE:

1. DATECODE ON FAN LABEL
2. PLEASE REFER TO CP10S-00345 WHILE PRINTING DATECODE.

 台達電子工業股份有限公司 DELTA ELECTRONICS, INC.	DELTA MODEL: FHS-A9025S17	Drawn: Skyler Huang	
	CUSTOMER NAME: ----- CUSTOMER P/N: -----		
THESE DRAWINGS AND SPECIFICATIONS ARE THE PROPERTY OF DELTA ELECTRONICS, INC. AND SHALL NOT BE REPRODUCED OR USED AS THE BASIS FOR THE MANUFACTURE OR SELL OF APPARATUSES OR DEVICES WITHOUT PERMISSION.	Description: PRODUCTION SPEC. (PHYSICAL DIMENSION)		
DIMENSIONAL TOLERANCES () () () HOLES : ±0.05 ANGLES : ±0.5° () () () () () <30 :±0.25 DECIMALS UP~100 :±0.2 250~300 :±0.4 UP~800 :±1.5 >30~100 :±0.35 X :±0.3 100~150 :±0.25 300~350 :±0.45 800~900 :±2.4 >100~300 :±0.5 XX :±0.2 150~200 :±0.3 350~400 :±0.5 900~OVER :±3.1 ABOVE 300 :±0.6 XXX :±0.1 200~250 :±0.35	 THIRD ANGLE PROJECTION	Part No. FHS-A9025S17-PD	REV. 03
SCALE --- UNIT mm USED ON COOLER	A4 SIZE	SHEET 2 OF 2 ISSUE DATE:	

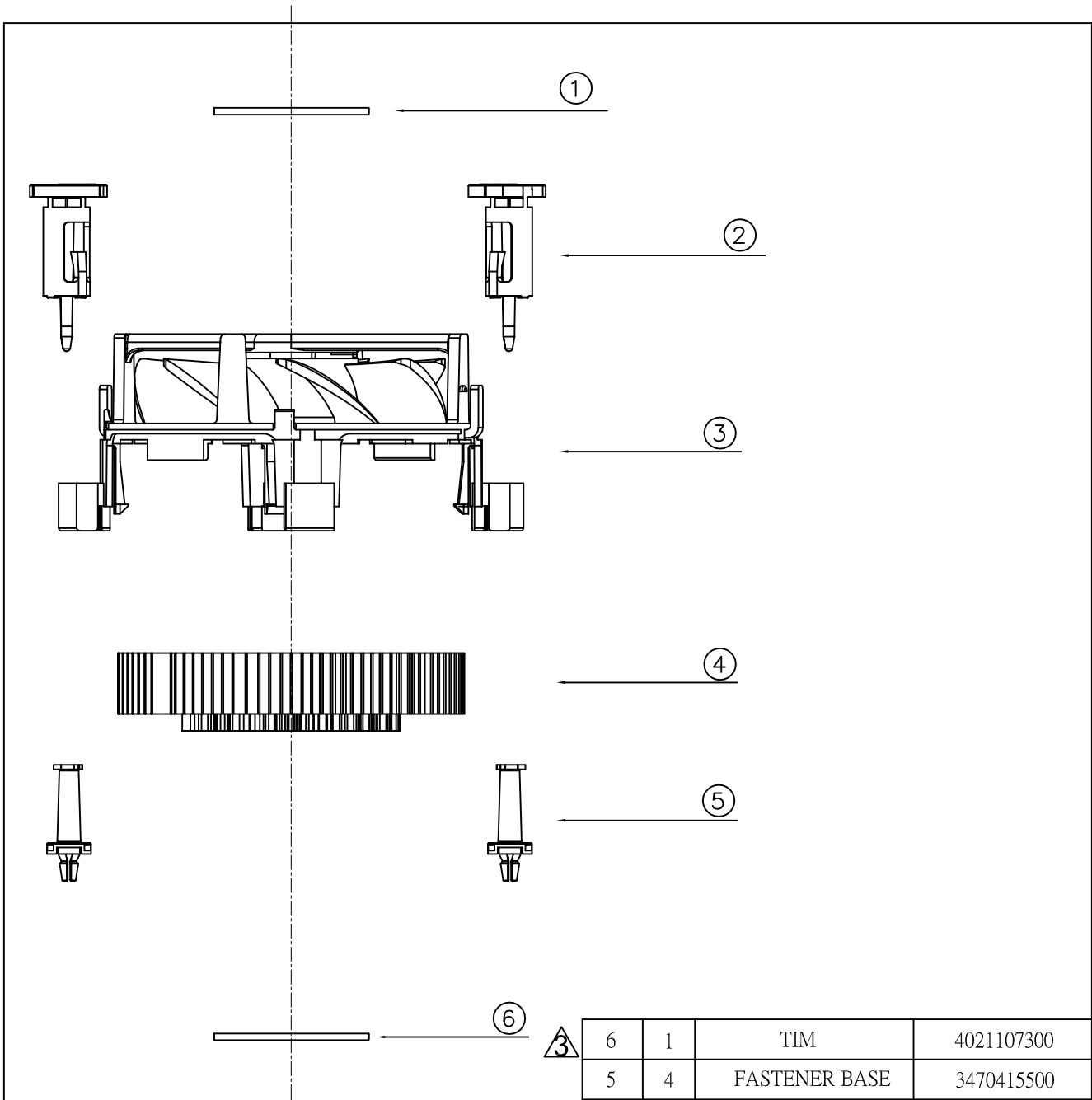

6	1	TIM	4021107300
5	4	FASTENER BASE	3470415500
4	1	HEATSINK	3346208500
3	1	FAN	3622916811
2	4	FASTENER CAP	3470415400
1	1	FAN LABEL	3266708200
ITEM	QTY	DESCRIPTION	PART NUMBER



台達電子工業股份有限公司
DELTA ELECTRONICS, INC.

DELTA MODEL:
FHS-A9025S17

Drawn:
Skyler Huang

THESE DRAWINGS AND SPECIFICATIONS ARE THE PROPERTY OF DELTA ELECTRONICS, INC. AND SHALL NOT BE REPRODUCED OR USED AS THE BASIS FOR THE MANUFACTURE OR SELL OF APPARATUSES OR DEVICES WITHOUT PERMISSION.

CUSTOMER NAME: -----
CUSTOMER P/N: -----

DIMENSIONAL TOLERANCES		HOLES : ±0.05		ANGLES : ±0.5°	
()	()	()	()	()	()
<30	±0.25	DECIMALS	UP~100 ±0.2	250~300 ±0.4	UP~800 ±1.5
>30~100	±0.35	X	±0.3	100~150 ±0.25	300~350 ±0.45
>100~300	±0.5	XX	±0.2	150~200 ±0.3	350~400 ±0.5
ABOVE 300	±0.6	XXX	±0.1	200~250 ±0.35	900~OVER ±3.1



Description: PRODUCTION SPEC.
(ASSEMBLY ORDER)

A4
SIZE

Part No. FHS-A9025S17-AS

REV.
03

SCALE --- UNIT mm USED ON COOLER

SHEET 1 OF 1 ISSUE DATE:

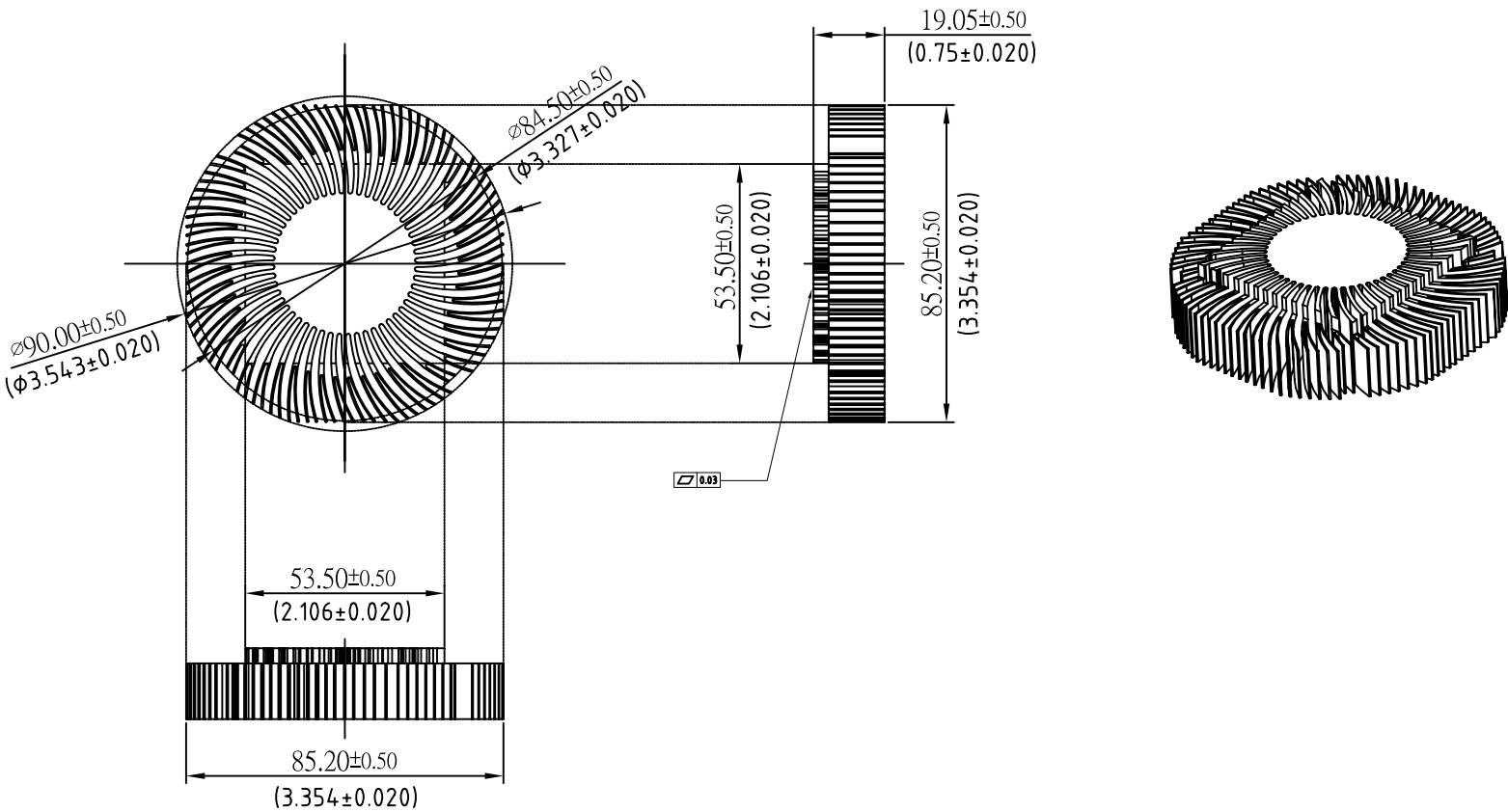

NOTE

1. MATERIAL : AL A6063 T5.
2. UNLESS OTHERWISE SPECIFIED - ALL ROUNDS & FILLETS R0.1, AND BURRS & SHARP EDGES TO BE WITHIN 0.1.
3. APPEARANCE OF SURFACES TO BE UNIFORM, AND FREE OF DUST, METAL FLAKES, ADHESIVES, OIL, BLEMISHES AND SCRATCHES.

台達電子工業股份有限公司 DELTA ELECTRONICS, INC.					Drawn: Skyler Huang	
THESE DRAWINGS AND SPECIFICATIONS ARE THE PROPERTY OF DELTA ELECTRONICS, INC. AND SHALL NOT BE REPRODUCED OR USED AS THE BASIS FOR THE MANUFACTURE OR SELL OF APPARATUS OR DEVICES WITHOUT PERMISSION.					DESCRIPTION: HEATSINK	
DIMENSIONAL TOLERANCES () () () () () <30 :±0.25 DECIMALS UP~100 :±0.2 250~300 :±0.4 UP~600 :±1.5 >30~100 :±0.35 X :±0.5 100~150 :±0.25 300~350 :±0.45 600~900 :±2.4 >100~300 :±0.5 XX :±0.2 150~200 :±0.3 350~400 :±0.5 900~OVER :±3.1 ABOVE 300 :±0.6 XXX :±0.1 200~250 :±0.35					PART NO.: 3346208500	
SCALE 1/1 UNIT mm USED ON COOLER					SHEET 1 OF 1	

1

2

3

4

A

A

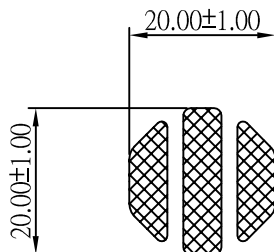



B

B

- NOTES: 1. THICKNESS: 0.20mm
 2. VENDOR P/N: DOW CORNING TC-5630
 3. COLOR: GRAY.
 4. THERMAL CONDUCTIVITY: 4.5 W/m-°C
 5. THERMAL CONTACT RESISTANCE: 0.06 °C-cm²/W @40psi
 6. GROSS WEIGHT: 112.5±30 mg
 7. VENDOR : DOW CORNING
 8. MUST MEET DELTA'S SPEC : 10000-0162

C

C

 台達電子工業股份有限公司 DELTA ELECTRONICS, INC.		Drawn: Skyler Huang	
THESE DRAWINGS AND SPECIFICATIONS ARE THE PROPERTY OF DELTA ELECTRONICS, INC. AND SHALL NOT BE REPRODUCED OR USED AS THE BASIS FOR THE MANUFACTURE OR SELL OF APPARATUS OR DEVICES WITHOUT PERMISSION.		 DESCRIPTION: THERMAL INTERFACE	
DIMENSIONAL TOLERANCES () : ±0.25 (✓) : ±0.5 () : ±0.5 <30 : ±0.25 DECIMALS UP-100 : ±0.2 250-300 : ±0.4 UP-600 : ±1.6 >30-100 : ±0.25 X : ±0.5 100-150 : ±0.25 300-350 : ±0.45 600-900 : ±2.4 >100-300 : ±0.5 XX : ±0.8 150-200 : ±0.5 350-400 : ±0.5 900-OVER : ±3.1 ABOVE 300 : ±0.6 XXX : ±0.1 300-350 : ±0.35		PART NO.: 4021107300 REV. 03	
SCALE	1/1	UNIT	mm
USED ON	COOLER	SHEET 1 OF 1	

1

2

3



4



Delta Electronics Corp.

3. PACKING PLAN

Packing Specification

CARTON ILLUSTRATE	SIZE	524(L)*225(w)*475(H)(mm) 	PACKING QUANTITY	6LAYERS/CARTON 
	MATERIAL	3 LAYERS"AB" FLUTE	CARTON WEIGHT	0.62 kg (REF.)

CARTON OUTSIDE ILLUSTRATE

FRONT

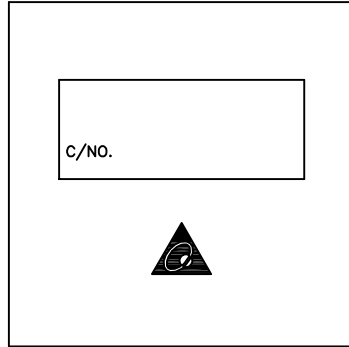

BACK

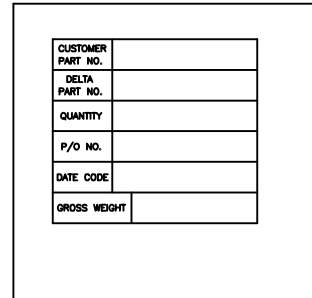

(ONE LABEL PER CARTON)

PET TRAY PACKING ILLUSTRATE	SIZE	94(L)*94(w)*30(H)(mm)	PACKING QUANTITY	1PCS/PET TRAY
	MATERIAL	PET TRAY		
	MATERIAL WEIGHT	6g (REF.)		

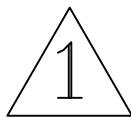

CARTON

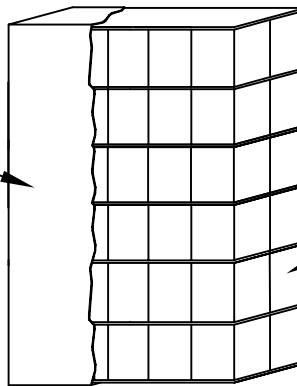

PAPER PAD(7X)

BOX(60X)



台達電子工業股份有限公司
DELTA ELECTRONICS, INC.

DELTA MODEL:
FHS-A9025S17

Drawn:
Skyler Huang

THESE DRAWINGS AND SPECIFICATIONS ARE THE PROPERTY OF DELTA ELECTRONICS, INC. AND SHALL NOT BE REPRODUCED OR USED AS THE BASIS FOR THE MANUFACTURE OR SELL OF APPARATUS OR DEVICES WITHOUT PERMISSION.

CUSTOMER NAME: -----
CUSTOMER P/N: -----

DIMENSIONAL TOLERANCES		HOLES : ±0.05		ANGLES : ±0.5°	
()	()	()	()	()	()
<30	±0.25	DECIMALS	UP~100 ±0.2	250~300 ±0.4	UP~800 ±1.5
>30~100	±0.35	X	±0.3	100~150 ±0.25	300~350 ±0.45
>100~300	±0.5	XX	±0.2	150~200 ±0.3	350~400 ±0.5
ABOVE 300	±0.6	XXX	±0.1	200~250 ±0.35	900~OVER ±3.1



Description: PRODUCTION SPEC.
(PACKING ASSMEBLY)

A4
SIZE

Part No.
FHS-A9025S17-PA

REV.

SCALE --- UNIT mm USED ON COOLER

SHEET 1 OF 2 ISSUE DATE:

PART NO.	FHS-A9025S17													
BASIC DATA	QUANTITY/CARTON	60PCS (6 LAYERS/CARTON, 10PCS/LAYER) $\triangle 1$												
	PRODUCTION NET WEIGHT	12.3kg (REF.) $\triangle 1$												
	PRODUCTION GROSS WEIGHT	16.1kg (REF.) $\triangle 1$												
20(ft)CONTAINER ILLUSTRATE	SIZE	5.889(L)*2.352(w)*2.386(H)m		PACKING QUANTITY	20PALLET/CONTAINER									
	CONTAINER	STEEL												
CONTAINER FORM				$\triangle 2$	<table border="1"> <tr><td>PALLET</td><td>PALLET</td></tr> <tr><td>PALLET</td><td>PALLET</td></tr> </table> <p>FRONT VIEW</p>	PALLET	PALLET	PALLET	PALLET					
PALLET	PALLET													
PALLET	PALLET													
CONTAINER LOADING MATHOD														
<table border="1"> <tr><td>PALLET</td><td>PALLET</td><td>PALLET</td><td>PALLET</td><td>PALLET</td></tr> <tr><td>PALLET</td><td>PALLET</td><td>PALLET</td><td>PALLET</td><td>PALLET</td></tr> </table> <p>TOP VIEW</p>				PALLET	PALLET	PALLET	PALLET	PALLET	PALLET	PALLET	PALLET	PALLET	PALLET	
PALLET	PALLET	PALLET	PALLET	PALLET										
PALLET	PALLET	PALLET	PALLET	PALLET										

PALLET LOADING ILLUSTRATE	SIZE	117(L)*107(w)*13(H)cm	PACKING QUANTITY	20 CARTONS/PALLET
	PALLET	WOOD		

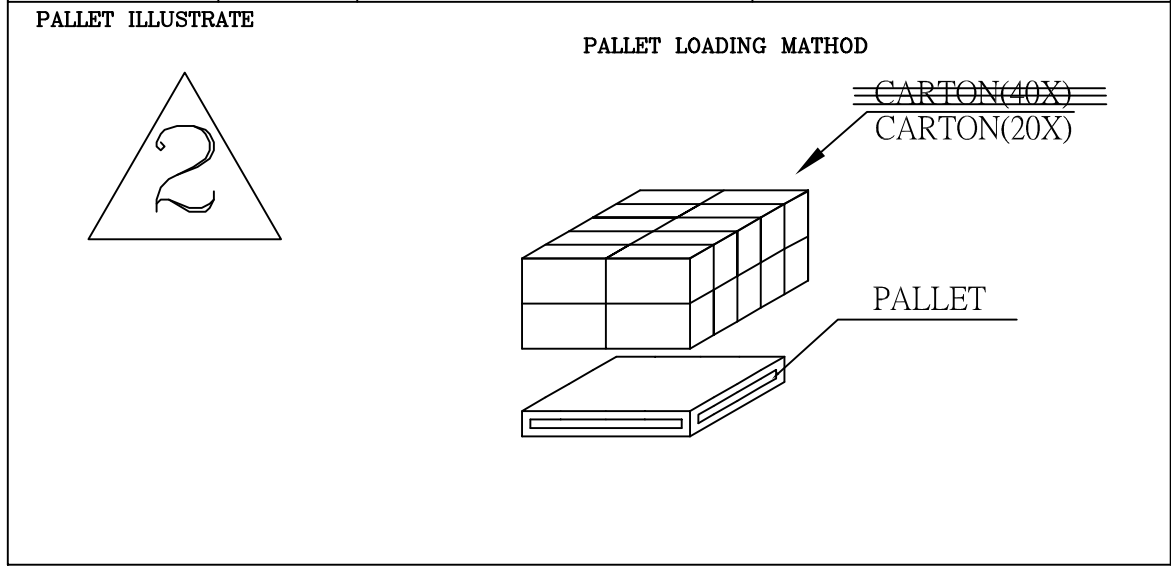

台達電子工業股份有限公司 DELTA ELECTRONICS, INC.	DELTA MODEL:	FHS-A9025S17	Drawn:	Skyler Huang
	THESE DRAWINGS AND SPECIFICATIONS ARE THE PROPERTY OF DELTA ELECTRONICS, INC. AND SHALL NOT BE REPRODUCED OR USED AS THE BASIS FOR THE MANUFACTURE OR SELL OF APPARATUSES OR DEVICES WITHOUT PERMISSION.	CUSTOMER NAME:	-----	CUSTOMER P/N:
DIMENSIONAL TOLERANCES () () () HOLES : ± 0.05 ANGLES : $\pm 0.5^\circ$ <30 ± 0.25 DECIMALS UP~100 ± 0.2 250~300 ± 0.4 UP~800 ± 1.5 >30~100 ± 0.35 X ± 0.3 100~150 ± 0.25 300~350 ± 0.45 600~900 ± 2.4 >100~300 ± 0.5 XX ± 0.2 150~200 ± 0.3 350~400 ± 0.5 900~OVER ± 3.1 ABOVE 300 ± 0.6 XXX ± 0.1 200~250 ± 0.35	Description: PRODUCTION SPEC. (PACKING ASSMEBLY)	Part No. FHS-A9025S17-PA	REV. ---	
SCALE --- UNIT mm USED ON COOLER	A4 SIZE	SHEET 2 OF 2	ISSUE DATE:	



Delta Electronics Corp.

4. FAN

Fan Specification



SPECIFICATION FOR APPROVAL

Customer TMP BU

Description DC FAN

Part No. _____ REV. _____

Delta Model No. AUB0912M-8J29 REV. 00

Sample Issue No. _____

Sample Issue Date SEP.09.2008

PLEASE SEND ONE COPY OF THIS SPECIFICATION BACK AFTER YOU SIGNED APPROVAL FOR PRODUCTION PRE-ARRANGMENT. APPROVED BY: _____ DATE : _____

DELTA ELECTRONICS, INC.
TAOYUAN PLANT
252, SHANG YING ROAD, KUEI SAN INDUSTRIAL ZONE
TAOYUAN SHIEN, TAIWAN, R.O.C.
TEL:886-(0)3-3591968
FAX:886-(0)3-3591991

DELTA ELECTRONICS, INC.
 252, SHANG YING ROAD, KUEI SAN
 TAOYUAN HSIEN 333, TAIWAN, R. O. C.

TEL : 886-(0)3-3591968
 FAX : 886-(0)3-3591991

SPECIFICATION FOR APPROVAL

Customer: TMP BU

 Description: DC FAN

 Customer P/N: REV:

 Delta Model NO.: AUB0912M-8J29

 Sample Rev: 00 Issue NO:

 Sample Issue Date: SEP.09.2008 Quantity:

1. SCOPE:

THIS SPECIFICATION DEFINES THE ELECTRICAL AND MECHANICAL CHARACTERISTICS OF THE DC BRUSHLESS AXIAL FLOW FAN. THE FAN MOTOR IS WITH SINGLE PHASES AND FOUR POLES.

2. CHARACTERS:

ITEM	DESCRIPTION
RATED VOLTAGE	12.0 VDC
OPERATION VOLTAGE	10.8 - 13.2 VDC
START UP CURRENT	MAX. 1.2 A
INPUT CURRENT	0.09 (MAX. 0.20) A
INPUT POWER	1.08 (MAX. 2.40) W
SPEED (FAN ONLY)	2250±10% R.P.M.
SPEED (FAN ON SINK)	2200±10% R.P.M.
MAX. AIR FLOW (FAN ONLY) (AT ZERO STATIC PRESSURE)	0.619 (MIN. 0.557) M ³ /MIN. 21.86 (MIN. 19.67) CFM
MAX. AIR PRESSURE (FAN ONLY) (AT ZERO AIRFLOW)	1.86 (MIN. 1.51) mmH ₂ O 0.073 (MIN. 0.059) inchH ₂ O
ACOUSTICAL NOISE(ON SINK AVG.)	27.0 (MAX. 31.0) dB-A
INSULATION TYPE	UL: CLASS A

(continued)

PART NO:

DELTA MODEL:

AUB0912M-8J29

INSULATION STRENGTH	10 MEG OHM MIN. AT 500 VDC (BETWEEN FRAME AND (+) TERMINAL)
DIELECTRIC STRENGTH	5 mA MAX. AT 500 VAC 60 Hz ONE MINUTE, (BETWEEN FRAME AND (+) TERMINAL)
EXTERNAL COVER	OPEN TYPE
LIFE EXPECTANCE	50,000 HOURS CONTINUOUS OPERATION AT 40 °C WITH 15 ~ 65 %RH.
ROTATION	CLOCKWISE VIEW FROM NAME PLATE SIDE
OVER CURRENT SHUT DOWN	THE CURRENT WILL SHUT DOWN WHEN LOCKING ROTOR
LEAD WIRE	UL 1430 -F- AWG #26 BLACK WIRE:NEGATIVE(-) YELLOW WIRE:POSITIVE(+) GREEN WIRE:TACHOMETER OUTPUT (F00)

- NOTES: 1. ALL READINGS ARE MEASURED AFTER STABLY WARMING UP THROUGH 10 MINUTES.
2. THE VALUES WRITTEN IN PARENS , (), ARE LIMITED SPEC.
3. ACOUSTICAL NOISE MEASURING CONDITION:

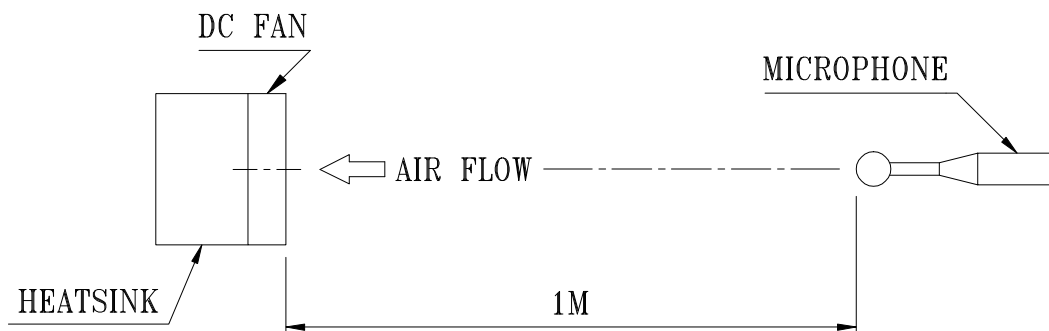

NOISE IS MEASURED AT RATED VOLTAGE IN FREE AIR IN ANECHOIC CHAMBER WITH B & K SOUND LEVEL METER WITH MICROPHONE AT A DISTANCE OF ONE METER FROM THE FAN INTAKE.

PART NO:

DELTA MODEL: AUB0912M-8J29

3. MECHANICAL:

- 3-1. DIMENSIONS ----- SEE DIMENSIONS DRAWING
- 3-2. FRAME ----- PLASTIC UL: 94V-0
- 3-3. IMPELLER ----- PLASTIC UL: 94V-0
- 3-4. BEARING SYSTEM ----- SUPERFLO BEARING
- 3-5. WEIGHT ----- 82 GRAMS

4. ENVIRONMENTAL:

- 4-1. OPERATING TEMPERATURE ----- -10 TO +60 DEGREE C
- 4-2. STORAGE TEMPERATURE ----- -40 TO +70 DEGREE C
- 4-3. OPERATING HUMIDITY ----- 5 TO 95 % RH
- 4-4. STORAGE HUMIDITY ----- 5 TO 95 % RH

5. PROTECTION:

- 5-1. LOCKED ROTOR PROTECTION
IMPEDANCE OF MOTOR WINDING PROTECTS MOTOR FROM FIRE IN 96 HOURS OF LOCKED ROTOR CONDITION AT THE RATED VOLTAGE.
- 5-2. POLARITY PROTECTION
BE CAPABLE OF WITHSTANDING IF REVERSE CONNECTION FOR POSITIVE AND NEGATIVE LEADS.

6. RE OZONE DEPLETING SUBSTANCES:

- 6-1. NO CONTAINING PBBs, PBBOs, CFCs, PBBEs, PBDPEs AND HCFCs.

7. PRODUCTION LOCATION

- 7-1. PRODUCTS WILL BE PRODUCED IN CHINA OR THAILAND OR TAIWAN.

PART NO:

DELTA MODEL: AUB0912M-8J29

8. P & Q CURVE:

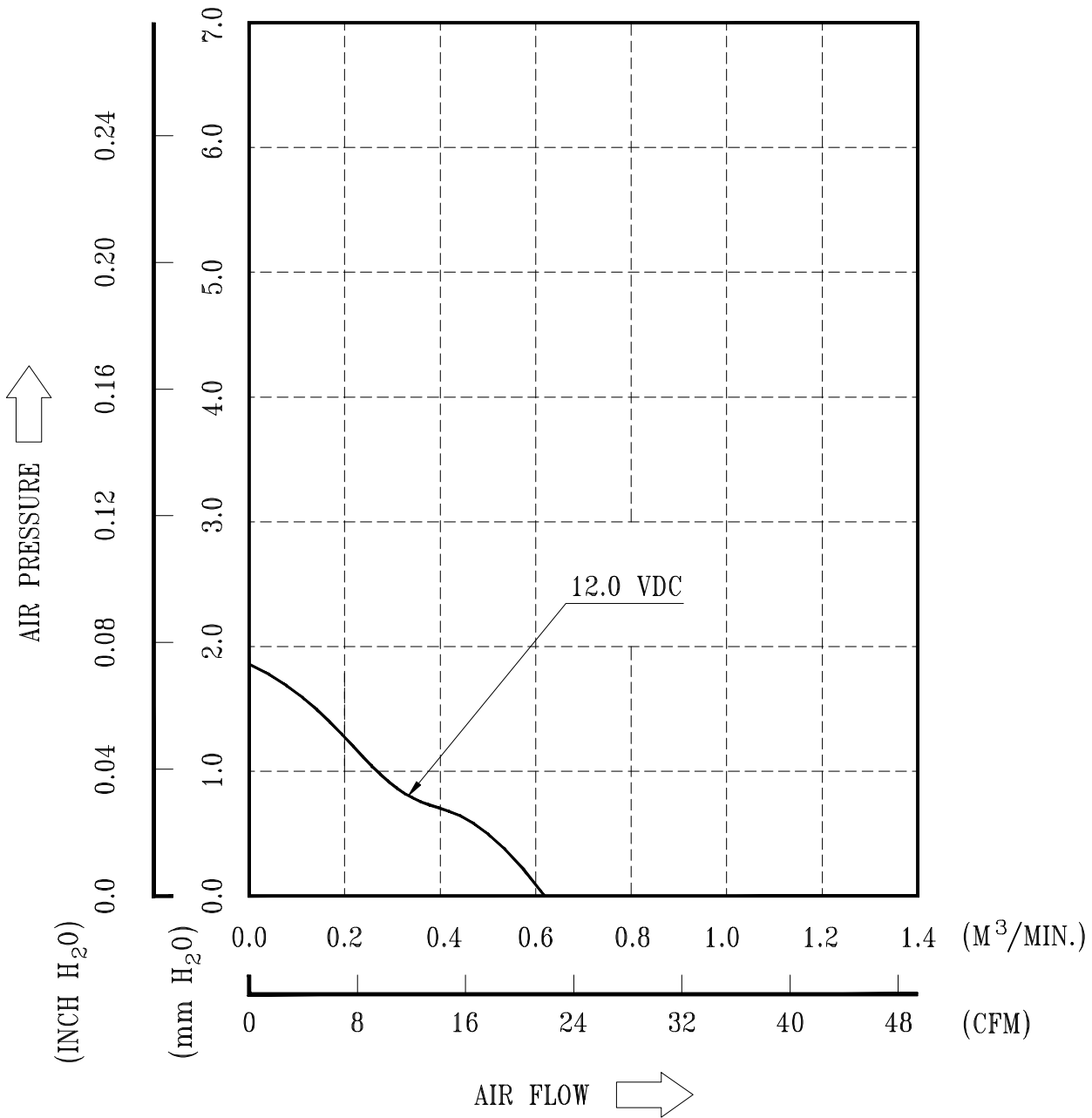

* TEST CONDITION: INPUT VOLTAGE ----- OPERATION VOLTAGE
TEMPERATURE ----- ROOM TEMPERATURE
HUMIDITY ----- 65%RH

PART NO:

DELTA MODEL: AUB0912M-8J29

9. DIMENSION DRAWING:

LABEL:

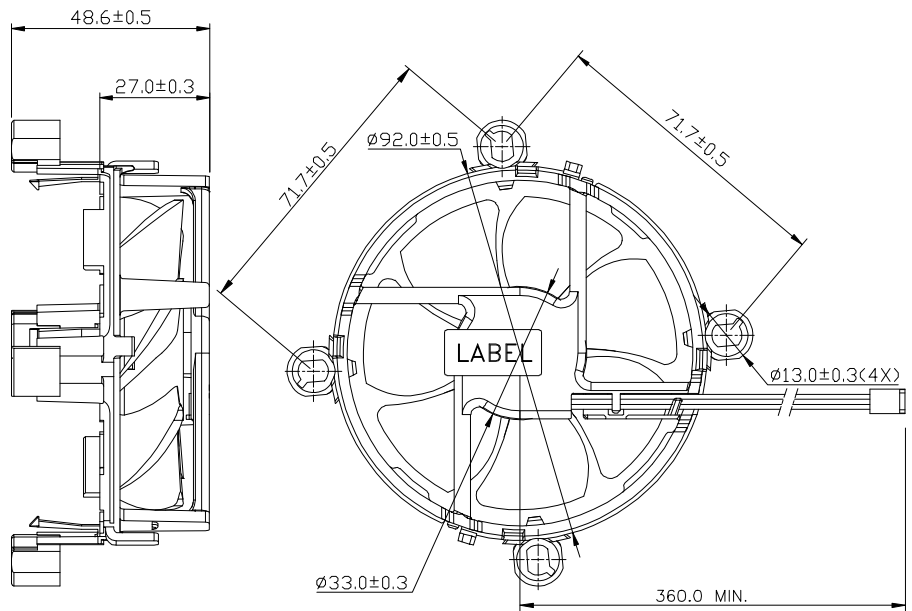

UNIT: MM

NOTE :

1. LEAD WIRE: UL 1430 -F- AWG #26
PIN 1 : BLACK WIRE: NEGATIVE(-)
PIN 2 : YELLOW WIRE: POSITIVE(+)
PIN 3 : GREEN WIRE: TACHOMETER OUTPUT (F00)
2. HOUSING : MOLEX 2695-03 22-01-3037 OR EQUIVALENT
3. TERMINAL : MOLEX 2759T 08-50-0113 OR EQUIVALENT
4. THIS PRODUCT IS RoHS COMPLIANT

PART NO:

DELTA MODEL: AUB0912M-8J29

10. FREQUENCY GENERATOR (FG) SIGNAL:

1. OUTPUT CIRCUIT - OPEN COLLECTOR MODE:

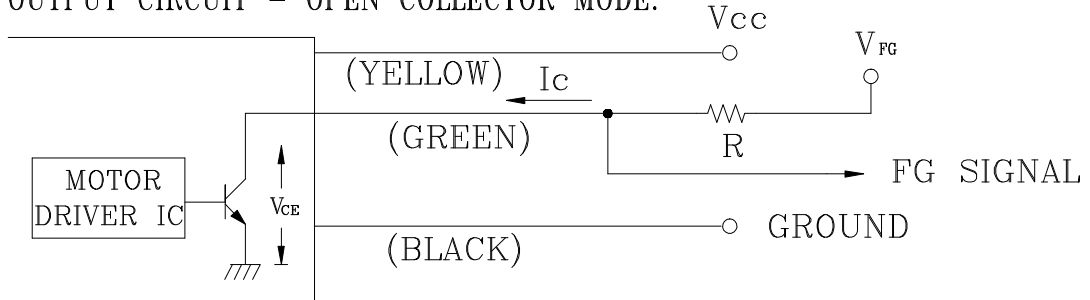

CAUTION: THE FG SIGNAL LEAD WIRE MUST BE KEPT AWAY FROM
" + " LEAD WIRE & " - " LEAD WIRE.

2. SPECIFICATION:

$$V_{CE(sat)} = 0.5V$$

$$V_{FG} = 5.0V \text{ TYP. } (V_{CC} \text{ MAX.})$$

$$I_c = 10mA \text{ MAX.}$$

$$R \geq V_{FG} / I_c$$

3. FREQUENCY GENERATOR WAVEFORM:

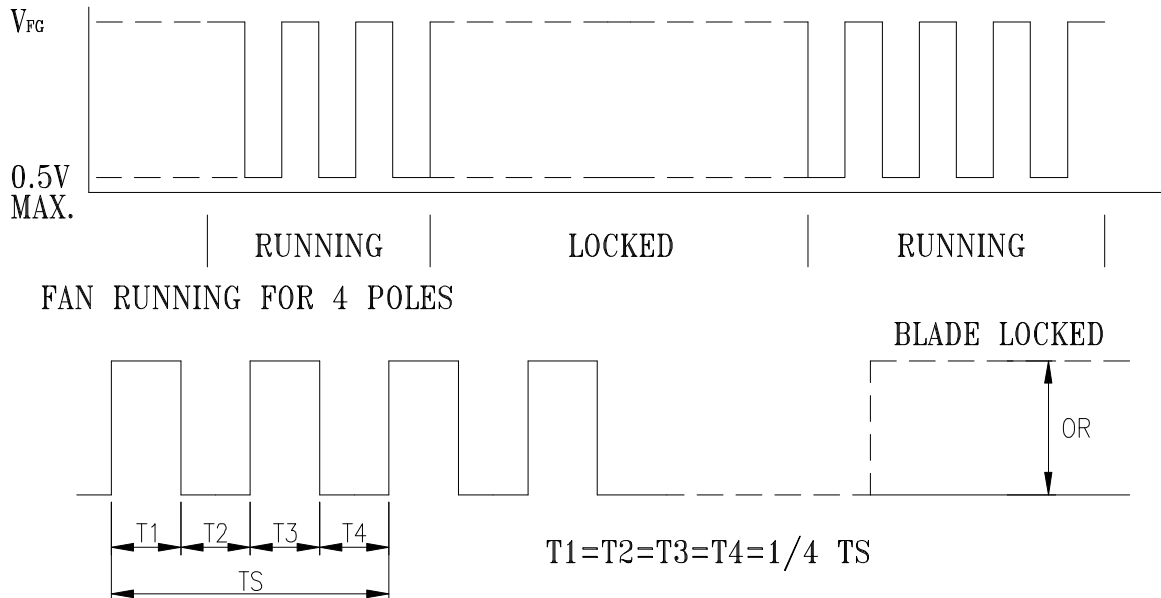

$$N = \text{R.P.M}$$

$$TS = 60 / N (\text{SEC})$$

*VOLTAGE LEVEL AFTER BLADE LOCKED

*4 POLES



Descriptions:

- 1. Delta will not guarantee the performance of the products if the application condition falls outside the parameters set forth in the specification.**
- 2. A written request should be submitted to Delta prior to approval if deviation from this specification is required.**
- 3. Please exercise caution when handling fans. Damage may be caused when pressure is applied to the impeller, if the fans are handled by the lead wires, or if the fans are hard-dropped to the production floor.**
- 4. Except as pertains to some special designs, there is no guarantee that the products will be free from any such safety problems or failures as caused by the introduction of powder, droplets of water or encroachment of insect into the hub.**
- 5. The above-mentioned conditions are representative of some unique examples and viewed as the first point of reference prior to all other information.**
- 6. It is very important to establish the correct polarity before connecting the fan to the power source. Positive (+) and Negative (-). Damage may be caused to the fans if connection is with reverse polarity, as there is no foolproof method to protect against such error.**
- 7. Delta fans are not suitable where any corrosive fluids are introduced to their environment.**
- 8. Please ensure all fans are stored according to the storage temperature limits specified. Do not store fans in a high humidity environment. We highly recommend performance testing is conducted before shipping, if the fans have been stored over 6 months.**
- 9. Not all fans are provided with the Lock Rotor Protection feature. If you impair the rotation of the impeller for the fans that do not have this function, the performance of those fans will lead to failure.**
- 10. Please be cautious when mounting the fan. Incorrect mounting of fans may cause excess resonance, vibration and subsequent noise.**
- 11. It is important to consider safety when testing the fans. A suitable fan guard should be fitted to the fan to guard against any potential for personal injury.**
- 12. Except where specifically stated, all tests are carried out at relative (ambient) temperature and humidity conditions of 25°C, 65%. The test value is only for fan performance itself.**
- 13. Be certain to connect an “over 4.7µF” capacitor to the fan externally when the application calls for using multiple fans in parallel, to avoid any unstable power.**