

(DUST CAPS NOT SHOWN)

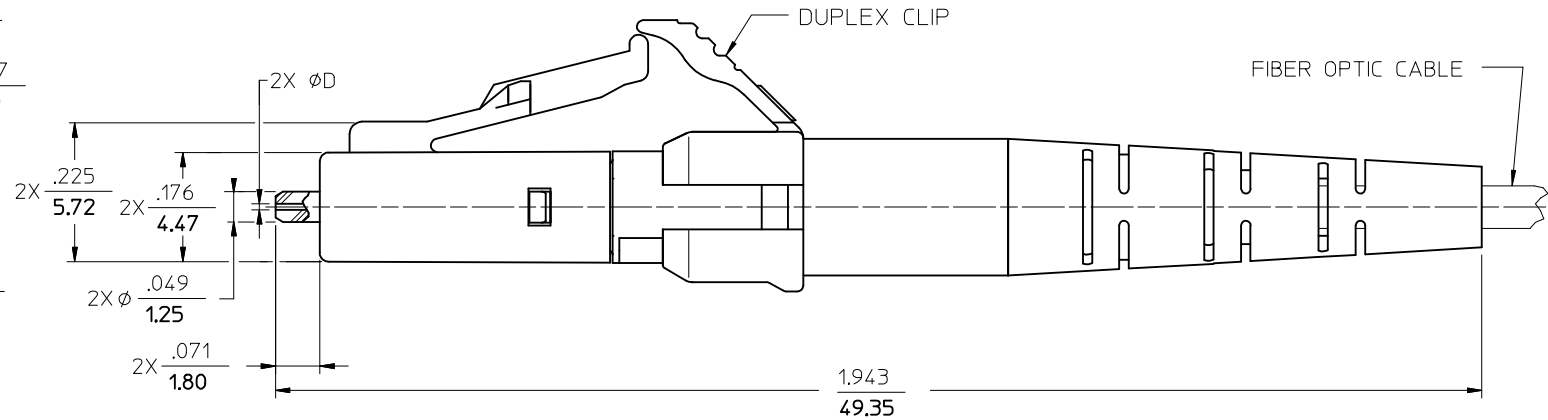
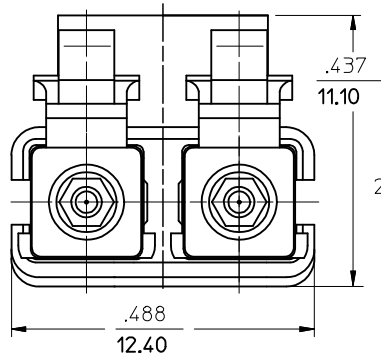

NOTES:

- 1. DUPLEX CLIP AND BOOTS SHOULD BE ASSEMBLED AFTER POLISHING OPERATION.
- \*2. P/N 106025-3320 AND 106025-5320 ARE BULK PACKED IN QUANTITIES OF 100 PCS.

|                                                                                                                       |                                                                                                                               |                                                                                                                                                                |                                                                                                        |                                                                |                              |
|-----------------------------------------------------------------------------------------------------------------------|-------------------------------------------------------------------------------------------------------------------------------|----------------------------------------------------------------------------------------------------------------------------------------------------------------|--------------------------------------------------------------------------------------------------------|----------------------------------------------------------------|------------------------------|
| <b>ENTER DESCRIPTION</b><br>EC NO: MF2013-0203<br>DR: MANKPEVNER 2012/10/09<br>CHKD:<br>APPR: LGUMIN 2012/10/09<br>B1 | QUALITY SYMBOLS<br>▽=0<br>▽=0                                                                                                 | GENERAL TOLERANCES (UNLESS SPECIFIED)<br>mm INCH<br>4 PLACES ± --- ± ---<br>3 PLACES ± --- ± ---<br>2 PLACES ± --- ± ---<br>1 PLACE ± --- ± ---<br>0 PLACE ± ± | DIMENSION STYLE<br>IN/MM<br>DRAWN BY DATE<br>PGIBLIN 2005/09/06<br>CHECKED BY DATE<br>APPROVED BY DATE | SCALE<br>5:1<br>DESIGN UNITS<br>INCH<br>THIRD ANGLE PROJECTION | TITLE<br>LC DUPLEX CONNECTOR |
|                                                                                                                       | ANGULAR ±1/2°<br>DRAFT WHERE APPLICABLE<br>MUST REMAIN WITHIN DIMENSIONS                                                      | MATERIAL NO.<br>SEE TABLE                                                                                                                                      | DOCUMENT NO.<br>SD-1060DD-DDD0                                                                         | SHEET NO.<br>1 OF 1                                            |                              |
|                                                                                                                       | THIS DRAWING CONTAINS INFORMATION THAT IS PROPRIETARY TO MOLEX INCORPORATED AND SHOULD NOT BE USED WITHOUT WRITTEN PERMISSION |                                                                                                                                                                |                                                                                                        |                                                                |                              |
|                                                                                                                       | moxex                                                                                                                         |                                                                                                                                                                |                                                                                                        |                                                                |                              |

| 6             | 5                          | 4                    | 3          | 2                          | 1           |  |
|---------------|----------------------------|----------------------|------------|----------------------------|-------------|--|
| CONNECTOR P/N | ∅D (µm)                    | CONNECTOR BODY COLOR | BOOT COLOR | CABLE DESCRIPTION & ∅ (mm) | CABLE TYPE  |  |
| 106025-2000   | 125.50                     | BLUE                 | WHITE      | SIMPLEX 1.6                | SINGLE MODE |  |
| 106025-2300   |                            |                      |            | SIMPLEX 2.0<br>ZIPCORD 1.6 |             |  |
| 106025-2310   |                            |                      | BLACK      |                            |             |  |
| 106025-3000   | 127.00                     | BEIGE                | WHITE      | SIMPLEX 1.6                | MULTIMODE   |  |
| 106025-3300   |                            |                      |            | SIMPLEX 2.0<br>ZIPCORD 1.6 |             |  |
| 106025-3320*  |                            |                      |            |                            |             |  |
| 106025-3310   |                            |                      | BLUE       |                            |             |  |
| 106025-4000   | 125.00                     | BLUE                 | WHITE      | SIMPLEX 1.6                | SINGLE MODE |  |
| 106025-4300   |                            |                      |            | SIMPLEX 2.0<br>ZIPCORD 1.6 |             |  |
| 106025-5000   | SIMPLEX 1.6                |                      |            |                            |             |  |
| 106025-5300   | SIMPLEX 2.0<br>ZIPCORD 1.6 |                      |            |                            |             |  |
| 106025-5320*  |                            |                      |            |                            |             |  |
| 106025-5310   | BLUE                       |                      |            |                            |             |  |
| 106025-6000   | 125.25                     |                      | WHITE      | SIMPLEX 1.6                |             |  |
| 106025-6300   |                            |                      |            | SIMPLEX 2.0<br>ZIPCORD 1.6 |             |  |

|                                                                                                                                  |                 |                                                      |       |                                 |                     |                       |                                     |                        |  |
|----------------------------------------------------------------------------------------------------------------------------------|-----------------|------------------------------------------------------|-------|---------------------------------|---------------------|-----------------------|-------------------------------------|------------------------|--|
| <b>ENTER DESCRIPTION</b><br>EC NO: MF2013-0203<br>DRWN:KPEVZNER 2012/10/09<br>CHKD:<br>APPR:IGUMIN 2012/10/09<br>REV DESCRIPTION | QUALITY SYMBOLS | GENERAL TOLERANCES (UNLESS SPECIFIED)                |       | DIMENSION STYLE<br><b>IN/MM</b> |                     | SCALE<br><b>5:1</b>   | DESIGN UNITS<br><b>INCH</b>         | THIRD ANGLE PROJECTION |  |
|                                                                                                                                  |                 |                                                      | mm    | INCH                            | DRAWN BY<br>PGIBLIN | DATE<br>2005/09/06    | TITLE<br><b>LC DUPLEX CONNECTOR</b> |                        |  |
|                                                                                                                                  |                 | 4 PLACES                                             | ± --- | ± ---                           | CHECKED BY          | DATE                  |                                     |                        |  |
|                                                                                                                                  |                 | 3 PLACES                                             | ± --- | ± ---                           | APPROVED BY         | DATE                  |                                     |                        |  |
|                                                                                                                                  |                 | 2 PLACES                                             | ± --- | ± ---                           |                     |                       |                                     |                        |  |
|                                                                                                                                  |                 | 1 PLACE                                              | ± --- | ± ---                           |                     |                       |                                     |                        |  |
| 0 PLACE                                                                                                                          | ±               | ±                                                    |       |                                 |                     |                       |                                     |                        |  |
|                                                                                                                                  |                 | ANGULAR ±1/2°                                        |       | MATERIAL NO.                    | DOCUMENT NO.        | SHEET NO.             |                                     |                        |  |
| <b>B1</b>                                                                                                                        | REV             | DRAFT WHERE APPLICABLE MUST REMAIN WITHIN DIMENSIONS |       | <b>SEE TABLE</b>                |                     | <b>SD-1060DD-DDD0</b> |                                     | 2 OF 1                 |  |
| <b>molex</b>                                                                                                                     |                 |                                                      |       |                                 |                     |                       |                                     |                        |  |
| THIS DRAWING CONTAINS INFORMATION THAT IS PROPRIETARY TO MOLEX INCORPORATED AND SHOULD NOT BE USED WITHOUT WRITTEN PERMISSION    |                 |                                                      |       |                                 |                     |                       |                                     |                        |  |