

Recommended PCB Layout

Bottom Entry
 Solder Area

Recommended PCB Layout

Top Entry
 Solder Area

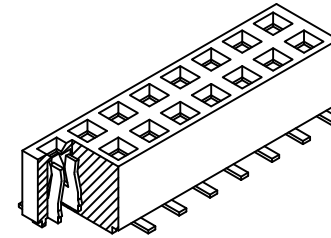
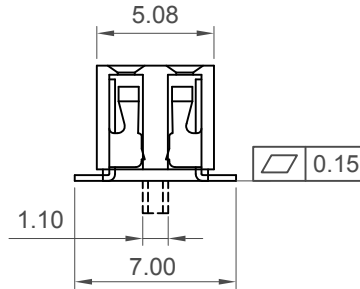
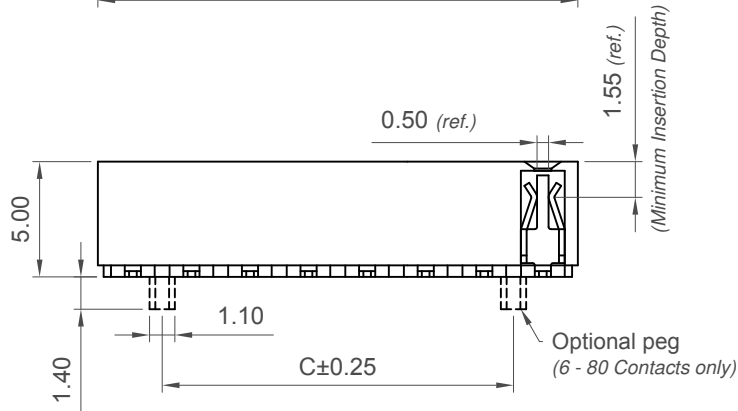

Specifications 规格

Material 物料

Contact 端子: Phosphor Bronze
 Insulator Material 绝缘体:
 Standard 标准: Polyamide, Nylon 6T, UL 94V-0
 Options 可选: Polymer, LCP, UL 94V-0

Electrical 电气

Current Rating 电流额定值: 3 Amp Per Pin
 Insulator Resistance 绝缘电阻值: 1000 MΩ min.
 Contact Resistance 接触电阻值: 20 mΩ max.
 Dielectric Withstanding 耐电压: AC 600 V

Environmental & Mechanical 机械 & 环境

Operating Temperature 工作温度: -40° to +105°C
 Soldering Process 可焊性:

Nylon 6T (Standard 标准物料) -
 IR Reflow 回流焊: 260°C for 10 sec.
 Wave 波峰焊: 230°C for 5-10 sec
 Manual Solder 人工焊接: 350°C for 3-5 sec
 LCP (Option 可选物料) -
 IR Reflow 回流焊: 260°C for 10 sec.
 Wave 波峰焊: 250°C for 5-10 sec
 Manual Solder 人工焊接: 350°C for 3-5 sec

Mates with 配套之公头 (subject to pin length 在端子长度适合的条件下)
 BG025 BG040 BG041 BG045 BG050
 BG065 BG066 BG070 BG085

For bottom entry applications, stringent soldering control & pin alignment are required as lead to pad misalignment could cause incorrect mating.

Ordering Grid



No. of Contacts
 04 to 80

Contact Plating
A = Gold Flash (Standard)
 B = Selective Gold Flash
 C = Tin
 G = 10u" Selective Gold
 I = 30u" Selective Gold

Packing Options

C = Tape and Reel with Film (Standard)
 B = Tape and Reel with Cap
 D = Tube
 E = Tube with Cap
 F = Tube with Film

Insulator Material

N = Nylon 6T (Standard)
 L = LCP

Locating Peg

0 = No Peg
 1 = With Peg (6 - 80 Pins Only)

Number of Contacts	Dimensions		
	A	B	C
4	2.54	5.58	N/A
6	5.08	8.12	2.54
8	7.62	10.66	5.08
10	10.16	13.20	7.62
12	12.70	15.74	10.16
14	15.24	18.28	12.70
16	17.78	20.82	15.24
18	20.32	23.36	17.78
20	22.86	25.90	20.32
22	25.40	28.44	22.86
24	27.94	30.98	25.40
26	30.48	33.52	27.94
28	33.02	36.06	30.48
30	35.56	38.60	33.02
32	38.10	41.14	35.56
34	40.64	43.68	38.10
36	43.18	46.22	40.64
38	45.72	48.76	43.18
40	48.26	51.30	45.72
42	50.80	53.84	48.26
44	53.34	56.38	50.80
46	55.88	58.92	53.34
48	58.42	61.46	55.88
50	60.96	64.00	58.42
52	63.50	66.54	60.96
54	66.04	69.08	63.50
56	68.58	71.62	66.04
58	71.12	74.16	68.58
60	73.66	76.70	71.12
62	76.20	79.24	73.66
64	78.74	81.78	76.20
66	81.28	84.32	78.74
68	83.82	86.86	81.28
70	86.36	89.40	83.82
72	88.90	91.94	86.36
74	91.44	94.48	88.90
76	93.98	97.02	91.44
78	96.52	99.56	93.98
80	99.06	102.10	96.52

Part Number		Product Description	
BG120		2.54mm Pitch Socket	
Drawing Date		Dual Row, Surface Mount, Vertical, Dual Entry	
30th October 2006			
By	CC	Tolerances (Except as Noted)	Units:
Detail	BG120 D PCN	Length X ± 0.30 D PCN X.X ± 0.20	Metric (mm)
Revision	D1	Angle X° ± 5° X.XX° ± 2°	RoHS COMPLIANT 2011/65/EU
Date	21/06/17	X.XXX ± 0.15 X.XXXX ± 0.51	Deca-SIDE

This drawing is confidential and copyright of Global Connector Technology, Ltd (GCT). This drawing must not be copied or disclosed without written consent. E & OE



www.gct.co

Not to Scale	Drawn By AJO	Sheet No. 1/1
--------------	--------------	---------------