



LoRa[®] Mote User's Guide

Note the following details of the code protection feature on Microchip devices:

- Microchip products meet the specification contained in their particular Microchip Data Sheet.
- Microchip believes that its family of products is one of the most secure families of its kind on the market today, when used in the intended manner and under normal conditions.
- There are dishonest and possibly illegal methods used to breach the code protection feature. All of these methods, to our knowledge, require using the Microchip products in a manner outside the operating specifications contained in Microchip's Data Sheets. Most likely, the person doing so is engaged in theft of intellectual property.
- Microchip is willing to work with the customer who is concerned about the integrity of their code.
- Neither Microchip nor any other semiconductor manufacturer can guarantee the security of their code. Code protection does not mean that we are guaranteeing the product as "unbreakable."

Code protection is constantly evolving. We at Microchip are committed to continuously improving the code protection features of our products. Attempts to break Microchip's code protection feature may be a violation of the Digital Millennium Copyright Act. If such acts allow unauthorized access to your software or other copyrighted work, you may have a right to sue for relief under that Act.

Information contained in this publication regarding device applications and the like is provided only for your convenience and may be superseded by updates. It is your responsibility to ensure that your application meets with your specifications. MICROCHIP MAKES NO REPRESENTATIONS OR WARRANTIES OF ANY KIND WHETHER EXPRESS OR IMPLIED, WRITTEN OR ORAL, STATUTORY OR OTHERWISE, RELATED TO THE INFORMATION, INCLUDING BUT NOT LIMITED TO ITS CONDITION, QUALITY, PERFORMANCE, MERCHANTABILITY OR FITNESS FOR PURPOSE. Microchip disclaims all liability arising from this information and its use. Use of Microchip devices in life support and/or safety applications is entirely at the buyer's risk, and the buyer agrees to defend, indemnify and hold harmless Microchip from any and all damages, claims, suits, or expenses resulting from such use. No licenses are conveyed, implicitly or otherwise, under any Microchip intellectual property rights unless otherwise stated.

Microchip received ISO/TS-16949:2009 certification for its worldwide headquarters, design and wafer fabrication facilities in Chandler and Tempe, Arizona; Gresham, Oregon and design centers in California and India. The Company's quality system processes and procedures are for its PIC® MCUs and dsPIC® DSCs, KEELoC® code hopping devices, Serial EEPROMs, microperipherals, nonvolatile memory and analog products. In addition, Microchip's quality system for the design and manufacture of development systems is ISO 9001:2000 certified.

**QUALITY MANAGEMENT SYSTEM
CERTIFIED BY DNV
= ISO/TS 16949 =**

Trademarks

The Microchip name and logo, the Microchip logo, AnyRate, dsPIC, FlashFlex, flexPWR, Heldo, JukeBlox, KeeLoq, KeeLoq logo, Klear, LANCheck, LINK MD, MediaLB, MOST, MOST logo, MPLAB, OptoLyzer, PIC, PICSTART, PIC32 logo, RightTouch, SpyNIC, SST, SST Logo, SuperFlash and UNI/O are registered trademarks of Microchip Technology Incorporated in the U.S.A. and other countries.

ClockWorks, The Embedded Control Solutions Company, ETHERSYNCH, Hyper Speed Control, HyperLight Load, IntelliMOS, mTouch, Precision Edge, and QUIET-WIRE are registered trademarks of Microchip Technology Incorporated in the U.S.A.

Analog-for-the-Digital Age, Any Capacitor, AnyIn, AnyOut, BodyCom, chipKIT, chipKIT logo, CodeGuard, dsPICDEM, dsPICDEM.net, Dynamic Average Matching, DAM, ECAN, EtherGREEN, In-Circuit Serial Programming, ICSP, Inter-Chip Connectivity, JitterBlocker, KlearNet, KlearNet logo, MiWi, motorBench, MPASM, MPF, MPLAB Certified logo, MPLIB, MPLINK, MultiTRAK, NetDetach, Omniscient Code Generation, PICDEM, PICDEM.net, PICKit, PICtail, PureSilicon, RightTouch logo, REAL ICE, Ripple Blocker, Serial Quad I/O, SQL, SuperSwitcher, SuperSwitcher II, Total Endurance, TSHARC, USBCheck, VariSense, ViewSpan, WiperLock, Wireless DNA, and ZENA are trademarks of Microchip Technology Incorporated in the U.S.A. and other countries.

SQTP is a service mark of Microchip Technology Incorporated in the U.S.A.

Silicon Storage Technology is a registered trademark of Microchip Technology Inc. in other countries.

GestIC is a registered trademarks of Microchip Technology Germany II GmbH & Co. KG, a subsidiary of Microchip Technology Inc., in other countries.

All other trademarks mentioned herein are property of their respective companies.

© 2015-2016, Microchip Technology Incorporated, Printed in the U.S.A., All Rights Reserved.

ISBN: 978-1-5224-0550-4

Object of Declaration: LoRa® Mote

EU Declaration of Conformity

Manufacturer: Microchip Technology Inc.
2355 W. Chandler Blvd.
Chandler, Arizona, 85224-6199
USA

This declaration of conformity is issued by the manufacturer.

The development/evaluation tool is designed to be used for research and development in a laboratory environment. This development/evaluation tool is not a Finished Appliance, nor is it intended for incorporation into Finished Appliances that are made commercially available as single functional units to end users under EU EMC Directive 2004/108/EC and as supported by the European Commission's Guide for the EMC Directive 2004/108/EC (8th February 2010).

This development/evaluation tool complies with EU RoHS2 Directive 2011/65/EU.

This development/evaluation tool, when incorporating wireless and radio-telecom functionality, is in compliance with the essential requirement and other relevant provisions of the R&TTE Directive 1999/5/EC and the FCC rules as stated in the declaration of conformity provided in the module datasheet and the module product page available at www.microchip.com.

For information regarding the exclusive, limited warranties applicable to Microchip products, please see Microchip's standard terms and conditions of sale, which are printed on our sales documentation and available at www.microchip.com.

Signed for and on behalf of Microchip Technology Inc. at Chandler, Arizona, USA

Derek Carlson
VP Development Tools

12-Sep-14
Date

LoRa[®] Mote User's Guide

NOTES:

Table of Contents

| | |
|--|-----------|
| Preface | 7 |
| Chapter 1. Introduction | |
| 1.1 Overview | 11 |
| 1.2 Features | 11 |
| 1.3 Contents | 12 |
| Chapter 2. Getting Started | |
| 2.1 Introduction | 13 |
| 2.2 Methods of Operation | 13 |
| 2.2.1 USB | 13 |
| 2.2.2 Battery | 13 |
| 2.3 Hardware Description | 14 |
| 2.4 Mote Application Description | 17 |
| 2.4.1 USB CDC-Serial | 17 |
| 2.4.2 Mobile Mote Sensor Emulation | 17 |
| 2.4.3 Bootloader Behavior | 18 |
| 2.4.4 Application Updates | 19 |
| Appendix A. Board of Schematics and Bill of Materials | |
| A.1 Introduction | 21 |
| A.2 Board Schematics | 21 |
| A.3 Bill of Materials | 24 |
| Appendix B. Legacy Board Schematics and Bill of Materials | |
| B.1 Introduction | 25 |
| B.2 Differences | 25 |
| B.3 Board Schematics | 29 |
| B.4 Bill of Materials | 31 |
| Worldwide Sales and Service | 33 |

LoRa[®] Mote User's Guide

NOTES:

Preface

NOTICE TO CUSTOMERS

All documentation becomes dated, and this manual is no exception. Microchip tools and documentation are constantly evolving to meet customer needs, so some actual dialogs and/or tool descriptions may differ from those in this document. Please refer to our website (www.microchip.com) to obtain the latest documentation available.

Documents are identified with a “DS” number. This number is located on the bottom of each page, in front of the page number. The numbering convention for the DS number is “DSXXXXXXXXA”, where “XXXXXXXX” is the document number and “A” is the revision level of the document.

For the most up-to-date information on development tools, see the MPLAB® IDE online help. Select the Help menu, and then Topics to open a list of available online help files.

INTRODUCTION

This chapter contains general information that will be useful to know before using the LoRa® Mote and attached LoRa® Technology Module. Topics discussed in this chapter include:

- [Document Layout](#)
- [Conventions Used in this Guide](#)
- [Recommended Reading](#)
- [The Microchip Website](#)
- [Development Systems Customer Change Notification Service](#)
- [Customer Support](#)
- [Revision History](#)

DOCUMENT LAYOUT

This document describes how to use the LoRa® Mote as a demonstration to show how LoRa technology communication works. The document is organized as follows:

- **Chapter 1. “Introduction”** – This chapter describes the LoRa® Mote and presents various modes of operation.
- **Chapter 2. “Getting Started”** – This chapter describes the two main communication methods, and the hardware requirements for getting started with the LoRa® Mote.
- **Appendix A. “Board of Schematics and Bill of Materials”** – This appendix provides the LoRa® Mote schematics and the Bill of Materials (BOM).
- **Appendix B. “Legacy Board Schematics and Bill of Materials”** – This appendix provides the LoRa® Mote schematics and the Bill of Materials (BOM) for the Legacy Mote Design; along with brief descriptions of changes between designs.

CONVENTIONS USED IN THIS GUIDE

This manual uses the following documentation conventions:

DOCUMENTATION CONVENTIONS

| Description | Represents | Examples |
|--|---|---|
| Arial font: | | |
| Italic characters | Referenced books | <i>MPLAB[®] IDE User's Guide</i> |
| | Emphasized text | ...is the <i>only</i> compiler... |
| Initial caps | A window | the Output window |
| | A dialog | the Settings dialog |
| | A menu selection | select Enable Programmer |
| Quotes | A field name in a window or dialog | "Save project before build" |
| Underlined, italic text with right angle bracket | A menu path | <u><i>File>Save</i></u> |
| Bold characters | A dialog button | Click OK |
| | A tab | Click the Power tab |
| N'Rnnnn | A number in verilog format, where N is the total number of digits, R is the radix and n is a digit. | 4'b0010, 2'hF1 |
| Text in angle brackets < > | A key on the keyboard | Press <Enter>, <F1> |
| Courier New font: | | |
| Plain Courier New | Sample source code | #define START |
| | Filenames | autoexec.bat |
| | File paths | c:\mcc18\h |
| | Keywords | _asm, _endasm, static |
| | Command-line options | -Opa+, -Opa- |
| | Bit values | 0, 1 |
| | Constants | 0xFF, 'A' |
| Italic Courier New | A variable argument | <i>file.o</i> , where <i>file</i> can be any valid filename |
| Square brackets [] | Optional arguments | mcc18 [options] <i>file</i> [options] |
| Curly brackets and pipe character: { } | Choice of mutually exclusive arguments; an OR selection | errorlevel {0 1} |
| Ellipses... | Replaces repeated text | var_name [, var_name...] |
| | Represents code supplied by user | void main (void) { ... } |

RECOMMENDED READING

This user's guide describes how to use the LoRa[®] Mote. Other useful documents are listed below. The following Microchip documents are available and recommended as supplemental reference resources:

RN2483 Low-Power Long-Range LoRa[®] Technology Transceiver Module Data Sheet (DS50002346)

This data sheet provides detailed specifications for the RN2483 module.

RN2483 LoRa[®] Technology Module Command Reference User's Guide (DS40001784)

This user's guide provides specifications about the commands to be used with the LoRa[®] module.

RN2483 LoRa[®] Technology PICtail™/PICtail Plus Daughter Board User's Guide (DS50002366)

This user's guide describes how to configure and use the LoRa[®] Daughter Board.

RN2903 Low-Power Long-Range LoRa[®] Technology Transceiver Module Data Sheet (DS50002390)

This data sheet provides detailed specifications for the RN2903 module.

RN2903 LoRa[®] Technology Module Command Reference User's Guide (DS40001811)

This user's guide provides specifications about the commands to be used with the LoRa[®] module.

RN2903 LoRa[®] Technology PICtail™/PICtail Plus Daughter Board User's Guide (DS50002424)

This user's guide describes how to configure and use the LoRa[®] Daughter Board.

LoRa[®] Technology Evaluation Suite User's Guide (DS40001847)

This user's guide describes how to use the LoRa[®] Technology Evaluation Kit along with the LoRa Development Utility Application Graphic User Interface (GUI) as a demonstration platform to show how to create and manage a LoRa Technology Network.

To obtain any of Microchip's documents, visit the Microchip website at www.microchip.com.

THE MICROCHIP WEBSITE

Microchip provides online support via our website at www.microchip.com. This website is used as a means to make files and information easily available to customers. Accessible by using your favorite Internet browser, the website contains the following information:

- **Product Support** – Data sheets and errata, application notes and sample programs, design resources, user's guides and hardware support documents, latest software releases and archived software
- **General Technical Support** – Frequently Asked Questions (FAQs), technical support requests, online discussion groups, Microchip consultant program member listing
- **Business of Microchip** – Product selector and ordering guides, latest Microchip press releases, listing of seminars and events, listings of Microchip sales offices, distributors and factory representatives

DEVELOPMENT SYSTEMS CUSTOMER CHANGE NOTIFICATION SERVICE

Microchip's customer notification service helps keep customers current on Microchip products. Subscribers will receive e-mail notification whenever there are changes, updates, revisions or errata related to a specified product family or development tool of interest.

To register, access the Microchip website at www.microchip.com, click on Customer Change Notification and follow the registration instructions.

The Development Systems product group categories are:

- **Compilers** – The latest information on Microchip C compilers, assemblers, linkers and other language tools. These include all MPLAB C compilers; all MPLAB assemblers (including MPASM[™] assembler); all MPLAB linkers (including MPLINK[™] object linker); and all MPLAB librarians (including MPLIB[™] object librarian).
- **Emulators** – The latest information on Microchip in-circuit emulators. This includes the MPLAB REAL ICE[™] and MPLAB ICE 2000 in-circuit emulators.
- **In-Circuit Debuggers** – The latest information on the Microchip in-circuit debuggers. This includes MPLAB ICD 3 in-circuit debuggers and PICKit[™] 3 debug express.
- **MPLAB[®] X IDE** – The latest information on Microchip MPLAB IDE, the Windows[®] Integrated Development Environment for development systems tools. This list is focused on the MPLAB IDE, MPLAB IDE Project Manager, MPLAB Editor and MPLAB SIM simulator, as well as general editing and debugging features.
- **Programmers** – The latest information on Microchip programmers. These include production programmers such as MPLAB REAL ICE in-circuit emulator, MPLAB ICD 3 in-circuit debugger and MPLAB PM3 device programmers. Also included are nonproduction development programmers such as PICSTART[®] Plus and PICKit 2 and 3.

CUSTOMER SUPPORT

Users of Microchip products can receive assistance through several channels:

- Distributor or Representative
- Local Sales Office
- Field Application Engineer (FAE)
- Technical Support

Customers should contact their distributor, representative or field application engineer (FAE) for support. Local sales offices are also available to help customers. A listing of sales offices and locations is included in the back of this document.

Technical support is available through the website at:

<http://www.microchip.com/support>.

REVISION HISTORY

Revision A (August 2015)

Initial release of the document.

Revision B (May 2016)

Updated documentation to reflect Revision B of the Mote. Moved Legacy Mote material to Appendix Section; along with notes on the difference between devices.

Chapter 1. Introduction

1.1 OVERVIEW

The LoRa[®] Mote is a demonstration board that showcases the Microchip Low-Power Long Range LoRa[®] Technology Transceiver Module.

The LoRa[®] Mote provides access to the module through a convenient USB-to-UART bridge chip and supports connection points to all GPIO-controlled module pins.

This chapter discusses the following topics:

- [Features](#)
- [Contents](#)

1.2 FEATURES

The LoRa[®] Mote has the following features, as represented in [Figure 1-1](#):

1. 868/915 MHz High-Frequency SMA Connector
2. 433 MHz Low-Frequency Antenna Point
3. RN Module ICSP[™] Programming Through Holes
4. Module Breakout Header 1
5. Module Breakout Header 2
6. Microchip LoRa[®] Module
7. Mote ICSP Programming Through Holes
8. Green LED controlled by RN Module GPIO10
9. Orange LED controlled by RN Module GPIO11
10. Backlight LCD Display; 1.2 Inch 128 X 32 Dot Matrix
11. S1 Switch (Navigation)
12. S2 Switch (Selection)
13. Everlight (ALS-PT19-315C) Ambient Light Sensor
14. Alternative Power Supply Through Hole Connectors
15. MCP1825S – LDO Regulator
16. PIC18LF45K50 8-bit USB XLP Flash 32Kb MCU
17. MCP9700 – Linear Active Thermistor
18. Battery Power Switch
19. Mote Power Indicator Red LED
20. Red LED controlled by MCU pin RA7 (28)
21. Green LED controlled by MCU pin RA6 (29)
22. USB Micro-B Connector
23. LCD Ribbon Connector
24. LCD Backlight Power Connector
25. (2) AAA Battery Pack

LoRa[®] Mote User's Guide

FIGURE 1-1: LoRa[®] MOTE

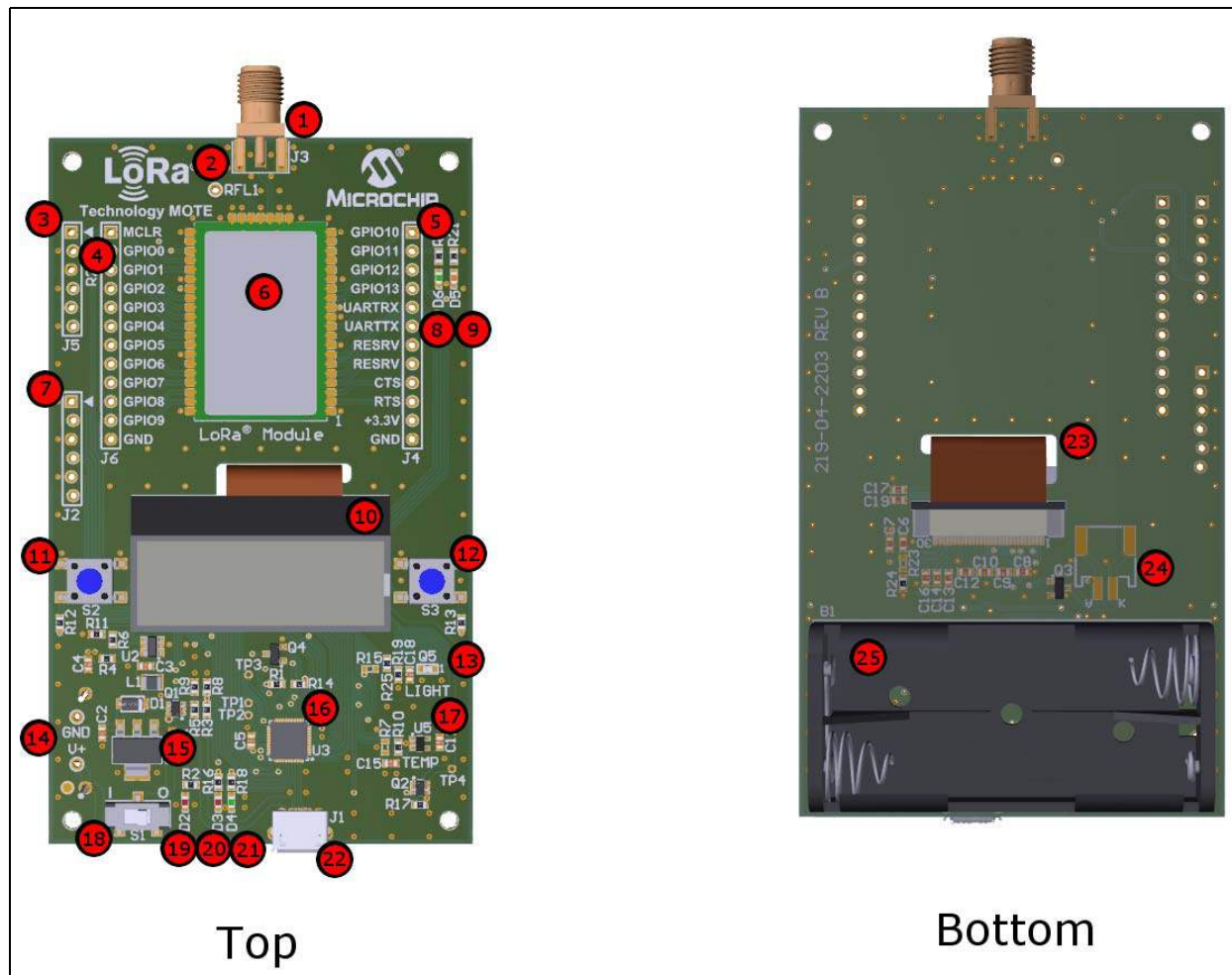

The high-speed UART interface and the GPIO ports are available on the module to configure, control and transfer data. The Mote board has an on-board PIC18 supporting USB-to-UART serial bridge, enabling easy serial connection.

Demonstration of the module can be performed by plugging the Mote into a USB port of a PC. The USB port powers the Mote board and enables the user to communicate using the module's ASCII commands.

Development using the module with Microchip's PIC[®] MCU line is possible via the 24-pin card edge connectors on the Mote board.

1.3 CONTENTS

The Mote contains the following tools, as listed in [Table 1-1](#).

TABLE 1-1: LoRa[®] MOTE

| Description |
|--|
| LoRa [®] Mote populated with the LoRa [®] Module |
| USB Cable (Male-A to Male Mini-B) |
| Antenna – 868/915 MHz |

Chapter 2. Getting Started

2.1 INTRODUCTION

This LoRa[®] Mote User's Guide is designed to be used in conjunction with the LoRa Technology Command Reference User's Guide for the on-board LoRa module. This chapter describes the hardware requirements for the LoRa Mote board, and also provides descriptions of the different communication modes.

The module accepts commands via UART interface. Communication with the module is achieved through two methods of operation, USB and Battery.

This chapter discusses the following topics:

- Operation Methods
- Communication to the Module
- Hardware Description

2.2 METHODS OF OPERATION

2.2.1 USB

When the Mote board is connected to the host via USB, the device will operate automatically in USB mode. The on-board PIC18LF45K50 MCU will become a USB-to-UART bridge device. The host can run a simple terminal emulator application to issue commands directly to the module.

When in CDC Command mode, it is possible to operate in Battery mode by pressing either push button. The Mote will only forward Serial commands to the RN module when in CDC Command mode. If running in Battery mode with the USB cable connected; disconnecting and reconnecting the USB cable is required to return to normal USB mode for CDC serial command parsing emulation.

Supply voltage is provided via USB, and is regulated from 5V to the nominal 3.3V using the on-board LDO (U1).

2.2.2 Battery

When no USB cable is attached, and the board is powered by (2) AAA batteries (B1), the Mote is operating in Battery mode.

In Battery Operation mode, the Microchip PIC18LF45K50 PIC[®] MCU on the Mote unit can run custom functions and directly issue ASCII commands to the attached LoRa module via the UART interface.

The on-board MCU influences UART communications specific to operation states. Additional resources exist on the MCU, allowing further custom development by the user.

2.3 HARDWARE DESCRIPTION

The RF signal paths are connected to the SMA edge connector and the designated via through-hole point. The high-frequency (868/915 MHz band) RF signal is transmitted through the RFH (J3) SMA connector. The low-frequency (433 MHz) RF signal is transmitted via the through-hole point (RFL), this allows connection of a user-supplied wire antenna.

Note: The North-American (915 MHz) module does not support the ability to transmit a (433 MHz) low-frequency signal.

The on-board PIC18LF45K50 MCU is programmable via ICSP™ through connector J2. In addition, the PIC18LF45K50 MCU application program is capable of being updated via the bootloader utility.

The Mote board will power-on automatically when a USB cable is connected. When powered by AAA batteries, power-on/off is controlled using the (S3) switch.

Mote environment data is measured by a light sensor (U4) and by a temperature sensor (U5). There are two on-board push buttons (S2, S3) used for menu navigation and selection. In addition, there are four LEDs. Two LEDs (D3-Orange, D4-Green) are connected to the module's GPIO10 and GPIO11 I/O's. Two LEDs (D5-Red, D6-Green) are connected to and controlled by the PIC18LF45K50 device.

Table 2-2 shows the LoRa[®] Mote PIC18LF45K50 connections:

TABLE 2-2: MOTE PIC18LF45K50 USAGE

| PIN | Pin Name | Description | Mote Usage |
|-----------------------------|----------|----------------|--|
| General Purpose Pins | | | |
| PORT A | | | |
| 17 | RA0 | USB_DET | USB Power Detection (Digital, Input) |
| 18 | RA1 | VBAT | Battery Voltage (Analog, ADC) |
| 19 | RA2 | TEMP_SENSE | MCP9700 Thermistor Sensor (Analog, ADC) [NOT USED; Requires {R7} population] |
| 20 | RA3 | LIGHT_SENSE | ALS-PT19-315C Ambient Light Sensor (Analog ,ADC) [NOT USED; Requires {R15} population] |
| 21 | RA4 | TP3 | Test Point 3 [NOT USED] |
| 22 | RA5 | SLEEP_PWR | MOSFET {Q2} Enable/Disable; Used for Sleep Power Current Reduction |
| 29 | RA6 | GREEN_LED | Application Behavior Descriptor (Digital, Output) |
| 28 | RA7 | RED_LED | Application Behavior Descriptor (Digital, Output) |
| PORT B | | | |
| 8 | RB0 | S3 Push Button | Application Navigation Controller (Digital, Input) |
| 9 | RB1 | S2 Push Button | Application Navigation Controller (Digital, Input) |
| 10 | RB2 | DISPRST | LCD Display Dedicated Reset Enable/Disable Pin |
| 11 | RB3 | RD_E | LCD Read Enable/Disable Pin |
| 12 | RB4 | CS | LCD Chip Select Pin |
| 13 | RB5 | MODRST | Dedicated RN Module Reset Enable/Disable Pin |
| 14 | RB6 | PGC | ICSP™ Programmer |
| 15 | RB7 | PGD | ICSP™ Programmer |
| PORT C | | | |
| 30 | RC0 | A0 | LCD Command/Data Select Pin |
| 31 | RC1 | R/W | LCD Read/Write Select Pin |

TABLE 2-2: MOTE PIC18LF45K50 USAGE (CONTINUED)

| PIN | Pin Name | Description | Mote Usage |
|-----------------------------|----------|--------------------------|--|
| General Purpose Pins | | | |
| 32 | RC2 | MODEM_WAKE | Wake from Sleep Via RN Module output [NOT USED] |
| 40 | RC6 | TX | PIC [®] MCU to Module Communication |
| 1 | RC7 | RX | PIC [®] MCU to Module Communication |
| PORT D | | | |
| 34 | RD0 | D0 | 8-bit bidirectional data bus connect to an 8-bit or 16-bit standard MPU data bus |
| 35 | RD1 | D1 | |
| 36 | RD2 | D2 | |
| 37 | RD3 | D3 | |
| 2 | RD4 | D4 | |
| 3 | RD5 | D5 | |
| 4 | RD6 | D6 | |
| 5 | RD7 | D7 | |
| PORT E | | | |
| 23 | RE0 | TP1 | Test Point 1 [NOT USED] |
| 24 | RE1 | TP2 | Test Point 2 [NOT USED] |
| 25 | RE2 | BACKLIGHT | LCD Backlight Power Control (Pulse-Width Modulation, Output) |
| 16 | RE3 | $\overline{\text{MCLR}}$ | ICSP [™] Programmer |
| Dedicated Pin | | | |
| 6,27, 41 | VSS | Ground Reference | Ground Reference |
| 7,26 | VDD | +3.3 V | Power Source |
| 38 | D- | DN | USB Communications |
| 39 | D+ | DP | USB Communications |
| 33 | VUSB3V3 | +3.3 V | Power Reference |

The populated module (U7) is re-programmable via the ICSP[™] press pin pad programming connector point (J5). In addition, the populated LoRa module is capable of being updated via the LoRa[®] bootloader GUI, as described in the *RN2483 LoRa[®] Technology Module Command Reference User's Guide* (DS40001784), *RN2903 LoRa[®] Technology Module Command Reference User's Guide* (DS40001811), or *LoRa[®] Technology Evaluation Suite User's Guide* (DS40001847).

All the pins of the module can be accessed via surface-mount pads located on both sides of the (U7) connection point. The user can mount two 1.27 mm pitched socket headers if desired. Sockets can connect the module pins to a custom board, whereas the Mote board is capable of providing power. The sockets are broken into two header breakout groupings used in supplying connection points to the module's power, ground and additional GPIO/UART pins.

[Table 2-3](#) shows the LoRa module jumper breakout connections.

TABLE 2-3: MODULE JUMPER CONNECTIONS

| Signal Name | Description | Module Pin Connection | Mote Function |
|--------------------------|----------------------|--------------------------------------|--|
| $\overline{\text{MCLR}}$ | Reset | 32 | ICSP™ Programmer; Connected to MODRST (RB5, 13) |
| GPIO0 | General Purpose I/O | 35 | Unused |
| GPIO1 | General Purpose I/O | 36 | Unused |
| GPIO2 | General Purpose I/O | 37 | Unused |
| GPIO3 | General Purpose I/O | 38 | Unused |
| GPIO4 | General Purpose I/O | 39 | Unused |
| GPIO5 | General Purpose I/O | 40 | Unused |
| GPIO6 | General Purpose I/O | 43 | Unused |
| GPIO7 | General Purpose I/O | 44 | Unused |
| GPIO8 | General Purpose I/O | 45 | Unused |
| GPIO9 | General Purpose I/O | 46 | MODEM_WAKE (RC2, 32) |
| GPIO10 | General Purpose I/O | 14 | D5 – Orange LED |
| GPIO11 | General Purpose I/O | 13 | D6 – Green LED |
| GPIO12 | General Purpose I/O | 10 | Connected to Temperature Sensor; MODTMPSENS (Analog, ADC) |
| GPIO13 | General Purpose I/O | 9 | Connected to Ambient Light Sensor; MODLITESENS (Analog, ADC) |
| UARTRX | Module Communication | 7 | PIC [®] MCU TX (RC6, Pin 40) |
| UARTTX | Module Communication | 6 | PIC [®] MCU RX (RC7, Pin 1) |
| CTS | Module Communication | 3 | Unused |
| RTS | Module Communication | 2 | Unused |
| +3.3V | Power Source | 34, 12 | +3.3V Rail |
| GND | Ground Reference | 1,8,11,20,21,22,24,26,27,28,33,41,47 | Ground |

2.4 MOTE APPLICATION DESCRIPTION

This section describes the basic operation of the LoRa Mote application program.

The default LoRa Mote application comes with three methods of operation:

- USB CDC-Serial Communication
- Mobile Mote Sensor Emulation
- Application Update via Bootloader

2.4.1 USB CDC-Serial

When a USB Mini-B is connected to the LoRa Mote, it will power-on, regardless of the power switch S3. If the LoRa Mote is already in operation, the USB connection will take pre-emptive control and act only as a serial emulation device. After being connected to a host PC, the LoRa Mote will enumerate. In this operation mode, the user can enter the required LoRaWAN™ credentials for joining an existing LoRaWAN network.

There is a wide range of third-party serial communication programs which can be used to communicate with the module populated on the LoRa Mote. Refer to the *RN2483 LoRa® Technology Module Command Reference User's Guide* (DS40001784) for additional information on parsing commands directly into the RN module for LoRa communications.

Note: MPCOMMS is required to be installed for USB enumeration. This is installed automatically together with MPLAB® X.

2.4.2 Mobile Mote Sensor Emulation

When powered using (2) AAA batteries, the LoRa Mote will act in Mobile Mote mode. This application is best used to demonstrate a real working Internet of Things (IoT) sensor design.

After power-on, the LoRa Mote will attempt a LoRaWAN network first through either Activation-By-Personalization (ABP) [S2], or Over-The-Air-Activation (OTAA) [S3]; depending upon the type requested. If the proper keys necessary to join the requested process (ABP, OTAA), the LoRa Mote will display the message "Valid Keys Required". The user will then have to enter the required keys of the module through USB CDC-Serial mode, and store them using the 'mac save' command. The minimal required credentials for each join process are indicated below:

- OTAA
 - DevEUI
 - AppEUI
 - AppKey
- ABP
 - DevAddr
 - NwkSKey
 - AppSKey

If the proper credentials are entered, the LoRa Mote will automatically join the system. After joining, the LoRa Mote will enter Running mode.

When running, the LoRa Mote acts as a demonstration device. It is capable of key LoRa communication events, such as manual uplink packets, automatic periodic uplink packets, and displaying last received downlink data.

Menu navigation is handled by using S2 for navigation and S3 for selection.

Table 2-4 shows the menus with operation descriptions:

TABLE 2-4: DESCRIPTION OF MENU OPERATION

| Menu | Description |
|--------------------------------|--|
| Sensor Display | Displays Light and Temperature Sensor Data |
| Issue uplink | (S2) issues a confirmed uplink message with sensor data payload. (S3) issues an unconfirmed uplink message with sensor data payload. ⁽¹⁾ |
| View downlink | When the red LED (D5) is lit, a downlink message is ready for viewing. This menu will display the received downlink payload. |
| Menu Timeout | Configures/Disables the Sleep time-out features of the Mote. Disabling this feature will prevent the Mote to automatically enter sleeping if inactive. If not disabled, the Menu time out contains varying options in length. Menu time-out length is represented in seconds. |
| Perform Periodic Sleep Uplinks | Configures/Disables the ability for the Mote to issue Uplink Transmissions when asleep. Configures the rate at which the Mote is periodically woken from Sleep through use of the Watchdog Timer. Periodic Uplink Transmission lengths are represented in minutes. |
| Select Data Rate | Configures the working Data Rate for the RN module. Available Data Rate options are dependent upon the populated RN module type. Selection of Adaptive Data Rate (ADR) is also available. Upon exiting the menu will issue configuration commands to the RN module where parameter value is "saved". |
| Sleep Control | The LoRa [®] Mote will automatically enter Sleep if no buttons are pressed for 30 seconds. The LoRa Mote can be placed into Sleep manually by selecting the Sleep option in the menus. Wake-Up events include: <ul style="list-style-type: none"> • Pressing either S2 or S3 push buttons • A USB plug-in • Periodic WDT (Watchdog Timer) ticks • Module message reception |

Note 1: The port number used for Mote uplink messages is randomly selected between 1-223.

2.4.3 Bootloader Behavior

The PIC18LF45K50 is pre-programmed with a bootloader application. Bootloader mode is initiated by holding either S2/S3 or both push buttons upon power-up.

The bootloader applications are based off the HID bootloader – PIC18 Non-J; the project is supplied with the Microchip Libraries for Applications (MLA) that can be found at www.microchip.com/mla.

In addition, the utility supplied with the MLA is used to handle all Mote PIC[®] MCU application bootloading behaviors.

Note: Additionally, the module contains its own bootloader application which can be accessed/updated as discussed in the *RN2483 LoRa[®] Technology Module Command Reference User's Guide* (DS40001784)

2.4.4 Application Updates

- If powered by USB cable, the red LED (D3) and the green LED (D4) will begin to alternate ON/OFF.
- If the device is in Battery Operation mode and the Bootloader mode is entered, the red LED (D3) will stay ON, the green LED (D4) will remain OFF. Once the USB cable is plugged-in, the green/red LED will alternate.

The application firmware can be updated by launching the HID bootloader GUI application included with the Microchip Libraries for Applications (MLA) at www.microchip.com/mla.

DIR: \\mlav2014_07_22\apps\usb\device\bootloaders\utilities\bin\win\HIDBootloader.exe

Note: If Bootloader mode is entered unintentionally, power cycling the board will re-enter the LoRa[®] Mote default application.

LoRa[®] Mote User's Guide

NOTES:

Appendix A. Board of Schematics and Bill of Materials

A.1 INTRODUCTION

This appendix provides the LoRa[®] Mote schematics and Bill of Materials (BOM).

- [Board Schematics](#)
- [Bill of Materials](#)

A.2 BOARD SCHEMATICS

[Figure A-1](#) and [Figure A-2](#) show the board schematics.

FIGURE A-1: LoRa® MOTE BOARD SCHEMATIC 1

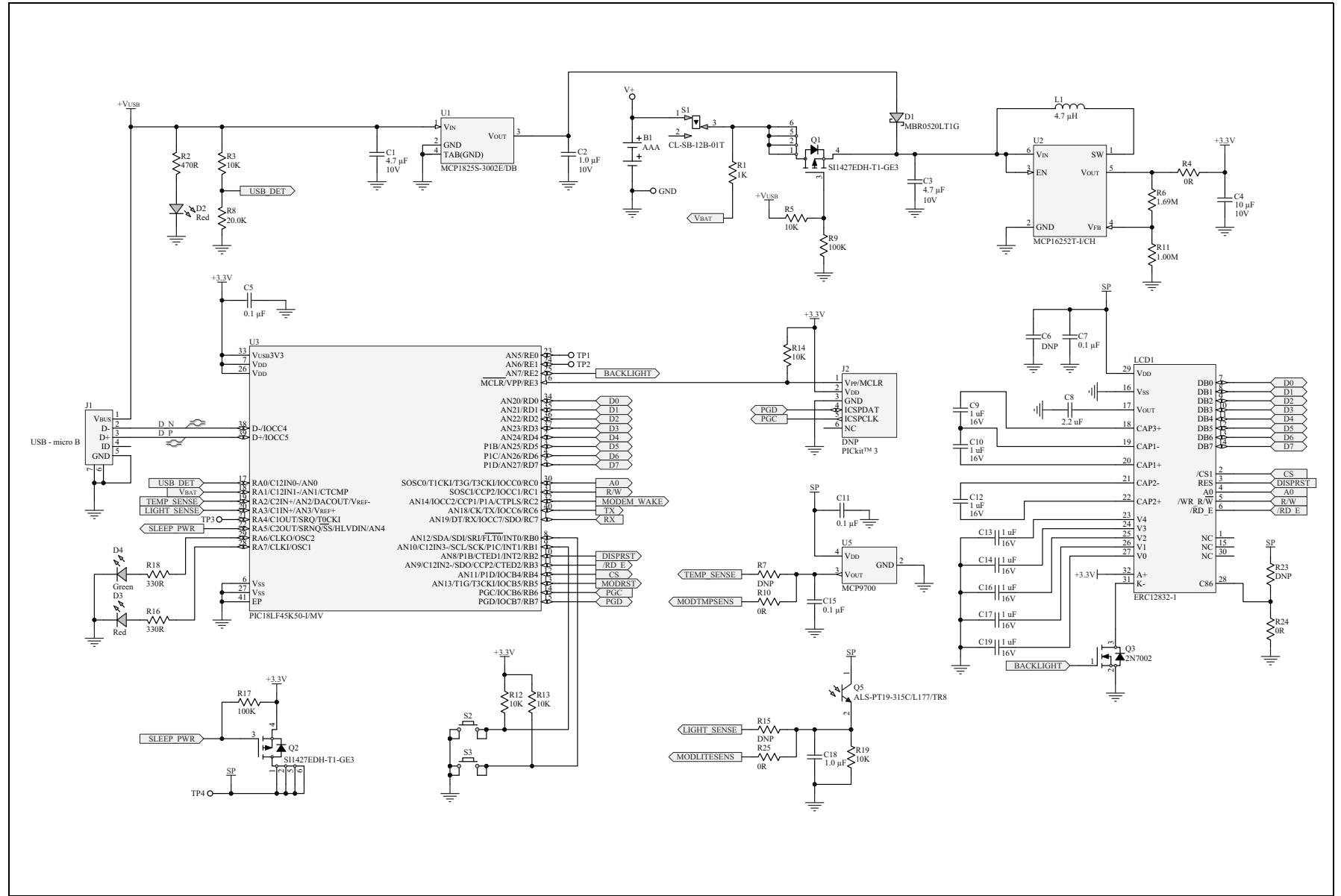
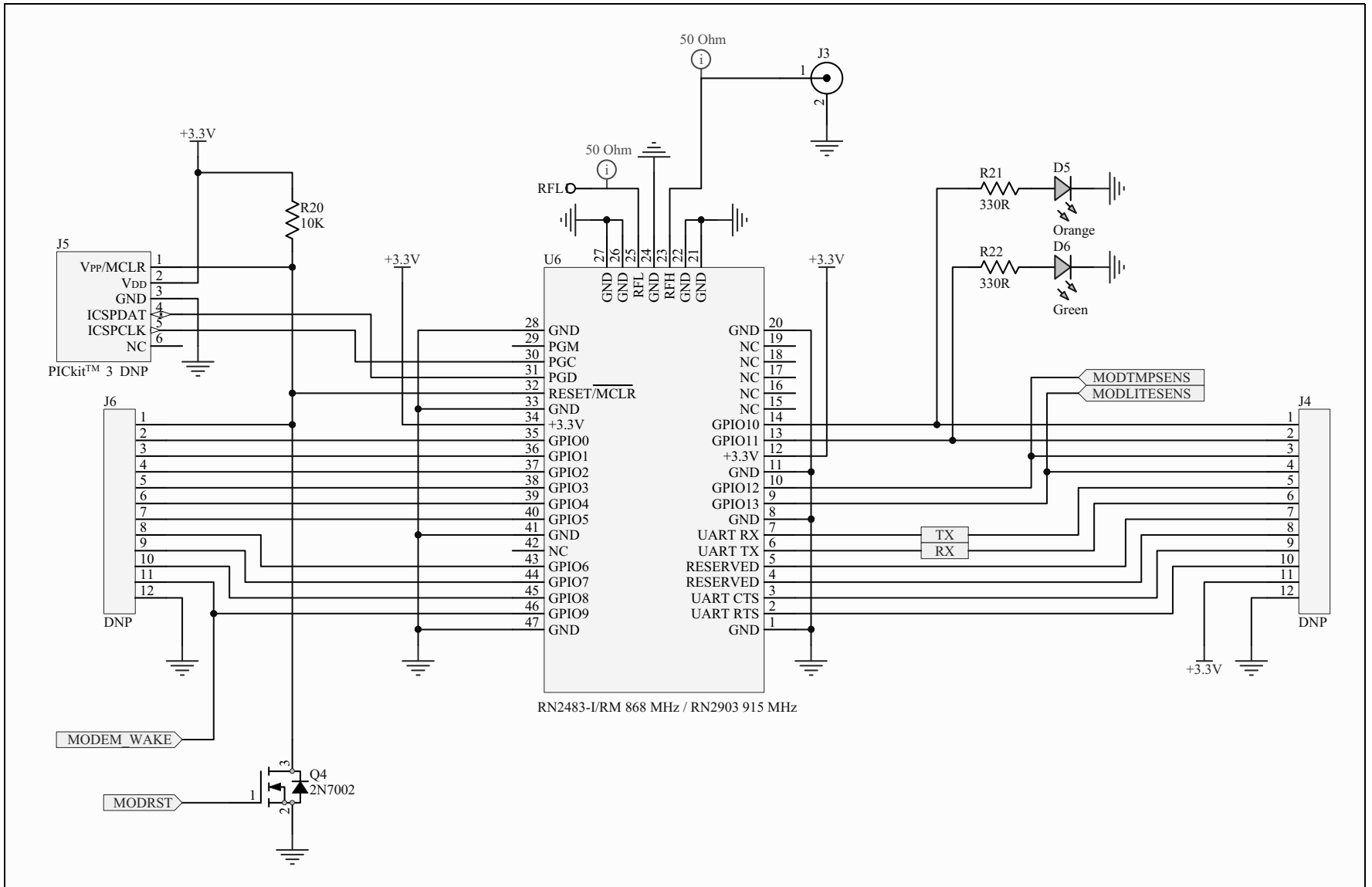

FIGURE A-2: LoRa® MOTE BOARD SCHEMATIC 2



LoRa[®] Mote User's Guide

A.3 BILL OF MATERIALS

TABLE A-1: LoRa[®] MOTE BOARD BILL OF MATERIALS (BOM)

| Quantity | Designator | Description | Manufacturer 1 | Manufacturer Part Number 1 |
|----------|---------------------------------------|--|---------------------------------|----------------------------|
| 1 | B1 | Plastic battery holder, two AAA, series connection | Keystone Electronics | 2468 |
| 2 | C1, C3 | Cap, Ceramic, 4.7 uF, 10V 10% X5R | Kemet | C0603C475K8PACTU |
| 2 | C2, C18 | Cap, Ceramic, 1 uF, 10V X5R | Kemet | C0603C105M8PACTU |
| 1 | C4 | Cap, Ceramic, 10 uF, 10V X5R 10% | TDK Corporation | C1608X5R1A106M |
| 4 | C5, C7, C11, C15 | Cap, Ceramic, 0.1uF, 50V X5R | TDK Corporation | C1608X7R1H104M080AA |
| 1 | C8 | Cap, Ceramic, 2.2 uF, 16V X5R | TDK Corporation | C1608X5R1C225K080AB |
| 8 | C9, C10, C12, C13, C14, C16, C17, C19 | Cap, Ceramic, 1 uF, 16V X5R | TDK Corporation | C1608X5R1C105K080AA |
| 1 | D1 | Diode, Schottky, 20V, 500 mA, SOD123 | ON Semiconductor | MBR0520LT1G |
| 2 | D2, D3 | LED, SMD, RED, 0603 package | Kingbright | APT1608EC |
| 2 | D4, D6 | LED, SMD, GRN, 0603 package | Kingbright | APT1608SGC |
| 1 | D5 | LED, SMD, AMBER, 0603 package | Lite-On Inc | LTST-C190AKT |
| 1 | J1 | Receptacle, Micro USB, Type B, with Solder Tabs, Round Holes | FCI | 10118194-0001LF |
| 1 | J3 | SMA Jack, 50 Ohm, Edge Mount | Samtec | SMA-J-P-H-ST-EM1 |
| 1 | L1 | Inductor, 4.7 uH, Wirewound, 20% SMD 2518 | Taiyo Yuden | CBC2518T4R7M |
| 1 | LCD1 | LCD Display, 1.2 Inch 128 X 32 Dot Matrix, Backlight | EastRising | ERC12832-1 |
| 2 | Q1, Q2 | P-CHAN MOSFET, 20V 2A, Built-In ESD, SOT-363 | Vishay Siliconix | SI1427EDH-T1-GE3 |
| 2 | Q3, Q4 | N-CHAN MOSFET, 60V 115 mA | Fairchild Semiconductor | 2N7002 |
| 1 | Q5 | Sensor, Ambient Light, 630 nM, SMD | Everlight Electronics Co Ltd | ALS-PT19-315C/L177/TR8 |
| 1 | R1 | Res, 1K 1/10W 1% | Panasonic Electronic Components | ERJ-3EKF1001V |
| 1 | R2 | Res, 470 Ohm, 1/10W 1% | Stackpole Electronics Inc. | RMCF0603FT470R |
| 7 | R3, R5, R12, R13, R14, R19, R20 | Res, 10K, 1/10W 1% | Panasonic Electronic Components | ERJ-3EKF1002V |
| 4 | R4, R10, R24, R25 | Res, 0 Ohm, 1/10W | Stackpole Electronics Inc. | RMCF0603ZT0R00 |
| 1 | R6 | Res, 1.69M 1/10W 1% | Vishay Dale | CRCW06031M69FKEA |
| 1 | R8 | Res, 20K 1/10W 1% | Stackpole Electronics Inc. | RMCF0603FT20K0 |
| 2 | R9, R17 | Res, 100K, 1/10W 1% | Stackpole Electronics Inc. | RMCF0603FT100K |
| 1 | R11 | Res, 1M 1/10W 1% | Stackpole Electronics Inc. | RMCF0603FT1M00 |
| 4 | R16, R18, R21, R22 | Res, 330 Ohm, 1/10W 1% | Stackpole Electronics Inc. | RMCF0603FT330R |
| 1 | S1 | Switch, Slide, SPDT, 0.2A, 12V | Copal Electronics Inc | CL-SB-12B-01T |
| 2 | S2, S3 | Switch, Tact, PB MOM SPST-NO, 0.5A, 12V | C&K Components | PTS645SM43SMTR92 LFS |
| 1 | TAPE1 | 3M Foam Tape, Double-Coated, 1.00 X 0.031 X 5yds | 3M (TC) | 1-5-4032W |
| 1 | TAPE2 | Tape, Double-Coated, 1.00 X 0.008 X 5yds | 3M (TC) | 1-5-9088 |
| 1 | U1 | Regulator, LDO, 3.0V, 500 mA, SOT223 | Microchip Technology | MCP1825S-3002E/DB |
| 1 | U2 | Synchronous Boost Regulator with I/O Bypass | Microchip Technology | MCP16252T-I/CH |
| 1 | U3 | USB 8-Bit Flash XLP Microcontroller, 32Kb, UQFN-40 | Microchip Technology | PIC18LF45K50-I/MV |
| 1 | U5 | LP Linear Active Thermistor, SC70-5 | Microchip Technology | MCP9700T-E/LT |
| 1 | U6 | LoRa [®] Module, 868 MHz (915 MHz) | Microchip Technology Inc | RN2483-I/RM (RN2903) |

Appendix B. Legacy Board Schematics and Bill of Materials

B.1 INTRODUCTION

This appendix section provides short descriptions of the Differences between the LoRa[®] Mote Revisions B design discussed in this user's guide, and that of the initial Legacy Mote Design, and the Legacy LoRa[®] Mote board schematics and Bill of Materials (BOM).

- [Differences](#)
- [Board Schematics](#)
- [Bill of Materials](#)

B.2 DIFFERENCES

General:

(New Mote) → (Legacy Mote)

A)

S2 Push Button → S1 Push Button

S3 Push Button → S2 Push Button

B)

Push Button Layout Change

C)

Temperature Sensor Measured by GPIO12 → Measured by PIC via RA2

Light Sensor Measured by GPIO13 → Measured by PIC via RA3

Note: On legacy design the light values are inverted. No/less light results in higher values; while increased/more light will result in lower value.

D)

MODRST → N/A; RN Module RESET pin tied to $\overline{\text{MCLR}}$ & Pull Up (R19) to +3.3 V

(It is RECOMMENDED to have a DEDICATED pin for toggle control of the RN Module RESET pin to prevent power cycle issues which were observed with the Legacy Mote design)

E)

PIC18LF45K50 MCU → PIC18LF25K50

F)

J5 ICSP[™] RN Module Programming Through-Holes → J5 ICSP[™] RN Module Programming Pads

G)

Green/Orange LEDs controlled by GPIO10/GPIO11 Layout Change

H)

PWM driven Backlight LCD (ERC12832-1) → OLED LCD (ER-OLED0.91-3B-3801)

I)

Sharp Ambient Light Sensor (GA1A1S202WP) → Everlight Ambient Light Sensor (ALS-PT19-315C)

LoRa[®] Mote User's Guide

Hardware Description:

The Legacy LoRa[®] Mote design has the following features, as represented in [Figure B-1](#):

1. 868/915 MHz High-Frequency SMA Connector
2. 433 MHz Low-Frequency Antenna Point
3. Module Breakout Header 1
4. Module Breakout Header 2
5. Module Connector
6. SSD1306 (128 x 64) Dot Matrix OLED
7. Module ICSP[™] Programming Pads
8. Mote ICSP Programming Through Hole
9. S1 Switch (Navigation)
10. S2 Switch (Selection)
11. Sharp (GA1A1S202WP) Ambient Light Sensor
12. MCP9700T – Linear Active Thermistor
13. MCP1825S – LDO Regulator
14. PIC18LF25K50 8-bit MCU
15. Alternative Power Supply Through Hole Connectors
16. Descriptive LEDs, (2) Controlled by PIC18, (2) Controlled by Module
17. USB Mini-B Connector
18. Battery Power Switch
19. Website QR Code
20. (2) AAA Battery Pack
21. OLED SSD1306 Ribbon Connector

Legacy Board Schematics and Bill of Materials

FIGURE B-1: LoRa[®] MOTE LEGACY

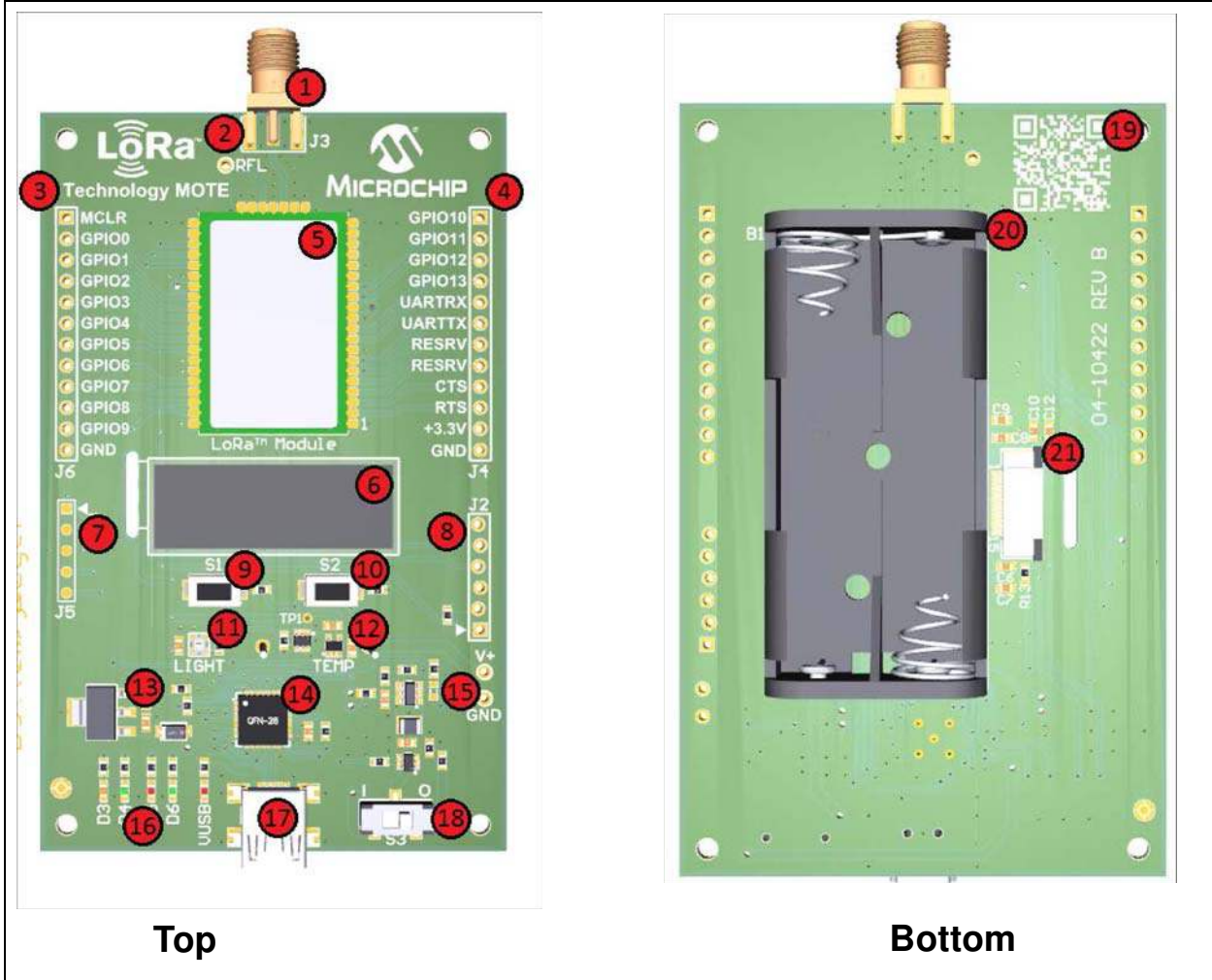

LoRa[®] Mote User's Guide

TABLE B-1: MOTE PIC18LF25K50 USAGE

| Pin Name | Description | Mote Usage |
|-----------------------------|------------------|--|
| General Purpose Pins | | |
| RA0 | USB_DET | USB Power Detection (Digital, Input) |
| RA1 | VBAT | Battery Voltage (Analog, ADC) |
| RA2 | TEMP_SENSE | MCP9700 Thermistor Sensor (Analog, ADC) |
| RA3 | LIGHT_SENSE | GA1A1S202WP Ambient Light Sensor (Analog, ADC) |
| RA4 | VOUT_EN | Boost Regulator Enable (Digital, Output) |
| RA5 | SENSE_PWR | Power Reference Point |
| RA6 | Red LED (D5) | Application Behavior Descriptor (Digital, Output) |
| RA7 | Green LED (D6) | Application Behavior Descriptor (Digital, Output) |
| RB0 | Unused | Unused |
| RB1 | SCK | OLED SPI Clock Reference |
| RB2 | RESET | OLED Manual Reset Control |
| RB3 | SDO | OLED SPI Communication |
| RB4 | CS | OLED Chip-Select |
| RB5 | D/C | OLED Data/Command Select |
| RB6 | PGC | ICSP™ Programmer |
| RB7 | PGD | ICSP Programmer |
| RC0 | S1 Push Button | Application Navigation Controller (Digital, Input) |
| RC1 | S2 Push Button | Application Navigation Controller (Digital, Input) |
| RC2 | MODEM_WAKE | Module Wake Application from Sleep (Digital, Input) [Module GPIO9] |
| RC6 | TX | PIC [®] MCU to Module Communication |
| RC7 | RX | PIC [®] MCU to Module Communication |
| RE3 | MCLR | ICSP™ Programmer |
| Dedicated Pin | | |
| VUSB3V3 | +3.3V | Power Reference |
| D- | DN | USB Communications |
| D+ | DP | USB Communications |
| VDD | +3.3V | Power Source |
| VSS | Ground Reference | Ground Reference |

B.3 BOARD SCHEMATICS

Figure B-2 and Figure B-3 show the legacy board schematics.

FIGURE B-2: LoRa® MOTE LEGACY BOARD SCHEMATIC 1

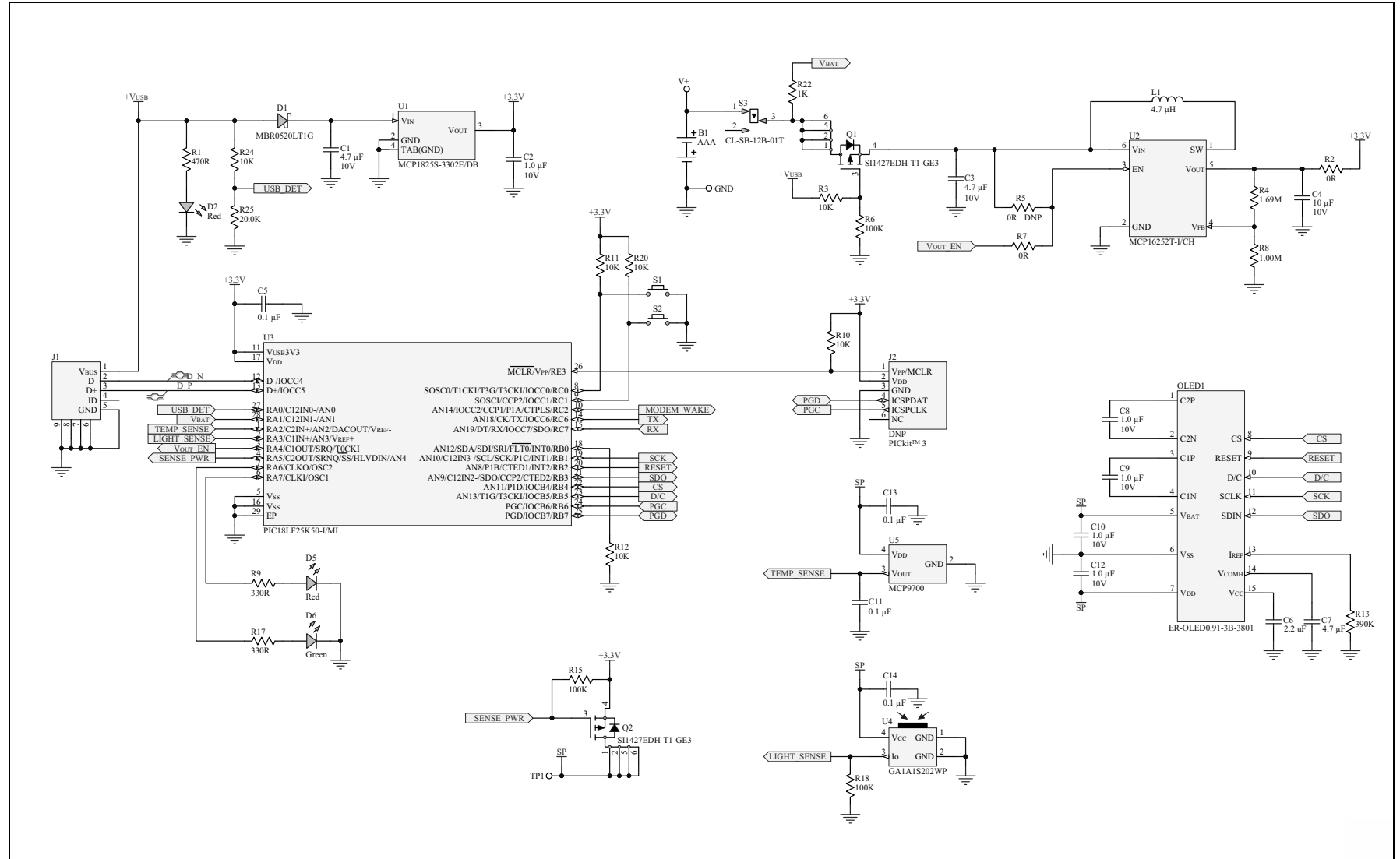
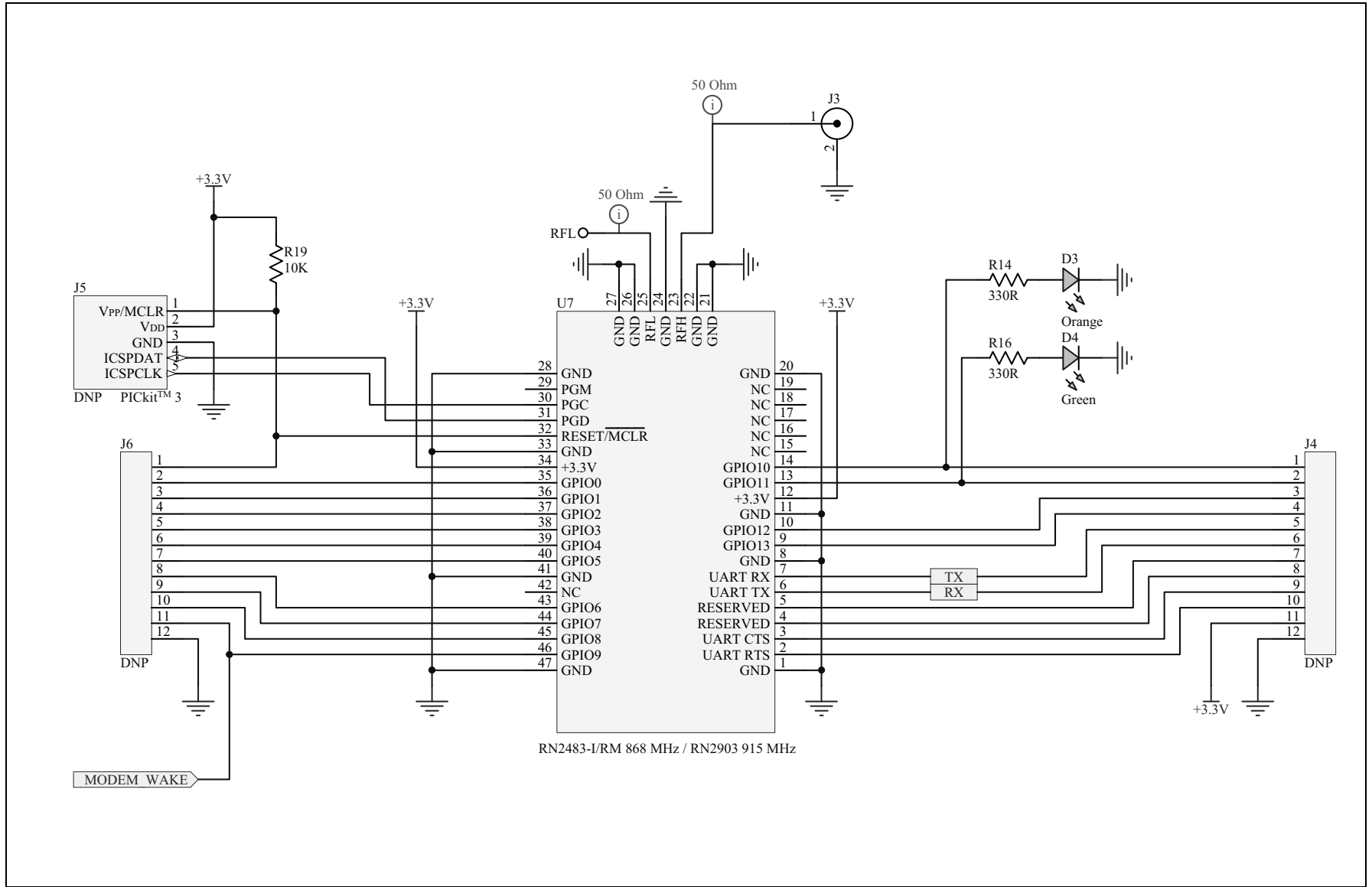

FIGURE B-3: LoRa® MOTE LEGACY BOARD SCHEMATIC 2



B.4 BILL OF MATERIALS

TABLE B-2: BILL OF MATERIALS (BOM)

| Quantity | Designator | Description | Manufacturer 1 | Manufacturer Part Number 1 |
|------------|-----------------------------|--|---------------------------------|----------------------------|
| 1 | B1 | Plastic battery holder, two AAA, series conn, 063 Elev, Tape Mount | Keystone Electronics | 2468 |
| 2 | C1, C3 | Cap, Ceramic, 4.7 uF, 10V 10% X5R | Kemet | C0603C475K8PACTU |
| 5 | C2, C8, C9, C10, C12 | Cap, Ceramic, 1 uF, 10V X5R | Kemet | C0603C105M8PACTU |
| 1 | C4 | Cap, Ceramic, 10 uF, 10V X5R 10% | TDK Corporation | C1608X5R1A106M |
| 4 | C5, C11, C13, C14 | Cap, Ceramic, 0.1 uF, 50V X5R | TDK Corporation | C1608X7R1H104M080AA |
| 1 | C6 | Cap, Ceramic, 2.2 uF, 16V X5R | TDK Corporation | C1608X5R1C225K080AB |
| 1 | C7 | Cap, Ceramic, 4.7 uF, 16V 10% X5R | Taiyo Yuden | EMK107ABJ475KA-T |
| 1 | D1 | Diode, Schottky, 20V, 500 mA, SOD123 | ON Semiconductor | MBR0520LT1G |
| 2 | D2, D5 | LED, SMD, RED, 0603 package | Kingbright | APT1608EC |
| 1 | D3 | LED, SMD, AMBER, 0603 package | Lite-On Inc | LTST-C190AKT |
| 2 | D4, D6 | LED, SMD, GRN, 0603 package | Kingbright | APT1608SGC |
| 1 | J1 | Receptacle, Mini USB, UX60-MB-5ST, Type B | Hirose Electric Co Ltd | UX60-MB-5ST |
| 1 | J3 | SMA Jack, 50 Ohm, Edge Mount | Samtec | SMA-J-P-H-ST-EM1 |
| 1 | L1 | Inductor, 4.7 uH, Wirewound, 20% SMD 2518 | Taiyo Yuden | CBC2518T4R7M |
| 1 | OLED1 | OLED Display Module, SPI, 128 X 32, Blue, with FPC Connector | East Rising | ER-OLED0.91-3B-3801 |
| 2 | Q1, Q2 | P-CHAN MOSFET, 20V 2A, Built-In ESD, SOT-363 | Vishay Siliconix | SI1427EDH-T1-GE3 |
| 1 | R1 | Res, 470 Ohm, 1/10W 1% | Stackpole Electronics Inc | RMCF0603FT470R |
| 4 | R2, R7, R21, R26 | Res, 0 Ohm, 1/10W | Stackpole Electronics Inc | RMCF0603ZT0R00 |
| 6 | R3, R10, R11, R12, R19, R24 | Res, 10K, 1/10W 1% | Panasonic Electronic Components | ERJ-3EKF1002V |
| 1 | R4 | Res, 1.69M 1/10W 1% | Vishay Dale | CRCW06031M69FKEA |
| 3 | R6, R15, R18 | Res, 100K, 1/10W 1% | Stackpole Electronics Inc | RMCF0603FT100K |
| 1 | R8 | Res, 1M 1/10W 1% | Stackpole Electronics Inc | RMCF0603FT1M00 |
| 4 | R9, R14, R16, R17 | Res, 330 Ohm, 1/10W 1% | Stackpole Electronics Inc | RMCF0603FT330R |
| 1 | R13 | Res, 390K, 1/10W 1% | Stackpole Electronics Inc | RMCF0603FT390K |
| 1 | R25 | Res, 20K 1/10W 1% | Stackpole Electronics Inc | RMCF0603FT20K0 |
| 1 | S1 | Switch, Tact, PB MOM SMT, Series TL3302 | E-Switch | TL3302AF180QJ |
| 1 | S2 | Switch, Slide, SPDT, 0.2A, 12V | Copal Electronics Inc | CL-SB-12B-01T |
| 0.9 inches | TAPE1 | 3M Foam Tape, Double-Coated, 1.00 X 0.031 X 5 yds | 3M (TC) | 1-5-4032W |
| 0.4 inches | TAPE2 | Tape, Double-Coated, 1.00 X 0.008 X 5 yds | 3M (TC) | 1-5-9088 |
| 1 | U1 | Regulator, LDO, 3.3V, 500 mA, SOT223 | Microchip Technology | MCP1825S-3302E/DB |
| 1 | U2 | Synchronous Boost Regulator with I/O Bypass | Microchip Technology | MCP16252T-I/CH |
| 1 | U3 | USB 8-Bit Flash Microcontroller, 32Kb, QFN-28 | Microchip Technology | PIC18F25K50-I/ML |

TABLE B-2: BILL OF MATERIALS (BOM) (CONTINUED)

| Quantity | Designator | Description | Manufacturer 1 | Manufacturer Part Number 1 |
|----------|------------|---|--------------------------|----------------------------|
| 1 | U4 | Sensor, Ambient Light, 555 nM, SMD | Sharp Microelectronics | GA1A1S202WP |
| 1 | U5 | LP Linear Active Thermistor, SC70-5 | Microchip Technology | MCP9700T-E/LT |
| 1 | U7 | LoRa [®] Module, 868 MHz (915 MHz) | Microchip Technology Inc | RN2483-I/RM (RN2903) |



MICROCHIP

Worldwide Sales and Service

AMERICAS

Corporate Office

2355 West Chandler Blvd.
Chandler, AZ 85224-6199
Tel: 480-792-7200
Fax: 480-792-7277
Technical Support:
[http://www.microchip.com/
support](http://www.microchip.com/support)

Web Address:
www.microchip.com

Atlanta

Duluth, GA
Tel: 678-957-9614
Fax: 678-957-1455

Austin, TX

Tel: 512-257-3370

Boston

Westborough, MA
Tel: 774-760-0087
Fax: 774-760-0088

Chicago

Itasca, IL
Tel: 630-285-0071
Fax: 630-285-0075

Cleveland

Independence, OH
Tel: 216-447-0464
Fax: 216-447-0643

Dallas

Addison, TX
Tel: 972-818-7423
Fax: 972-818-2924

Detroit

Novi, MI
Tel: 248-848-4000

Houston, TX

Tel: 281-894-5983

Indianapolis

Noblesville, IN
Tel: 317-773-8323
Fax: 317-773-5453

Los Angeles

Mission Viejo, CA
Tel: 949-462-9523
Fax: 949-462-9608

New York, NY

Tel: 631-435-6000

San Jose, CA

Tel: 408-735-9110

Canada - Toronto

Tel: 905-673-0699
Fax: 905-673-6509

ASIA/PACIFIC

Asia Pacific Office

Suites 3707-14, 37th Floor
Tower 6, The Gateway
Harbour City, Kowloon

Hong Kong

Tel: 852-2943-5100
Fax: 852-2401-3431

Australia - Sydney

Tel: 61-2-9868-6733
Fax: 61-2-9868-6755

China - Beijing

Tel: 86-10-8569-7000
Fax: 86-10-8528-2104

China - Chengdu

Tel: 86-28-8665-5511
Fax: 86-28-8665-7889

China - Chongqing

Tel: 86-23-8980-9588
Fax: 86-23-8980-9500

China - Dongguan

Tel: 86-769-8702-9880

China - Hangzhou

Tel: 86-571-8792-8115
Fax: 86-571-8792-8116

China - Hong Kong SAR

Tel: 852-2943-5100
Fax: 852-2401-3431

China - Nanjing

Tel: 86-25-8473-2460
Fax: 86-25-8473-2470

China - Qingdao

Tel: 86-532-8502-7355
Fax: 86-532-8502-7205

China - Shanghai

Tel: 86-21-5407-5533
Fax: 86-21-5407-5066

China - Shenyang

Tel: 86-24-2334-2829
Fax: 86-24-2334-2393

China - Shenzhen

Tel: 86-755-8864-2200
Fax: 86-755-8203-1760

China - Wuhan

Tel: 86-27-5980-5300
Fax: 86-27-5980-5118

China - Xian

Tel: 86-29-8833-7252
Fax: 86-29-8833-7256

ASIA/PACIFIC

China - Xiamen

Tel: 86-592-2388138
Fax: 86-592-2388130

China - Zhuhai

Tel: 86-756-3210040
Fax: 86-756-3210049

India - Bangalore

Tel: 91-80-3090-4444
Fax: 91-80-3090-4123

India - New Delhi

Tel: 91-11-4160-8631
Fax: 91-11-4160-8632

India - Pune

Tel: 91-20-3019-1500

Japan - Osaka

Tel: 81-6-6152-7160
Fax: 81-6-6152-9310

Japan - Tokyo

Tel: 81-3-6880-3770
Fax: 81-3-6880-3771

Korea - Daegu

Tel: 82-53-744-4301
Fax: 82-53-744-4302

Korea - Seoul

Tel: 82-2-554-7200
Fax: 82-2-558-5932 or
82-2-558-5934

Malaysia - Kuala Lumpur

Tel: 60-3-6201-9857
Fax: 60-3-6201-9859

Malaysia - Penang

Tel: 60-4-227-8870
Fax: 60-4-227-4068

Philippines - Manila

Tel: 63-2-634-9065
Fax: 63-2-634-9069

Singapore

Tel: 65-6334-8870
Fax: 65-6334-8850

Taiwan - Hsin Chu

Tel: 886-3-5778-366
Fax: 886-3-5770-955

Taiwan - Kaohsiung

Tel: 886-7-213-7828

Taiwan - Taipei

Tel: 886-2-2508-8600
Fax: 886-2-2508-0102

Thailand - Bangkok

Tel: 66-2-694-1351
Fax: 66-2-694-1350

EUROPE

Austria - Wels

Tel: 43-7242-2244-39
Fax: 43-7242-2244-393

Denmark - Copenhagen

Tel: 45-4450-2828
Fax: 45-4485-2829

France - Paris

Tel: 33-1-69-53-63-20
Fax: 33-1-69-30-90-79

Germany - Dusseldorf

Tel: 49-2129-3766400

Germany - Karlsruhe

Tel: 49-721-625370

Germany - Munich

Tel: 49-89-627-144-0
Fax: 49-89-627-144-44

Italy - Milan

Tel: 39-0331-742611
Fax: 39-0331-466781

Italy - Venice

Tel: 39-049-7625286

Netherlands - Drunen

Tel: 31-416-690399
Fax: 31-416-690340

Poland - Warsaw

Tel: 48-22-3325737

Spain - Madrid

Tel: 34-91-708-08-90
Fax: 34-91-708-08-91

Sweden - Stockholm

Tel: 46-8-5090-4654

UK - Wokingham

Tel: 44-118-921-5800
Fax: 44-118-921-5820

07/14/15