





SPECIFICATIONS

CUSTOMER : _____
MODEL NO. : **GFG144064A-FPFE02**
VERSION : **B**
DATE : **2022.12.21**
CERTIFICATION : **ROHS**

Customer Sign	Approved By	Prepared By	Prepared By
			

晶發科技股份有限公司
GI FAR TECHNOLOGY CO.,LTD.

新北市樹林區東豐街 81 號

No. 81, Dongfeng St, Shulin District, 238034, New Taipei City, Taiwan, R.O.C.

TEL: +886-2-8684-1188 FAX: +886-2-8684-8532



Revision Record

Data(y/m/d)	Ver.	Description	page
2018.08.10	A	Specification released	
2022.12.21	B	更新公司抬頭認證圖示	



CONTENTS

1. SCOPE	-----	4
2. PRODUCT SPECIFICATIONS	-----	4
2.1 General	-----	4
2.2 Mechanical Characteristics	-----	4
2.3 Absolute Maximum Ratings	-----	5
2.4 Electrical Characteristics	-----	5
2.5 Optical Characteristics Absolute maximum ratings	-----	5
2.6 Optical Characteristics	-----	6
2.7 LED Back-light Characteristics	-----	7
3. RELIABILITY	-----	8
4. OPERATING INSTRUCTIONS	-----	9
4.1 Input signal Function	-----	9
4.2 Pin Definition of Parallel/Serial Mode of MPU	-----	10
4.3 Voltage Generator Circuit	-----	11
4.4 Booster Circuit	-----	12
4.5 Timing Diagram	-----	12
4.6 Register Table	-----	16
4.7 Tradition Chinese Character Font Table	-----	17
5. NOTES	-----	24
6. OPERATION PRECAUTIONS	-----	24
7. LCM DIMENSIONS	-----	25
8. Package information	-----	26
Appendix : Inspection Standard		



1. SCOPE

This specification covers the engineering requirements for the GFG144064A-FPFE02 liquid crystal module.

2. PRODUCT SPECIFICATIONS

2.1 General

- 144 × 64 dot matrix LCD
- FSTN , Positive mode LCD panel
- Transflective , Wide temperature type, 6 o'clock
- Back-light : Edge LED , White (AK Length=6mm)
- Multiplexing driving : 1/65duty, 1/9bias
- COG RAIO RA8816N-T
- Interface :Parallel 8Bit (6800&8080) 、 Serial (3Wire& 4Wire)

2.2 Mechanical Characteristics

Item	Characteristic
Dot configuration	144 × 64
Dot dimensions(mm)	0.43 × 0.48
Dot spacing (mm)	0.45 × 0.52
Module dimensions (Horizontal × Vertical × Thickness, mm)	80 × 54 × 9.7
Viewing area (Horizontal × Vertical, mm)	70.7 × 38.8
Active area (Horizontal × Vertical, mm)	64.78 × 33.24
FFC Length(mm)	60mm



2.3 Absolute Maximum Ratings (Without LED back-light)

Item	Symbol	Standard Value		Unit	Remark
		Min.	Max.		
Power Supply Voltage For Logic	V_{DD}	-0.3	+4.0	V	
Power Supply Voltage For LCD	V_{OUT}	-0.3	+14	V	
Input Voltage	V_{IN}	-0.3	+7.0	V	

2.4 Electrical Characteristics (Without LED back-light)

Parameter	Symbol	Min.	Typ.	Max.	Unit	Condition
Operating Voltage	V_{DD}	2.7	3.3	3.6	V	
VOUT Voltage	V_{OUT}	6	--	13.2	V	
Input High Voltage	V_{IH}	$0.8 \times V_{DD}$	--	V_{DD}	V	
Input Low Voltage	V_{IL}	0	--	$0.2 \times V_{DD}$	V	
Output High Voltage	V_{OH}	$0.8 \times V_{DD}$	--	V_{DD}	V	
Output Low Voltage	V_{OL}	0	--	$0.2 \times V_{DD}$	V	
Built-in Reference Voltage	V_{IREF}	2.08	2.1	2.12	V	Test by C/P tester
Input Leakage Current	I_{IL}	-1	--	+1	μA	$V_{IN} = V_{SS} \sim V_{DD}$
Oscillator Frequency	F_{CL}	80	100	120	KHz	
Operating Mode Current (Normal Mode Current)	I_{DD}	0.2	--	1.1	mA	Min.:*1 Max.:*2
Sleep Mode Current	I_{SLP}	--	0.2	3	μA	

2.5 Optical Characteristics Absolute maximum ratings

Item	Symbol	Rating	Unit
Operating temperature range	Top	-20~70	$^{\circ}C$
Storage temperature range	Tst	-30~80	$^{\circ}C$



2.6 Optical Characteristics

1/65duty, 1/9bias, Vop=10.0V, Ta=25°C

Item	Symbol	Conditions	Min.	Typ.	Max	Reference
Driving voltage	Vop		9.7	10.0	10.3	
Viewing angle	θ	$C \geq 2.0, \phi = 0^\circ$	30°	-	-	Notes 1 & 2
Contrast	C	$\theta = 5^\circ, \phi = 0^\circ$	2	4	-	Note 3
Response time(rise)	ton	$\theta = 5^\circ, \phi = 0^\circ$	-	200ms	-	Note 4
Response time(fall)	toff	$\theta = 5^\circ, \phi = 0^\circ$	-	240ms	-	Note 4

Note 1: Definition of angles θ and ϕ

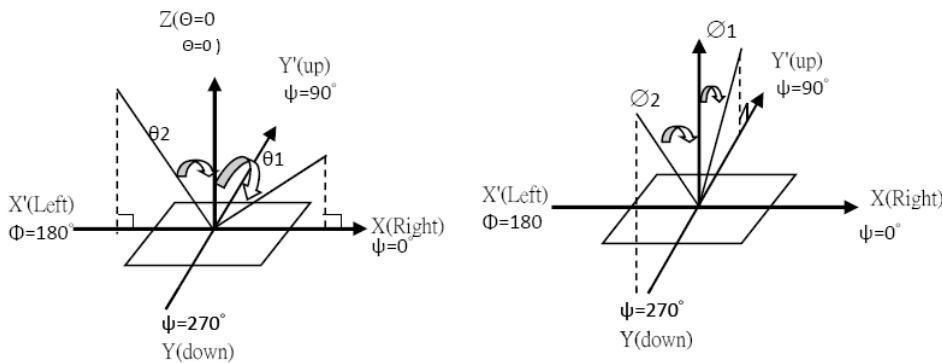

Note 2: Definition of viewing angles θ_1 and θ_2

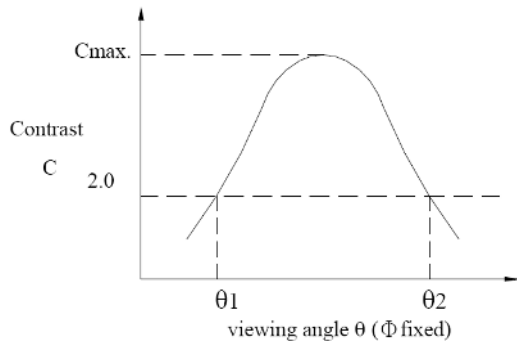

Note : Optimum viewing angle with the naked eye and viewing angle θ at Cmax. Above are not always the same

Note 3: Definition of contrast C

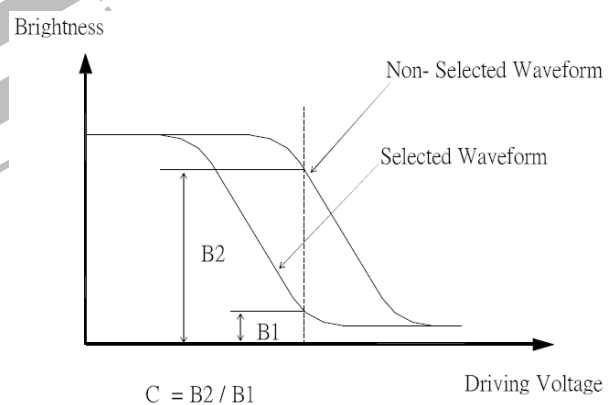

Note 4: Definition of response time

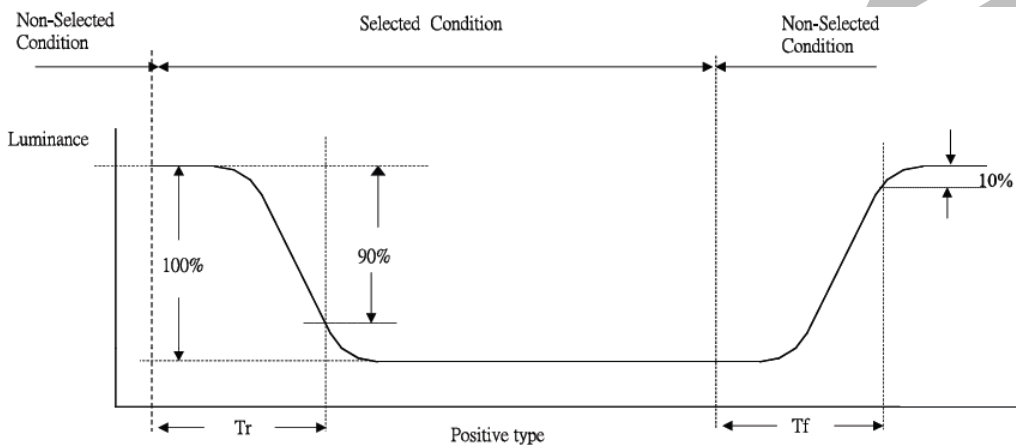



2.7 LED Back-light Characteristics

2.7.1 Electrical / optical specifications

Ta = 25°C

Item	Symbol	Condition	Min.	Typ.	Max.	Unit
Forward voltage	V _f	I _f =80mA, White	2.7	3.0	3.3	V
LED *Luminous Intensity	I _v	I _f =80mA, White	450	600	--	Cd/m ²
Chromaticity Coordinate	x	I _f =80mA, White	0.26	0.29	0.32	
	y		0.27	0.31	0.34	
Reverse Current	I _R	V _R =5V, White	--	--	80	uA
Luminous Uniformity	ΔL _v	I _f =80mA, White	70			%

Note: * Measured at the bare LED back-light unit.

2.7.2 LED Maximum Operating Range

Item	Symbol	White	Unit
Power Dissipation	P _{AD}	256	mW
Forward Current	I _F	100	mA
Reverse Voltage	V _R	5	V



3. RELIABILITY

NO.	ITEM	CONDITION		STANDARD	NOTE
1	High Temp. Storage	80°C	120 hrs	Appearance Without defect	
2	Low Temp. Storage	-30°C	120 hrs	Appearance Without defect	
3	High Temp. & High Humi. Storage	40°C 90% RH	120 hrs	Appearance Without defect	
4	High Temp. Operating Display	70°C	120 hrs	Appearance Without defect	
5	Low Temp. Operating Display	-20°C	120 hrs	Appearance Without defect	
6	Thermal Shock	-20°C, 30min. → 70°C, 30min. ↑ (1cycle)		Appearance Without defect	10 cycles

** Dissipation current, contrast and display functions

** Polarizing filter deterioration, other appearance defects

** The function test shall be conducted after 4hours storage at the normal temperature and humidity after remove from the test chamber.



4. OPERATING INSTRUCTIONS

4.1 Input signal Function

NO.	Symbol	Function
1	REST	RESET
2	INT	This is an interrupt output for MPU. Active low ◦
3	P/S	Parallel/Serial Select P/S = 0 → The MPU interface is serial mode (Default). See the setting of DB[7:6]. P/S = 1 → The MPU interface is parallel mode.
4	C86	MPU Select C86 = 0 → The MPU interface is 8080 series. C86 = 1 → The MPU interface is 6800 series (Default). This pin must be kept high for serial mode.
5	/CS	Chip Select This is chip enable for RA8816N. This pin must be kept high for serial mode.
6	RS	When use 8080 series interface, this is Data or Command signal. When D/C is "0", means Register Cycle (or Command Cycle). When D/C is "1", means Data Access Cycle (Data Cycle). When use 6800 series interface, this is the RS signal. When RS is "0", means Register Cycle and "1" means Data Access Cycle. This pin must be kept high for serial mode.
7	/WR or R/W	Write Control or Read-Write Control When use 8080 series interface, /WR is the write signal and active low. When use 6800 series interface, this pin is R/W, active high for read cycle and active low for write cycle. This pin must be kept high for 3 or 4-wires serial mode.
8	/RD or EN	Read Control or Enable When use 8080 series interface, RD is the read signal and active low. When use 6800 series interface, EN is the Enable signal and active high. This pin must be kept high for 3 or 4-wires serial mode.
9	DB0	Data Bus
10	DB1	When MPU uses parallel mode and 8-bit interface then all of the DB[7:0] are valid. When uses 4-bit interface then only DB[3:0] are valid, and DB[7:4] have to be kept floating.
11	DB2	
12	DB3	When P/S is "0", then the interface between MPU and RA8816N is SerialMode. The pins DB[7:6] (SMOD[1:0]) are used to select which serial mode:
13	DB4	SMOD : Serial Mode
14	DB5	0 0 : Reserved.
15	DB6	0 1 : 3-Wire, SCK, SDA, CS are used.
16	DB7	1 0 : 4-Wire, SCK, SDA, RS, CS are used. 1 1 : 4-Wire, SCK, SDO, SDI, CS are used. In serial mode, all of the related signals are defined by DB[3:0]: SCK (DB0) : Serial Clock. SDA (DB1) : Bi-direction Mode Serial Data. SDO (DB1) : Data Out. RS (DB2) : Memory/Register Cycle Select. SDI (DB2) : Serial Data In. CS (DB3) : Chip Select, active low.
17	VDD	VDD Power
18	GND	Ground



19	VREF	Reference Voltage Input This is the external reference voltage input when the internal one is disabled.
20~24	V4~V0	Voltage Source of LCD Driver The relationship of the power is $V_{OUT} > V_0 \geq V_1 \geq V_2 \geq V_3 \geq V_4 \geq V_{SS}$
25	C1P	These are used to connect a capacitor for internal Booster.
26	C1M	These are used to connect a capacitor for internal Booster.
27	C2P	These are used to connect a capacitor for internal Booster.
28	C2M	These are used to connect a capacitor for internal Booster.
29	CP3	These are used to connect a capacitor for internal Booster.
30	VLCD	Booster Output

4.2 Pin Definition of Parallel/Serial Mode of MPU

Pin Name	I/O	Parallel Mode				Serial Mode		
		8080		6800		3-Wire	4-Wire (A-Type)	4-Wire (B-Type)
		8Bit	4Bit	8Bit	4Bit			
DB7	I/O	DB7	--*1	DB7	--	0	1	1
DB6	I/O	DB6	--	DB6	--	1	0	1
DB5	I/O	DB5	--	DB5	--	--	--	--
DB4	I/O	DB4	--	DB4	--	--	--	--
DB3	I/O	DB3	DB3	DB3	DB3	\overline{CS}	\overline{CS}	\overline{CS}
DB2	I/O	DB2	DB2	DB2	DB2	--	RS	SDI
DB1	I/O	DB1	DB1	DB1	DB1	SDA	SDA	SDO
DB0	I/O	DB0	DB0	DB0	DB0	SCK	SCK	SCK
\overline{RD} , EN	I	\overline{RD}	\overline{RD}	EN	EN	1*2	1*2	1*2
\overline{WR} , R/ \overline{W}	I	\overline{WR}	\overline{WR}	R/ \overline{W}	R/ \overline{W}	1*2	1*2	1*2
D/ \overline{C} , RS	I	D/ \overline{C}	D/ \overline{C}	RS	RS	1*2	1*2	1*2
\overline{CS}	I	\overline{CS}	\overline{CS}	\overline{CS}	\overline{CS}	1	1	1
C86	I	0	0	1	1	1	1	1
BIT4	I	0	1	0	1	1	1	1
P/ \overline{S}	I	1	1	1	1	0	0	0

Note1 : "--" means the pin is not used and kept floating (NC).

Note2 : In serial mode, the unused parallel pins have to be connected to high (VDD).





4.3 Voltage Generator Circuit

SMOD		Serial Interface Mode
0	1	3-Wires. Use signals SCK, SDA and \overline{CS} .
1	0	4-Wires (A-Type). Use signals SCK, SDA, RS and \overline{CS} .
1	1	4-Wires (B-Type). Use signals SCK, SDO, SDI and \overline{CS} .

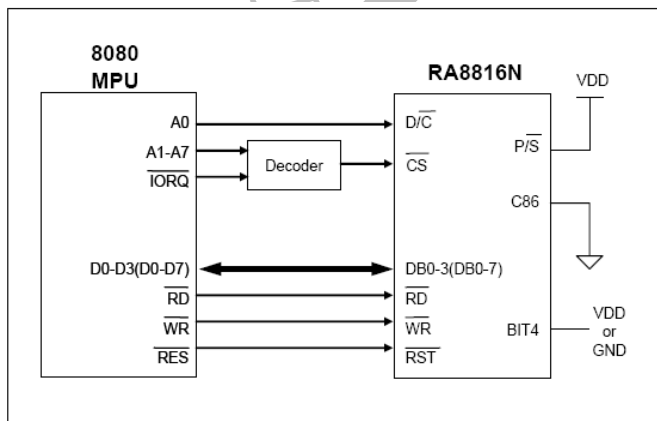

8080 (4/8-Bit) MPU Interface

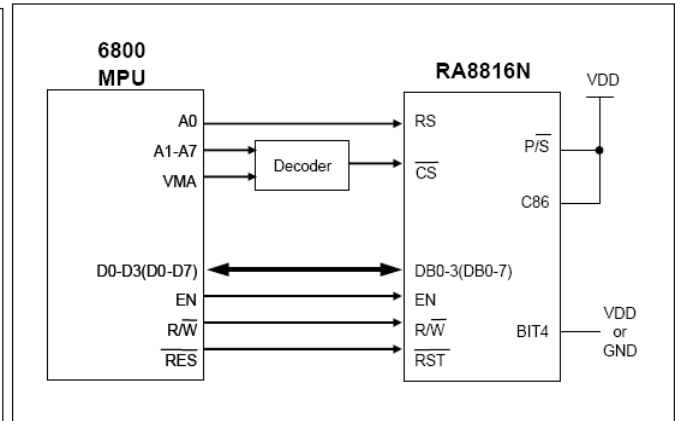

6800 (4/8-Bit) MPU Interface

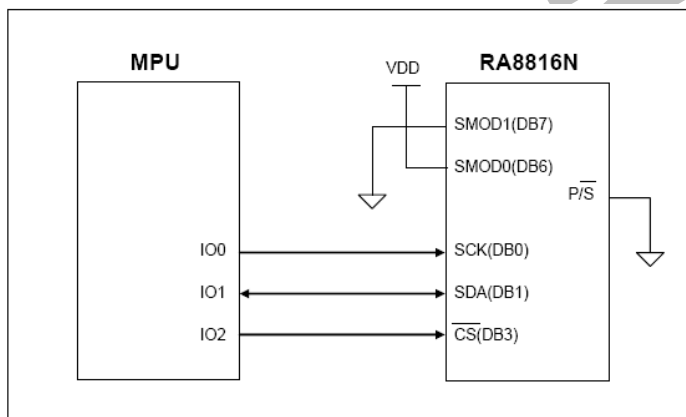

3-Wires MPU Interface

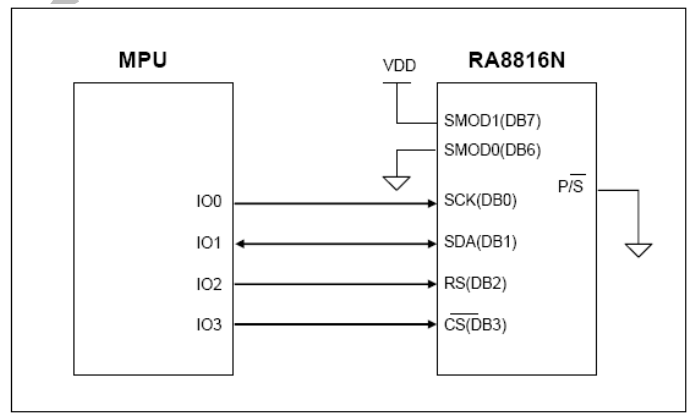

4-Wires (A-Type) MPU Interface

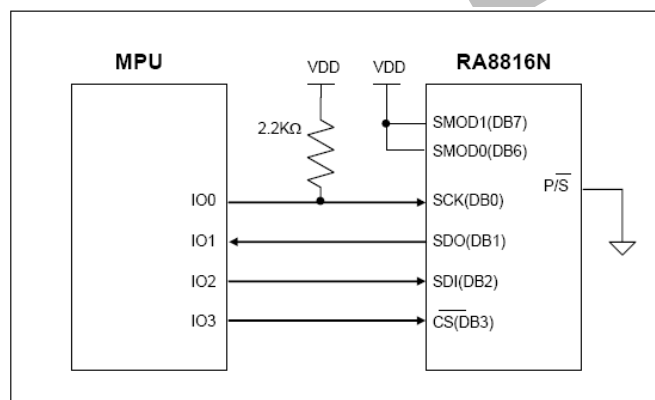

4-Wires (B-Type) MPU Interface



4.4 Booster Circuit

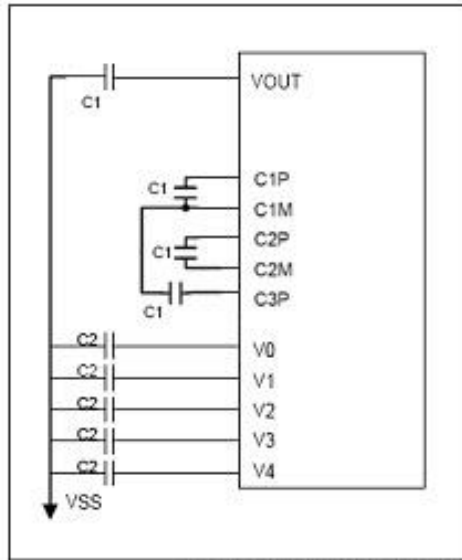

Internal VOUT ($4 \times VDD$)

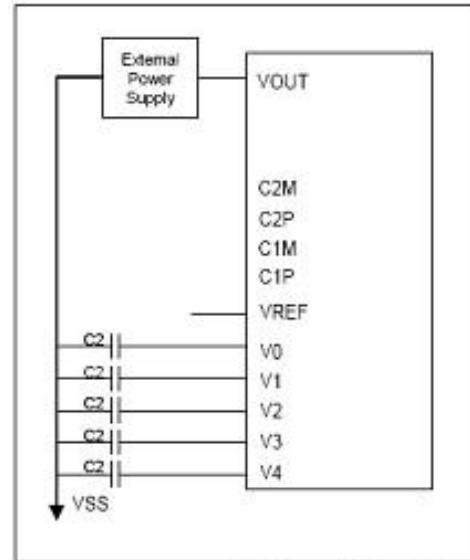

External VOUT

Note: The capacitor value of C1 is 1uF and C2 is 1uF.

4.5 Timing Diagram

4.5.1 Parallel Interface 6800 MPU Timing

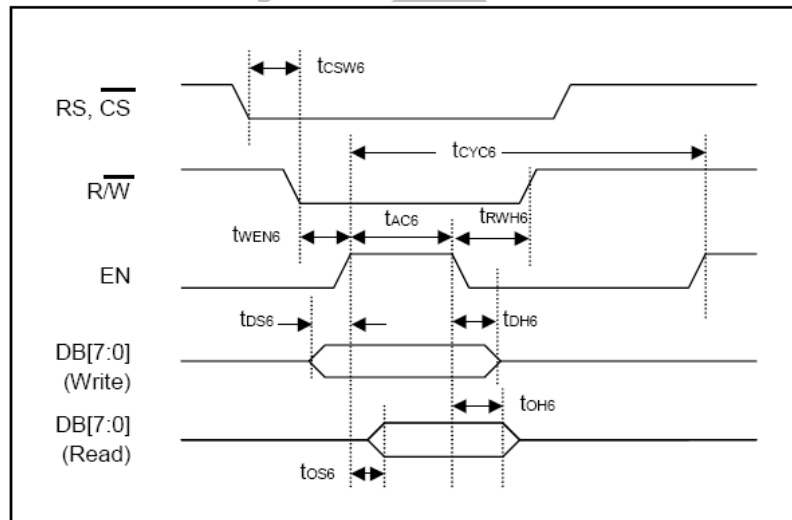

Item	Signal	Symbol	Condition	Rating		Unit
				Min.	Max.	
Address Setup Time	RS, \overline{CS}	t_{csW6}		0	--	ns
Read/Write Setup Time	R/\overline{W}	t_{wEN6}		10	--	
Read/Write Hold Time		t_{rWH6}		10	--	
Enable Access Time	EN	t_{AC6}	Command Cycle	90	--	
Access Cycle Time		t_{CYC6}	Data Cycle	200	--	
Write Data Setup Time	DB[7:0]	t_{DS6}		10	--	
Write Data Hold Time		t_{DH6}		10	--	
Read Data Access Time		t_{OS6}		30	50	
Read Data Hold Time		t_{OH6}		10	--	



4.5.2 Parallel Interface 8080 MPU Timing

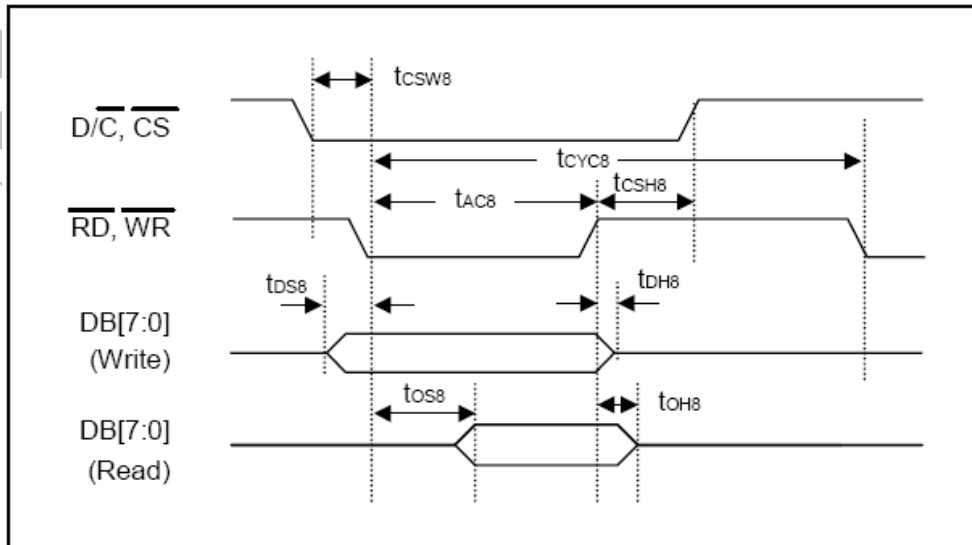

Item	Signal	Symbol	Condition	Rating		Unit
				Min.	Max.	
Address Setup Time	$\overline{RS}, \overline{CS}$	t_{CSW8}		10	--	ns
Address Hold Time		t_{CSH8}		10	--	
Read/Write Access Time	$\overline{RD}, \overline{WR}$	t_{AC8}		90	--	
Access Cycle Time		t_{CYC8}	Command Cycle	200	--	
			Data Cycle	400	--	
Write Data Setup Time	DB[7:0]	t_{DS8}		10	--	
Write Data Hold Time		t_{DH8}		10	--	
Read Data Setup Time		t_{OS8}		30	50	
Read Data Hold Time		t_{OH8}		10	--	



4.5.3 Serial Interface 3-Wire Timing

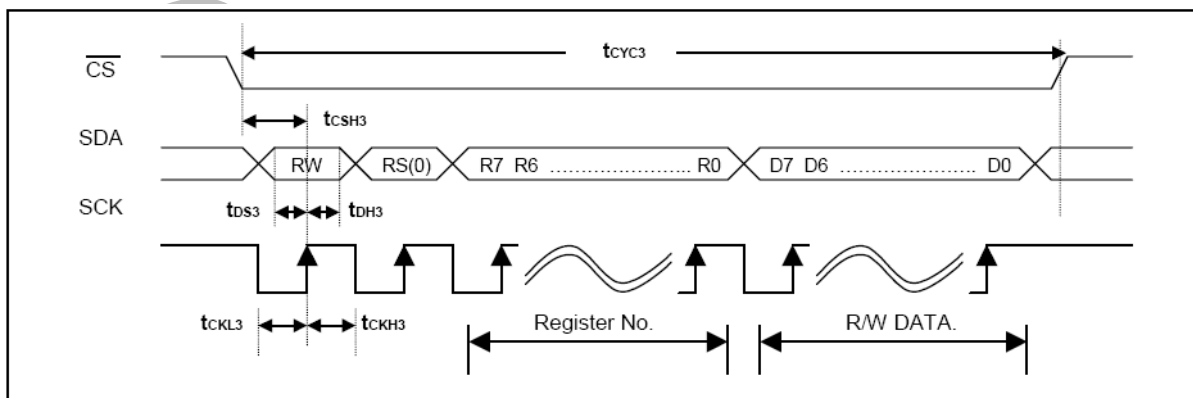

Item	Signal	Symbol	Condition	Rating		Unit
				Min.	Max.	
Access Time	$\overline{\text{CS}}$	t_{CYC3}		3.6	--	μs
$\overline{\text{CS}}$ Setup Time	$\overline{\text{CS}}$	t_{CSH3}		20	--	ns
Clock Low Pulse Width	SCK	t_{CKL3}		100	--	
Clock High Pulse Width		t_{CKH3}		100	--	
Data Setup Time	SDA	t_{DS3}		20	--	
Data Hold Time		t_{DH3}		10	--	

4.5.4 Serial Interface 4-Wire(A-Type) Timing

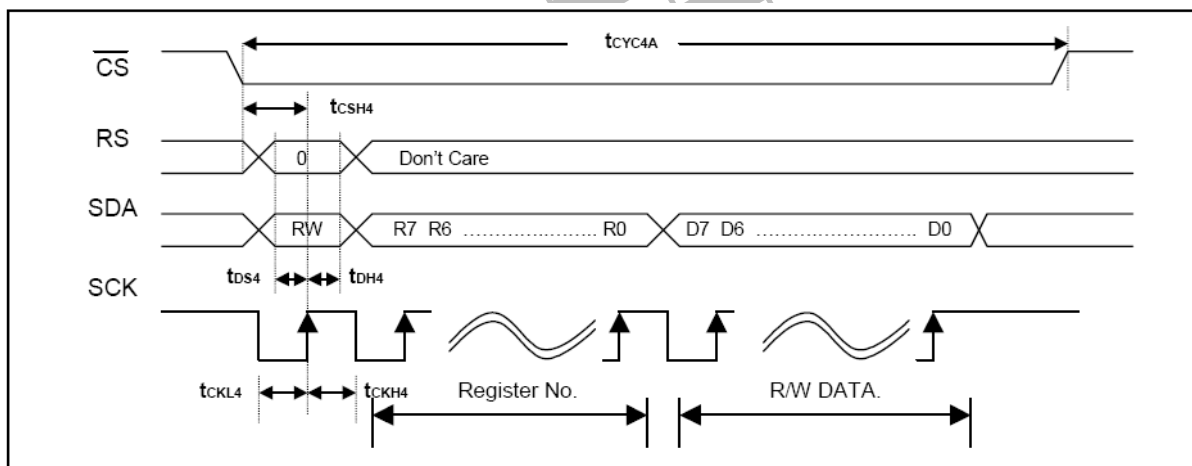

Item	Signal	Symbol	Condition	Rating		Unit
				Min.	Max.	
Access Time	$\overline{\text{CS}}$	t_{CYC4A}		3.4	--	μs
$\overline{\text{CS}}$ Setup Time	$\overline{\text{CS}}$	t_{CSH4}		20	--	ns
Clock Low Pulse Width	SCK	t_{CKL4}		100	--	
Clock High Pulse Width		t_{CKH4}		100	--	
Data Setup Time	SDA, RS	t_{DS4}		20	--	
Data Hold Time		t_{DH4}		10	--	



4.5.5 Serial Interface 4-Wire(B-Type) Timing

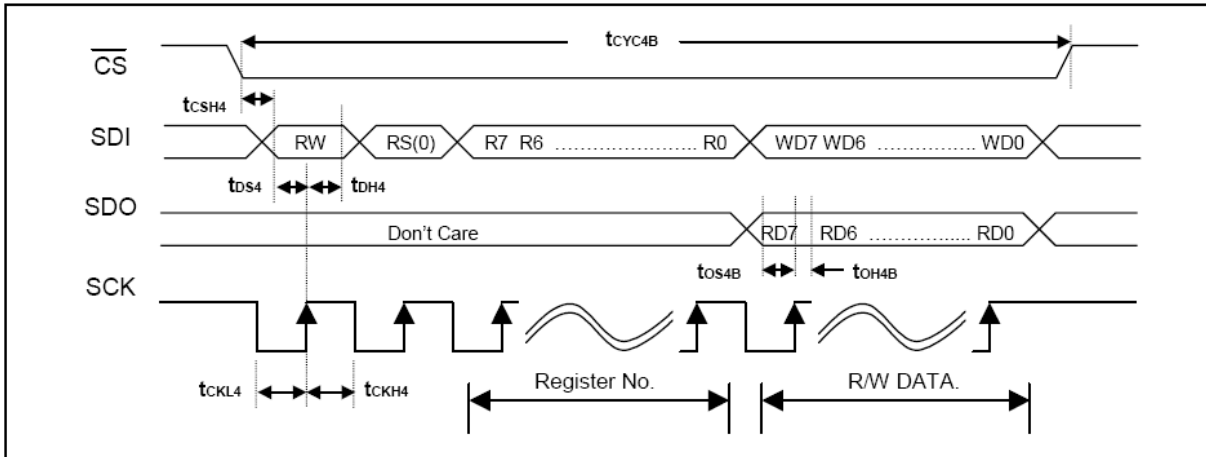

Item	Signal	Symbol	Condition	Rating		Unit
				Min.	Max.	
Access Time	\overline{CS}	t_{CYC4B}		3.6	--	μs
\overline{CS} Setup Time	\overline{CS}	t_{CSH4}		20	--	ns
Clock Low Pulse Width	SCK	t_{CKL4}		100	--	
Clock High Pulse Width		t_{CKH4}		100	--	
Data Write Setup Time	SDI	t_{DS4}		20	--	
Data Write Hold Time		t_{DH4}		10	--	
Data Read Setup Time	SDO	t_{OS4B}		20	--	
Data Read Hold Time		t_{OH4B}		10	--	

4.5.6 Reset Interface Reset Timing

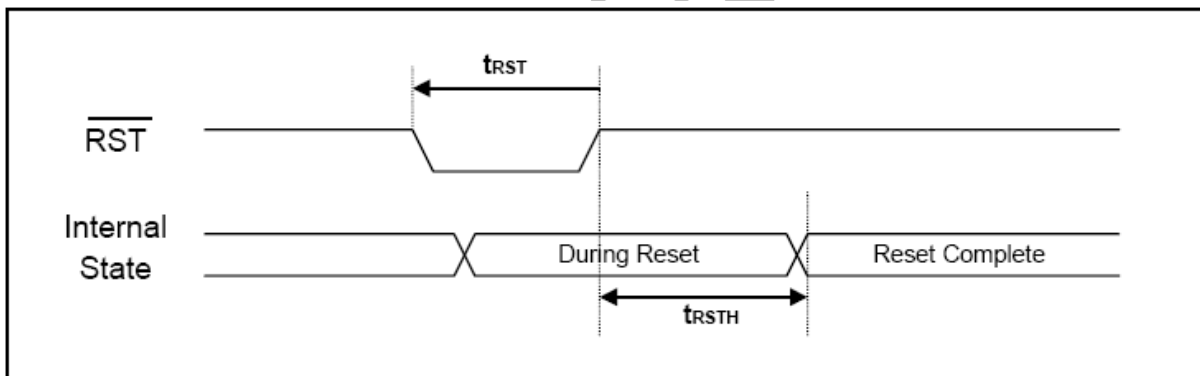

Item	Signal	Symbol	Condition	Rating		Unit
				Min.	Max.	
Reset Pulse Width	\overline{RST}	t_{rST}		5	--	ms
Reset Complete Hold Time	\overline{RST}	t_{rSTH}	$F_{CL} = 100KHz$ (Internal RC Oscillator)	5	--	ms



4.6 Register Table

ID	Name	D7	D6	D5	D4	D3	D2	D1	D0	Description
0	DWFR	B/C	--	NW5	NW4	NW3	NW2	NW1	NW0	Wave Form Select
1	PWRR	SRST	MCLR	--	IO_IEN	KWK	IOWK	DOFF_Z	SLP	Power Control
2	SYSR	LS3	LS2	LS1	LS0	FONT1	FONT0	RS1	RS0	System Setting
3	MWMR	BMOD1	BMOD0	BIEN	ASCS	BOLD	INV	MD1	MD0	Memory Mode
4	CURCR	H3	H2	H1	H0	--	BLK	CR	CUR_E N	Cursor Control
5	X-CUR	--	--	X5	X4	X3	X2	X1	X0	Cursor X Position
6	Y-CUR	--	Y6	Y5	Y4	Y3	Y2	Y1	Y0	Cursor Y Position
7	KEYR	KSB	KDB1	KDB0	KSTB_S EL	K_AUTO	IRE	KF1/ KSTB1	KF0/ KSTB0	Key-scan Control
	KSDR	SIRQ	KSTB1	KSTB0	KSD4	KSD3	KSD2	KSD1	KSD0	Key-scan Data
SIRQ		AKD6	AKD5	AKD4	AKD3	AKD2	AKD1	AKD0		
8	SWSXR	--	--	--	SSX4	SSX3	SSX2	SSX1	SSX0	X-Scroll Start
9	SWSYR	--	--	SSY5	SSY4	SSY3	SSY2	SSY1	SSY0	Y-Scroll Start
A	SWRXR	--	--	--	SRX4	SRX3	SRX2	SRX1	SRX0	X-Scroll Range
B	SWRYR	PINV	--	SRY5	SRY4	SRY3	SRY2	SRY1	SRY0	Y-Scroll Range
C	SCOR	SL7	SL6	SL5/SR5	SL4/SR4	SL3/SR3	SL2/SR2	SL1/SR1	SL0/SR0	Scroll Unit
D	ASCR	SPD3	SPD2	SPD1	SPD0	STP3	STP2	STP1	STP0	Auto Scroll Control
E	SCCR	SCR_IM D1	SCR_IM D0	SCR_M D	SBUF	SCR_DI R1	SCR_DI R0	SCR_IN TEN	AUTO_S CR	Scroll Control
F	ISR	BF	--	--	--	IO_I	SCR_I	KI	BI	Interrupt Status
10	CSTR	BR2	BR1	BR0	CT4	CT3	CT2	CT1	CT0	Contrast
11	DRCR_A	BOFF	EN_R	EN_G	ROFF	IDIR	--	CDIR	SDIR	Driver Control
12	DRCR_B	CK_BS1	CK_BS0	RR2	RR1	RR0	IRS	--	--	Driver Control
13	BLTR	BLK_EN	PBK_EN	--	INV	BLT3	BLT2	BLT1	BLT0	Blink Setting
14	IODR	OE7	OE6	OE5	OE4	OE3	OE2	OE1	OE0	I/O Port Direction
15	IODAR	IOD7	IOD6	IOD5	IOD4	IOD3	IOD2	IOD1	IOD0	I/O Port Data
17	CGMI	--	--	--	--	--	UMI2	UMI1	UMI0	Create Font Select
18	CGMD	CGMD7	CGMD6	CGMD5	CGMD4	CGMD3	CGMD2	CGMD1	CGMD0	Create Font Data
19	MISR	--	--	--	--	--	--	--	EOR	Misc Register



4.7 Tradition Chinese Character Font Table

A1	0	1	2	3	4	5	6	7	8	9	A	B	C	D	E	F
4		,	、	。	·	•	;	:	?	!	:	…	…	,	、	.
5		·	:	:	?	!		-		-		—	{	~	()
6		˘	{	}	—	—	[]	—	—	【	】	—	—	《	》
7		˘	<	>	˘	˘	「	」	—	—	『	』	—	—	()
A	?			[]	‘	”	“	”	”	”	”	”	#	&	*
B	※	§	#	○	●	△	▲	◎	☆	★	◇	◆	□	■	▽	▼
C	®	%	-	—	—	—	—	—	—	—	—	—	—	#	&	*
D	-	x	÷	±	√	<	>	=	≤	≥	≠	∞	≡	+	-	
E	<	>	=	~	∩	U	⊥	∠	∟	△	log	ln	∫	∫	∴	∴
F	♀	♂	⊕	⊙	↑	↓	←	→	↖	↗	↘	↙			/	?

A4	0	1	2	3	4	5	6	7	8	9	A	B	C	D	E	F
4	一	乙	丁	七	乃	九	了	二	人	儿	入	八	几	刀	刁	力
5	匕	十	卜	又	三	下	丈	上	丫	丸	凡	久	么	也	乞	于
6	亡	兀	刃	勻	千	叉	口	土	士	夕	大	女	子	孑	寸	
7	小	尢	尸	山	川	工	己	己	巳	巾	干	井	弋	弓	才	?
A	?	丑	丐	不	中	丰	丹	之	尹	予	云	井	互	五	亢	仁
B	什	竹	仆	仇	仍	今	介	仄	元	允	内	六	兮	公	亢	凶
C	分	切	刈	勻	勾	勿	化	匹	午	升	卅	卞	厄	友	及	反
D	壬	天	夫	太	夭	孔	少	尤	尺	屯	巴	幻	廿	弔	引	心
E	戈	戶	手	扎	支	文	斗	斤	方	日	日	月	木	欠	止	歹
F	毋	比	毛	氏	水	火	爪	父	爻	片	牙	牛	犬	王	丙	?

A2	0	1	2	3	4	5	6	7	8	9	A	B	C	D	E	F
4	\	/	\	\$	¥	₹	¢	£	%	@	°	°	\$	%	@	mil
5	mm	cm	km	KM	m²	mg	kg	cc	°	尅	尅	尅	尅	尅	尅	尅
6	尅	尅	尅	尅	尅	尅	尅	尅	尅	尅	尅	尅	尅	尅	尅	尅
7	■	+	+	+	+	+	+	+	+	+	+	+	+	+	+	?
A	?	˘	˘	—	—	—	—	—	—	—	—	—	—	—	—	0
B	1	2	3	4	5	6	7	8	9	I	II	III	IV	V	VI	VII
C	VIII	IX	X													A
D	B	C	D	E	F	G	H	I	J	K	L	M	N	O	P	Q
E	R	S	T	U	V	W	X	Y	Z	a	b	c	d	e	f	g
F	h	i	j	k	l	m	n	o	p	q	r	s	t	u	v	?

A5	0	1	2	3	4	5	6	7	8	9	A	B	C	D	E	F
4	世	丕	且	丘	主	乍	乏	乎	以	付	仔	仕	他	仗	代	令
5	仙	仞	充	兄	冉	冊	冬	凹	出	凸	刊	加	功	包	匆	北
6	匪	仞	半	卉	卡	占	卯	危	去	可	古	右	召	叮	叩	叨
7	叨	司	匡	叫	另	只	史	叱	台	句	叭	叻	四	囚	外	?
A		央	失	奴	奶	孕	它	尼	巨	巧	左	市	布	平	幼	弁
B	弘	弗	必	戊	打	扔	扒	扑	斥	且	朮	本	未	未	札	正
C	母	民	氏	永	汁	汀	汜	犯	玄	玉	瓜	瓦	甘	生	用	甩
D	田	由	甲	申	疋	白	皮	皿	目	矛	矢	石	示	禾	穴	立
E	丞	丟	兵	兵	乚	互	交	亦	亥	仿	伉	伙	伊	伏	伍	伐
F	休	伏	仲	伴	任	仰	佻	份	企	佞	光	兕	兆	先	全	?

A3	0	1	2	3	4	5	6	7	8	9	A	B	C	D	E	F
4	w	x	y	z	A	B	Γ	Δ	E	Z	H	Θ	I	K	Λ	M
5	N	Ξ	O	Π	P	Σ	T	Υ	Φ	X	Ψ	Ω	α	β	γ	δ
6	ε	ζ	η	θ	ι	κ	λ	μ	ν	ξ	ο	π	ρ	σ	τ	υ
7	φ	χ	φ	ω	々	々	∏	∏	々	去	ろ	々	《	巧	厂	?
A	?	ㄣ	ㄣ	ㄣ	ㄣ	ㄣ	ㄣ	ㄣ	ㄣ	ㄣ	ㄣ	ㄣ	ㄣ	ㄣ	ㄣ	ㄣ
B	ㄣ	ㄣ	ㄣ	ㄣ	ㄣ	ㄣ	ㄣ	ㄣ	ㄣ	ㄣ	ㄣ	ㄣ	ㄣ	ㄣ	ㄣ	ㄣ
C																
D																
E																
F																

A6	0	1	2	3	4	5	6	7	8	9	A	B	C	D	E	F
4	共	再	冰	列	刑	划	刎	劣	匈	匡	匠	印	危	吉	吏	
5	同	吊	吐	吁	时	各	向	名	合	吃	后	叻	吒	因	回	囟
6	圳	地	在	圭	圻	圻	夙	多	夷	夸	妄	奸	妃	好	她	
7	如	妁	字	存	宇	守	宅	安	寺	尖	屹	州	帆	并	年	?
A	?	式	弛	忙	付	戎	戎	戎	戎	扣	扛	托	收	早	旨	旬
B	旭	曲	曳	有	朽	朴	朱	朵	次	此	死	氛	汝	汗	汗	江
C	池	汐	汕	污	汛	汎	汎	灰	牵	牝	百	竹	米	糸	缶	羊
D	羽	老	考	而	耒	耳	聿	肉	肋	肌	臣	自	至	白	舌	舛
E	舟	艮	色	艾	虫	血	行	衣	西	阡	串	亨	位	住	佇	佗
F	倭	伴	佛	何	估	佐	佑	伽	伺	伸	佃	估	似	但	侖	?



A7	0	1	2	3	4	5	6	7	8	9	A	B	C	D	E	F
4	作	你	伯	低	伶	余	徇	佈	佚	兌	克	免	兵	治	冷	別
5	判	利	刪	創	劫	助	努	劬	匪	即	卵	吝	吮	吞	吾	否
6	呎	吧	呆	呢	吳	呈	呂	君	吩	告	吹	吻	吸	吮	吵	吶
7	吠	吼	呀	吱	含	吟	听	囟	困	囹	圉	坊	坑	址	坍	?
A	?	均	坎	圾	坐	坏	圻	壯	夾	妝	妒	妨	妞	妣	妙	妖
B	妍	姪	妓	妊	妥	孝	孜	孚	幸	完	宋	宏	尅	局	屁	尿
C	尾	岐	岑	岔	岌	巫	希	序	庇	床	廷	弄	弟	彤	形	彷彿
D	役	忘	忌	志	忍	忱	快	忸	忸	戒	我	抄	抗	抖	技	扶
E	抉	扭	把	扼	找	批	扳	抒	扯	折	扮	投	抓	抑	拔	改
F	攻	攸	旱	更	東	李	杏	材	村	杜	杖	杞	杉	杆	杠	?

AA	0	1	2	3	4	5	6	7	8	9	A	B	C	D	E	F
4	昇	服	朋	杭	枋	枕	東	果	杳	杷	枇	枝	林	杯	杰	板
5	枉	松	析	杵	枚	料	杼	杪	杲	欣	武	歧	歿	氓	氛	泣
6	注	泳	沱	泌	泥	河	沽	沾	沼	波	沫	法	泓	沸	泄	油
7	況	沮	泗	泗	決	沿	治	泡	泛	泊	沫	浪	沏	泐	?	?
A	?	炕	炎	炒	炊	炙	爬	爭	爸	版	牧	物	狀	狎	狙	狗
B	狐	玩	珏	玫	玫	玥	眈	疙	疚	的	孟	盲	直	知	矽	
C	社	祀	祁	秉	穉	空	穹	筮	糾	罔	羌	芊	者	肺	肥	肢
D	肱	股	肫	肩	肴	肪	肯	臥	與	舍	芳	芝	芙	芭	芽	芟
E	芹	花	芬	芥	苾	芸	苳	芟	芟	芟	芟	芟	芟	芟	芟	芟
F	返	近	邵	邱	邱	邱	邱	邱	邱	邱	邱	邱	邱	邱	邱	邱

A8	0	1	2	3	4	5	6	7	8	9	A	B	C	D	E	F
4	杓	棠	步	每	求	汞	沙	沁	沈	沉	沅	沛	汪	決	沐	汰
5	沌	汨	冲	沒	汽	沃	汲	汾	汙	沆	汶	沔	沔	沔	沂	灶
6	灼	災	灸	牢	牡	牠	狄	狂	玖	甬	甫	男	甸	皂	盯	矣
7	私	秀	秃	究	系	罕	肖	育	肝	肘	肱	肚	育	良	芒	?
A	?	芋	苟	見	角	言	谷	豆	豕	貝	赤	走	足	身	車	辛
B	辰	迂	迪	迅	迄	巡	邑	邢	邪	邦	那	酉	采	里	防	阮
C	阱	阪	阮	並	乖	乳	事	些	亞	享	京	佯	依	侍	佳	使
D	佬	供	例	來	侃	佰	併	侈	佩	佻	侖	侑	侑	侑	倭	兔
E	兒	兕	兩	具	其	典	冽	函	刻	券	刷	刺	到	刮	制	制
F	効	勳	卒	協	卓	卑	卦	卷	卸	卸	取	叔	受	味	呵	?

AB	0	1	2	3	4	5	6	7	8	9	A	B	C	D	E	F
4	陂	隹	雨	青	非	亟	亭	亮	信	侵	侯	便	俠	備	俏	保
5	促	侶	俘	俟	俊	俗	侮	俐	俄	係	俚	俚	俚	俚	俚	俚
6	青	冠	剌	剌	削	前	刺	刺	則	勇	勉	勃	勁	匍	南	卻
7	厚	叛	咬	哀	咨	哎	哉	咸	嘆	咳	哇	晒	咽	咪	品	?
A	?	哄	哈	咯	咫	咱	咻	咻	咻	咻	咻	咻	咻	咻	咻	咻
B	城	垮	垓	奕	契	奏	奎	奐	姜	姘	姿	姣	姨	娃	姥	姪
C	姚	姦	威	姻	孩	宣	宦	室	客	宥	封	屎	屏	屍	屋	峙
D	峒	巷	帝	帥	帶	幽	庠	度	建	弈	弭	彥	很	待	徊	律
E	徇	後	徇	怒	思	怠	急	怎	怨	恍	恰	恨	恢	恆	恃	恬
F	恫	恪	恤	扁	拜	挖	按	拼	拭	持	拮	拽	指	拱	擗	?

A9	0	1	2	3	4	5	6	7	8	9	A	B	C	D	E	F
4	咖	呷	咕	咀	呻	呷	咄	咒	咆	呼	咐	呱	呶	和	咚	呢
5	周	咋	命	咎	固	垃	坳	坪	坳	坳	坦	坤	坼	夜	奉	奇
6	奈	奄	奔	妾	妻	委	妹	妮	姑	姆	姐	姍	始	姓	姊	妯
7	妳	奴	婢	孟	孤	季	宗	定	官	宜	宙	宛	尙	屈	居	?
A	?	屨	岷	岡	岸	岩	岫	岱	岳	帶	帶	帖	帕	帛	帛	幸
B	庚	店	府	底	庖	延	弦	弧	弩	往	征	佛	彼	忝	忠	忽
C	念	忿	快	征	怯	怵	怖	怪	怕	怡	性	惘	佛	但	或	戕
D	房	戾	所	承	拉	拌	拄	扞	拂	抹	拒	招	披	拓	拔	拋
E	拈	揆	抽	押	拐	拙	拇	拍	抵	拚	抱	拘	拖	拗	拆	抬
F	拎	放	斧	於	旺	昔	易	昌	昆	昂	明	昀	昏	昕	昊	?

AC	0	1	2	3	4	5	6	7	8	9	A	B	C	D	E	F
4	拯	括	拾	拴	挑	挂	政	故	斫	施	既	春	昭	映	味	是
5	星	昨	昱	聆	曷	柿	染	柱	柔	某	東	架	枯	柵	樞	柯
6	柄	柑	枊	柚	查	枸	柏	柞	柳	柞	柞	柞	柞	柞	柞	柞
7	殆	段	毒	毗	氟	泉	洋	洲	洪	流	津	洳	洳	洳	洳	洳
A	?	活	洽	派	洵	洛	泵	涸	涸	洳	洳	洳	洳	洳	洳	洳
B	爲	炳	炬	炯	炭	炸	炮	炤	爰	牲	牯	牯	狩	狼	狡	玷
C	珊	玻	玲	珍	珀	玳	甚	甬	畏	界	畎	畎	疫	疤	疥	疥
D	疣	癩	皆	皇	飯	盈	盆	盃	盃	盃	盃	盃	盃	盃	盃	盃
E	眇	矜	矜	矜	矜	矜	矜	矜	矜	矜	矜	矜	矜	矜	矜	矜
F	突	竿	竿	籽	紂	紅	紀	紂	紂	紂	紂	紂	紂	紂	紂	紂



晶發科技股份有限公司

GI FAR TECHNOLOGY CO., LTD.

No. 81, Dongfeng St, Shulin District, 238034, New Taipei City, Taiwan, R.O.C.



AD	0	1	2	3	4	5	6	7	8	9	A	B	C	D	E	F
4	耐	耍	崙	耶	胖	胥	胚	胃	胃	背	胡	胛	胎	胞	胤	臍
5	致	舛	芋	范	茅	苜	苜	苦	茄	若	茂	茱	苒	苗	英	茁
6	苜	苔	苑	苞	芩	苟	茛	虻	虻	虻	虻	虻	虻	虻	虻	虻
7	計	訂	訃	貞	負	赴	赴	赴	赴	赴	赴	赴	赴	赴	赴	赴
A	?	迭	迫	迤	迤	郊	郎	郁	郜	魯	酏	重	門	限	陋	陌
B	降	面	革	韋	韭	音	頁	風	飛	食	首	香	乘	毫	信	倍
C	傲	俯	倦	倥	倥	倥	倥	倥	倥	倥	倥	倥	倥	倥	倥	倥
D	倨	俱	倡	個	候	倘	俳	修	倭	倪	俾	倫	倉	兼	冤	冥
E	豕	凍	凌	准	凋	剖	剌	剔	剛	剝	匪	卿	原	晉	叟	哨
F	唐	唱	嗜	亨	哥	哲	唆	哺	唔	哩	哭	員	唉	哮喘	哪	?

B0	0	1	2	3	4	5	6	7	8	9	A	B	C	D	E	F
4	虔	蚊	蚪	蚪	蚤	蚩	蚌	蚣	蚣	蚣	衰	衰	衰	袂	衽	祇
5	訐	討	訐	訐	訐	訐	訐	訐	訐	訐	訐	訐	訐	訐	訐	訐
6	躬	軒	軻	軻	軻	軻	軻	軻	軻	軻	軻	軻	軻	軻	軻	軻
7	郡	郝	郢	酒	配	酌	釘	針	針	針	釜	針	閃	院	陣	陡
A	?	陞	陝	除	陞	陸	隻	飢	馬	骨	高	鬥	鬲	鬼	乾	僭
B	偽	停	假	偃	偃	偃	健	偶	偃	偃	偃	偵	側	偷	偏	條
C	儂	儂	兜	冕	鳳	剪	副	勒	務	勸	勸	勸	勸	勸	勸	勸
D	匾	參	曼	喬	帕	啦	啜	啜	啜	啜	啜	啜	啜	啜	啜	啜
E	啤	唸	售	啜	啜	啜	啜	啜	啜	啜	啜	啜	啜	啜	啜	啜
F	埠	埠	基	堂	堵	執	培	夠	奢	娶	婁	婉	婦	焚	婀	?

AE	0	1	2	3	4	5	6	7	8	9	A	B	C	D	E	F
4	哦	唧	唇	哽	唏	圃	圉	埂	埔	埋	埃	堉	夏	套	奘	奚
5	娑	娘	娜	娟	娛	媪	姬	娠	娣	媿	娥	媿	媿	孫	冠	幸
6	害	家	宴	宮	宵	容	宸	射	肩	展	屐	峭	峽	峻	峪	峨
7	峰	島	坎	峴	差	席	師	庫	庭	座	弱	徒	徑	徐	恙	?
A	?	恣	恥	恐	怒	恭	恩	息	悄	悟	悚	悍	悔	悌	悅	悖
B	扇	拳	擊	拿	拊	挾	振	捕	拊	拊	捏	捉	挺	捐	挽	挪
C	挫	挨	捍	捌	效	糶	料	旁	旅	時	晉	晏	晃	晒	晌	暄
D	晁	書	朔	朕	朗	校	核	案	框	框	根	桂	桔	栩	梳	栗
E	桌	桑	栽	柴	桐	桀	格	桃	株	桅	桂	移	朽	殊	殉	殷
F	氣	氣	氮	氮	氮	泰	浪	涕	涓	涓	浦	浸	海	浙	涓	?

B1	0	1	2	3	4	5	6	7	8	9	A	B	C	D	E	F
4	娼	婢	婚	婆	姨	孰	寇	寅	寄	寂	宿	密	尉	專	將	屠
5	屨	扉	崇	崆	崎	嶠	崖	崢	崑	崩	崔	崙	崙	崙	崙	崙
6	常	帶	帳	帷	康	庸	庶	庵	庚	張	強	彗	彬	彩	影	得
7	徙	從	徘徊	御	徠	徇	患	患	患	患	患	患	患	患	患	患
A	?	情	悻	悻	悻	悻	悻	悻	悻	悻	悻	悻	悻	悻	悻	悻
B	掠	控	捲	掖	探	接	捷	捧	掘	措	搵	掩	掉	掃	掛	捫
C	推	掄	授	掙	採	掬	排	掏	掀	揜	捨	捺	敝	救	救	救
D	教	敗	啓	敏	敘	救	敵	斜	斛	斬	族	旋	旌	旌	晝	晚
E	晤	晨	晦	晞	曹	勗	望	梁	梯	梢	梓	梵	桿	桶	樞	梧
F	梗	械	槌	槩	棧	柳	梅	樞	條	梨	梟	椀	棧	欲	殺	?

AF	0	1	2	3	4	5	6	7	8	9	A	B	C	D	E	F
4	湮	涉	浮	浚	浴	浩	涌	忍	浹	濕	淝	泮	烱	烘	烤	烙
5	烈	烏	爹	特	狼	狹	狽	狽	玃	玃	玃	玃	玃	玃	玃	玃
6	畔	畝	畜	畜	留	疾	病	症	疲	瘡	疽	疹	癩	疽	皯	皯
7	胞	益	盍	盍	眩	真	眠	眨	矩	砵	砵	砵	砵	砵	砵	砵
A	?	砥	砥	砥	砵	砲	祕	祐	祠	崇	祖	神	祝	祇	祚	枰
B	株	秧	租	秦	秩	秘	窄	窈	站	筇	笑	粉	紡	紗	紋	紊
C	素	索	純	紐	紕	級	紕	納	紙	紛	缺	罟	羔	翅	翁	耆
D	耘	耕	耙	耗	耽	耽	耽	耽	耽	耽	耽	耽	耽	耽	耽	耽
E	能	脊	胼	胼	臭	臬	昏	舐	航	舫	舫	般	芻	茫	荒	荔
F	荆	茸	荐	草	茵	茵	苕	茲	茹	茶	茗	荀	菜	茨	荃	?

B2	0	1	2	3	4	5	6	7	8	9	A	B	C	D	E	F
4	毫	毳	氲	涎	涼	淳	涼	液	淡	淌	淤	添	淺	清	淇	淋
5	涯	淑	澗	淞	淹	涸	混	淵	淅	淒	渚	涵	淚	淫	淘	淪
6	深	淮	淨	滑	溜	涪	涑	涑	淦	烹	焉	焊	烽	烯	爽	牽
7	犁	猜	猛	獾	獾	獾	獾	獾	球	理	現	琺	瓠	瓠	瓠	瓠
A	?	盜	甜	產	略	哇	畢	異	疏	痔	痕	疵	痊	痲	咬	盃
B	盒	盛	眷	眾	眼	眶	眸	眺	疏	硃	硃	硃	祥	票	祭	移
C	窳	筮	笨	笛	第	符	笙	笞	笞	笞	粒	粗	粕	絆	絃	統
D	紹	縛	細	細	紳	組	累	終	繼	絨	絨	差	羚	翌	翎	習
E	耜	聊	聆	脯	膊	腎	脫	脩	脰	脈	春	舵	舩	船	船	莎
F	莞	莘	莘	莢	莖	莽	莫	莖	莊	莓	莉	莠	荷	荻	茶	?



晶發科技股份有限公司 GI FAR TECHNOLOGY CO., LTD.

No. 81, Dongfeng St, Shulin District, 238034, New Taipei City, Taiwan, R.O.C.



B3	0	1	2	3	4	5	6	7	8	9	A	B	C	D	E	F
4	莆	莧	處	彪	蛇	蛙	蚘	蚰	蚋	蛆	蛋	蚱	蚯	蛉	術	衰
5	袈	被	袒	袖	袍	袋	覓	規	訪	訝	訣	訥	許	設	訟	訛
6	訖	鼓	豚	販	責	貫	貨	貪	貧	赧	赦	趾	跌	軛	軟	這
7	逍	通	逗	連	速	逝	逐	逕	逞	造	透	逢	逖	逛	途	?
A	?	部	郭	都	酈	野	釵	釵	鈞	釧	釧	釧	閉	陪	陵	陳
B	陸	陰	陴	陶	陷	陬	雀	雪	雩	章	竟	頂	頃	魚	烏	鹵
C	鹿	麥	麻	傢	傍	傅	備	傑	傀	佺	傘	倣	最	凱	割	剗
D	創	剩	勞	勝	助	博	厥	畜	喀	喧	啼	喊	喝	喘	喂	喜
E	喪	唄	唻	喋	喃	喳	單	喟	唾	啣	喚	喻	喬	嘔	啾	喉
F	喫	喙	圍	堯	堪	場	堤	堰	報	堡	堧	壺	壺	奠	?	

B6	0	1	2	3	4	5	6	7	8	9	A	B	C	D	E	F
4	詔	詛	詐	詆	訴	診	訶	詖	象	貂	貯	貼	貳	貽	賁	費
5	賀	貴	買	貶	貨	越	超	趁	跬	距	跋	跚	跑	跌	跛	
6	跲	軻	軸	軼	辜	速	逵	週	逸	進	透	鄂	郵	鄉	鄧	酣
7	酥	量	鈔	鈕	鈣	鈉	鈞	鈇	鈇	鈇	閔	閩	開	閑	?	
A	?	間	閒	閱	隊	階	隋	陽	隅	隆	隍	隍	隍	雁	雅	雄
B	集	雇	雯	雲	韌	項	順	須	飡	飧	飯	飽	飲	飭	馮	馭
C	黃	黍	黑	亂	傭	債	傲	傳	僅	傾	催	傷	傻	德	僂	剿
D	割	剗	募	勦	勤	勢	勤	匯	嗟	噉	噉	噉	噉	嗎	嗜	嗑
E	嗣	啞	噁	鳴	喻	嗅	噲	噉	噉	噉	噉	噉	噉	噉	噉	噉
F	塔	填	塌	塆	塊	塢	塢	塢	塢	奧	嫁	嫉	嫌	媾	媽	媪

B4	0	1	2	3	4	5	6	7	8	9	A	B	C	D	E	F
4	婷	媚	媚	媒	媛	媯	孳	孳	孳	寒	富	寓	寐	尊	尋	就
5	嵐	巖	嵇	巽	幅	帽	幘	幘	幘	幾	廊	廁	廂	廂	弼	彭
6	循	徨	惑	惡	悲	悶	惠	愜	悒	悒	悒	悒	悒	悒	悒	悒
7	復	惶	愉	愀	愀	載	扉	掣	掌	描	揀	措	揉	揆	揆	?
A	?	插	揣	提	握	揖	揭	揮	捶	援	揪	換	捩	揚	揩	做
B	敦	敢	散	斑	斐	斯	普	晰	晴	晶	景	暑	智	晾	曷	曾
C	替	期	朝	棺	棕	棠	棘	棗	椅	棟	棵	森	棧	棹	棒	棲
D	棗	棋	棍	植	椒	椎	棉	棚	楮	菜	款	欺	欽	殘	殖	殼
E	毯	氦	氫	氫	港	游	游	游	游	游	游	游	游	游	游	游
F	湘	渤	湖	漣	渭	渦	湯	渴	湍	渺	測	湃	淪	淪	滋	?

B7	0	1	2	3	4	5	6	7	8	9	A	B	C	D	E	F
4	媳	嫂	媿	媿	嵩	嵯	幌	幹	廉	廈	弒	彙	傍	微	愚	慈
5	感	想	愛	惹	愁	愈	慎	慌	慄	慄	愠	愠	愠	愠	愠	愠
6	戡	戡	搓	搾	搞	搪	搭	搽	搬	搏	搜	搔	損	搶	搖	搗
7	構	敬	斟	新	暗	暉	暇	暈	暖	暄	暄	暄	會	榔	業	?
A	?	楚	楷	楠	楔	極	椰	概	楊	楨	楫	楞	楓	楹	榆	棟
B	楣	梛	歇	歲	毀	殿	毓	璉	溢	溯	滓	溶	滂	源	溝	瀆
C	滅	溥	溥	溥	溥	溥	溥	溥	溥	溥	溥	溥	溥	溥	溥	溥
D	煩	煤	煉	照	煜	煬	煦	煌	煥	煥	煥	煥	煥	煥	煥	煥
E	獅	猿	猓	瑯	瑚	瑕	瑟	瑞	瑁	瑁	瑁	瑁	瑁	瑁	瑁	瑁
F	痰	瘁	癩	癩	癩	癩	癩	癩	癩	癩	癩	癩	癩	癩	癩	癩

B5	0	1	2	3	4	5	6	7	8	9	A	B	C	D	E	F
4	溉	渙	洹	潛	涓	涓	湏	湏	湏	湏	湏	湏	湏	湏	湏	湏
5	牌	犄	犀	猶	猥	猴	猩	玳	琪	琳	琢	琥	琵琶	琴	琯	
6	琛	琦	琨	甥	甦	畫	番	痢	痛	痣	瘰	痘	痞	瘰	登	發
7	皖	皓	皴	盜	暍	短	硝	硬	硯	稍	稈	程	稅	稀	窘	?
A	?	窗	窗	童	竣	等	策	筆	筐	筒	答	筍	筋	筏	筑	栗
B	粥	絞	結	絨	絕	紫	絮	絲	絡	給	絢	經	絳	善	翔	翕
C	臺	聒	肅	腕	腔	腋	腋	腎	脹	腆	脾	脍	腓	腓	舒	舜
D	菩	萃	菸	萍	菠	菅	萋	菁	華	菱	菴	著	萊	菰	萌	菌
E	菽	菲	菊	莢	葵	荀	菜	萵	菹	菹	菹	菹	菹	菹	菹	菹
F	蛤	蚰	蛙	街	裁	裂	袂	單	視	註	詠	評	詞	証	詰	?

B8	0	1	2	3	4	5	6	7	8	9	A	B	C	D	E	F
4	睹	翠	睬	睜	睜	睜	睜	矮	碎	碰	碗	碗	碗	碗	碗	碗
5	確	確	確	確	確	確	確	確	確	確	確	確	確	確	確	確
6	節	筠	筵	筵	梁	粳	粳	粳	經	絹	網	網	網	網	網	網
7	署	義	羨	群	聖	聘	肆	肆	肆	肆	肆	肆	肆	肆	肆	肆
A	?	腹	腺	腦	鼻	艇	蒂	葷	落	萱	葵	葦	葫	葉	葬	葛
B	萼	萼	萼	萼	萼	萼	萼	萼	萼	萼	萼	萼	萼	萼	萼	萼
C	蛻	蜂	蜃	蜃	蜃	蜃	蜃	蜃	蜃	蜃	蜃	蜃	蜃	蜃	蜃	蜃
D	規	解	詔	該	詳	試	詩	詰	誇	詼	詼	詼	詼	詼	詼	詼
E	詮	詔	詹	詔	訾	訾	訾	訾	訾	訾	訾	訾	訾	訾	訾	訾
F	賅	跡	跟	跨	路	跳	跳	跳	跳	跳	跳	跳	跳	跳	跳	跳



晶發科技股份有限公司

GI FAR TECHNOLOGY CO., LTD.

No. 81, Dongfeng St, Shulin District, 238034, New Taipei City, Taiwan, R.O.C.



B9	0	1	2	3	4	5	6	7	8	9	A	B	C	D	E	F
4	辟	農	運	遊	道	遂	達	逼	遑	遐	遇	遇	過	遍	遑	逾
5	遁	鄒	鄒	酬	酩	酩	釉	鈷	鉗	鉗	鉗	鉗	鉗	鉗	鉗	鉗
6	鉑	鈴	鉸	鉸	鉸	鉸	鉸	鉸	鉸	鉸	鉸	鉸	鉸	鉸	鉸	鉸
7	雷	電	電	零	靖	靴	靴	預	頑	頓	頌	頌	頌	飼	飴	?
A	?	飽	飾	馳	馱	馴	鬚	鳩	兜	鼎	鼓	鼠	僧	僮	僥	僥
B	僭	僚	僕	像	僑	僱	僱	閒	競	竟	劃	厖	厭	嗾	嗾	嗾
C	嘛	嘗	嗽	嘔	嘆	嘉	嘍	嘍	嘍	嘍	嘍	嘍	嘍	嘍	嘍	嘍
D	塵	塾	境	墓	塾	塾	墅	塽	壽	夥	夢	夤	奪	盜	嫡	嫡
E	嫩	嫗	嫗	嫗	嫗	嫗	寔	寧	寡	寥	實	寒	寢	寢	察	對
F	屢	屨	屨	屨	屨	屨	屨	屨	屨	屨	屨	屨	屨	屨	屨	屨

BC	0	1	2	3	4	5	6	7	8	9	A	B	C	D	E	F
4	劇	劈	劉	劍	創	颯	厲	嘖	嘻	嘖	嘖	嘖	嘖	嘖	嘖	嘖
5	嘖	嘖	嘖	嘖	嘖	嘖	嘖	嘖	嘖	嘖	嘖	嘖	嘖	嘖	嘖	嘖
6	嬋	嫵	嬌	嬌	寮	寬	審	寫	層	履	嶝	嶝	嶝	嶝	嶝	嶝
7	廚	廟	廟	廣	廠	彈	影	德	徵	慶	慧	慮	慮	慮	慮	慮
A	?	感	慰	愆	愆	愆	憐	憐	憐	憐	憐	憐	憐	憐	憐	憐
B	摯	摯	撞	撲	撈	撐	撰	撥	撓	撓	撓	撓	撓	撓	撓	撓
C	撬	擗	擗	擗	敵	敷	敷	暮	暫	暴	暍	樣	樟	榔	椿	樞
D	標	槽	模	樓	樊	樂	樂	樅	械	樑	歐	歎	湯	毅	毆	漿
E	潼	澄	潑	潑	潔	澆	潭	潛	潛	潮	澎	潺	潰	潤	潤	潘
F	滕	潑	潑	潑	熟	熬	熬	熬	熬	熬	熬	熬	熬	熬	熬	熬

BA	0	1	2	3	4	5	6	7	8	9	A	B	C	D	E	F
4	愿	態	慷	慢	慣	慟	慟	慟	截	撤	摘	摔	撒	摸	摸	摸
5	摺	摺	摧	摺	摺	摺	摺	摺	摺	摺	摺	摺	摺	摺	摺	摺
6	槁	榮	槓	構	榛	榷	榷	榷	榷	榷	榷	榷	榷	榷	榷	榷
7	歉	歌	氤	漳	演	滾	瀉	滴	游	漾	漠	瀆	漏	漂	漢	?
A	?	滿	滯	漆	漱	漸	漲	漣	漕	漫	濕	澈	漪	滬	漁	滲
B	滌	滌	熔	熙	煽	熊	熄	熒	爾	犒	犖	獄	犖	瑤	瑣	瑪
C	瑰	瑤	甄	疑	瘡	瘍	瘋	瘡	瘡	盡	監	睞	睞	睿	睡	磁
D	碟	碧	碳	碩	碣	禎	福	禍	種	稱	窪	窩	竭	端	管	箕
E	箋	筵	算	箝	箝	箝	箝	箝	箝	粹	粽	精	綻	縮	綜	綽
F	綾	綠	緊	綴	網	網	綺	綢	綵	綸	維	緒	緇	綬	?	?

BD	0	1	2	3	4	5	6	7	8	9	A	B	C	D	E	F
4	瑾	瑾	畿	瘡	瘡	瘡	瘡	瘡	瘡	瘡	瘡	瘡	瘡	瘡	瘡	瘡
5	瞋	瞋	瞋	瞋	瞋	瞋	瞋	瞋	瞋	瞋	瞋	瞋	瞋	瞋	瞋	瞋
6	窈	窮	箭	箱	範	箴	篆	篇	篁	篁	篁	篁	篁	篁	篁	篁
7	絨	緬	緝	編	緣	線	緞	綏	緹	緹	緹	緹	緹	緹	緹	緹
A	?	翩	耦	脰	膜	膝	膠	膚	腓	蔗	蔽	蔚	蓮	蔬	蔭	蔓
B	蔑	蔣	蔡	荀	蓬	蔥	菰	蔞	蚶	蝶	蝠	蝦	蝸	蝨	蝨	蝨
C	蝗	蚪	輸	衛	衝	褐	複	褒	褓	褓	褓	褓	褓	褓	褓	褓
D	請	諸	課	諉	詔	調	誰	論	諍	諍	諍	諍	諍	諍	諍	諍
E	賞	賦	賤	賤	賤	賤	賤	賤	賤	賤	賤	賤	賤	賤	賤	賤
F	踢	踏	踩	踩	踩	踩	踩	踩	踩	踩	踩	踩	踩	踩	踩	踩

BB	0	1	2	3	4	5	6	7	8	9	A	B	C	D	E	F
4	罰	翠	翡	翟	聞	聚	肇	腐	膀	膏	膈	膊	腿	胛	臧	臺
5	與	緜	舞	髡	蓉	蒿	蓆	蓄	蒙	茫	蒲	蒜	蓋	蒸	蓀	蓆
6	蒐	蒼	蓑	蓑	蜿	蜜	蜻	蝻	蜥	蚱	蚱	蝨	蝨	蝨	蝨	蝨
7	裘	裏	裸	製	裱	裱	誦	誌	語	誣	認	誠	誓	誤	?	?
A	?	說	誥	誨	誘	誣	誣	誣	豪	貍	貌	賓	賑	除	赫	趙
B	趕	踴	輔	輒	輕	輓	辣	遠	邁	遜	遣	遙	遞	遞	遞	遞
C	鄙	鄙	鄙	醉	酸	酷	餘	鉸	銀	銅	銘	銖	銖	銖	銖	銖
D	鉸	銖	閩	閩	閩	閩	閩	閩	隙	障	際	雌	雒	需	靶	鞅
E	韶	頗	領	颯	颯	餅	餅	餉	駁	駁	駁	駁	駁	駁	駁	駁
F	鳶	鳳	麼	鼻	齊	億	儀	僻	僵	價	儂	儂	儂	儂	儂	儂

BE	0	1	2	3	4	5	6	7	8	9	A	B	C	D	E	F
4	輓	適	遮	遨	遭	遷	鄰	鄭	鄧	鄧	醇	醉	醋	醃	銻	銻
5	銷	鋪	鏽	鋤	鋁	銳	銖	鋒	鉗	鉗	鉗	鉗	鉗	鉗	鉗	鉗
6	霉	靠	鞍	鞋	鞏	頤	頤	頤	鬚	鬚	鬚	鬚	鬚	鬚	鬚	鬚
7	駛	駑	駕	駒	駟	鬣	鬣	鬣	鬣	鬣	鬣	鬣	鬣	鬣	鬣	鬣
A	?	馱	馱	馱	馱	馱	馱	馱	馱	馱	馱	馱	馱	馱	馱	馱
B	劓	勳	噙	噙	噙	噙	噙	噙	噙	噙	噙	噙	噙	噙	噙	噙
C	壁	壘	壇	壘	奮	嫵	羸	學	寰	導	彊	憲	憑	憑	憑	憑
D	憶	憾	懊	懈	戰	擅	擁	擋	撻	撻	撻	撻	撻	撻	撻	撻
E	擒	擔	撈	整	曆	曉	暹	暹	暹	暹	暹	暹	暹	暹	暹	暹
F	樹	橄	橢	橡	橋	橋	橋	橋	橋	橋	橋	橋	橋	橋	橋	橋



晶發科技股份有限公司 GI FAR TECHNOLOGY CO., LTD.

No. 81, Dongfeng St, Shulin District, 238034, New Taipei City, Taiwan, R.O.C.



BF	0	1	2	3	4	5	6	7	8	9	A	B	C	D	E	F
4	濃	澤	濁	澧	澳	激	澹	澶	滙	滙	熾	熾	熾	熾	熾	燈
5	燕	烹	燎	燙	爛	燃	燄	獨	璜	璣	璘	璘	璘	璘	璘	璘
6	瘡	痼	痼	窟	窟	窟	窟	窟	窟	窟	窟	窟	窟	窟	窟	窟
7	穆	穌	穆	窺	窺	窺	窺	窺	窺	窺	窺	窺	窺	窺	窺	窺
A	?	縑	縑	縑	縑	縑	縑	縑	縑	縑	縑	縑	縑	縑	縑	縑
B	膩	膨	臻	興	艘	艘	艘	艘	艘	艘	艘	艘	艘	艘	艘	艘
C	螃	螟	媽	螢	融	衡	褪	褪	褪	褪	褪	褪	褪	褪	褪	褪
D	諱	謀	謀	諧	諮	諮	謂	謂	謂	謂	謂	謂	謂	謂	謂	謂
E	賴	蹄	蹄	蹄	蹄	蹄	蹄	蹄	蹄	蹄	蹄	蹄	蹄	蹄	蹄	蹄
F	遲	遼	遺	鄴	醒	錠	錠	錠	錠	錠	錠	錠	錠	錠	錠	錠

C2	0	1	2	3	4	5	6	7	8	9	A	B	C	D	E	F
4	駿	鮮	蛟	鮑	鮭	鴻	鵠	麩	黏	黏	黜	黜	黜	黜	黜	黜
5	嚕	嚕	嚕	嚕	嚕	嚕	嚕	嚕	嚕	嚕	嚕	嚕	嚕	嚕	嚕	嚕
6	曜	朦	檳	檳	檳	檳	檳	檳	檳	檳	檳	檳	檳	檳	檳	檳
7	瀆	濺	濺	濺	濺	濺	濺	濺	濺	濺	濺	濺	濺	濺	濺	濺
A	?	瘡	瞽	瞽	瞽	瞽	瞽	瞽	瞽	瞽	瞽	瞽	瞽	瞽	瞽	瞽
B	篔	篔	篔	篔	篔	篔	篔	篔	篔	篔	篔	篔	篔	篔	篔	篔
C	臍	臍	臍	臍	臍	臍	臍	臍	臍	臍	臍	臍	臍	臍	臍	臍
D	覆	觀	觴	謨	謹	謬	謬	謬	謬	謬	謬	謬	謬	謬	謬	謬
E	轉	輒	邇	邇	邇	醫	醫	醫	醫	醫	醫	醫	醫	醫	醫	醫
F	銅	鎚	鎚	鎚	鎚	鎚	鎚	鎚	鎚	鎚	鎚	鎚	鎚	鎚	鎚	鎚

C0	0	1	2	3	4	5	6	7	8	9	A	B	C	D	E	F
4	錐	錦	錡	錡	錡	錡	錡	錡	錡	錡	錡	錡	錡	錡	錡	錡
5	霏	靛	靛	靛	靛	靛	靛	靛	靛	靛	靛	靛	靛	靛	靛	靛
6	餡	餡	駭	駭	駭	駭	駭	駭	駭	駭	駭	駭	駭	駭	駭	駭
7	鴛	默	黔	龍	龜	優	償	償	償	償	償	償	償	償	償	償
A	?	噉	壕	壓	壑	壑	壑	壑	壑	壑	壑	壑	壑	壑	壑	壑
B	幫	彌	微	應	懂	懇	懦	懋	戲	戴	擊	擊	擊	擊	擊	擊
C	擬	擱	擱	擱	擱	擱	擱	擱	擱	擱	擱	擱	擱	擱	擱	擱
D	槩	檣	檣	歎	歎	歎	歎	歎	歎	歎	濠	濠	濠	濠	濠	濠
E	濬	濡	溲	濕	濮	滌	營	營	營	營	燥	燥	燥	燥	燥	燥
F	牆	羶	獲	瓌	環	瓊	瓊	瘡	瘡	瘡	瘡	瘡	瘡	瘡	瘡	瘡

C3	0	1	2	3	4	5	6	7	8	9	A	B	C	D	E	F
4	鞭	靛	靛	顏	題	顎	顛	颯	餉	餉	餉	餉	餉	餉	餉	餉
5	鬆	魏	魘	魘	鯉	鯉	鯉	鯉	鯉	鯉	鯉	鯉	鯉	鯉	鯉	鯉
6	嘸	壞	壘	壘	龍	龐	廬	懲	懷	懶	懶	懶	懶	懶	懶	懶
7	檳	檳	檳	檳	檳	檳	檳	檳	檳	檳	檳	檳	檳	檳	檳	檳
A	?	獼	璽	瓊	瓣	疇	疆	癩	癩	癩	癩	癩	癩	癩	癩	癩
B	籛	籛	籛	籛	籛	籛	籛	籛	籛	籛	籛	籛	籛	籛	籛	籛
C	藝	藪	藪	藪	藪	藪	藪	藪	藪	藪	藪	藪	藪	藪	藪	藪
D	譜	識	證	譚	譚	譚	譚	譚	譚	譚	譚	譚	譚	譚	譚	譚
E	蹴	麟	麟	辭	邊	邊	邊	邊	邊	邊	邊	邊	邊	邊	邊	邊
F	鏢	鏢	鏢	鏢	鏢	鏢	鏢	鏢	鏢	鏢	鏢	鏢	鏢	鏢	鏢	鏢

C1	0	1	2	3	4	5	6	7	8	9	A	B	C	D	E	F
4	瞧	瞭	矯	磷	礮	礮	礮	礮	礮	礮	礮	礮	礮	礮	礮	礮
5	簌	簌	糠	糜	糞	糞	糞	糞	糞	糞	糞	糞	糞	糞	糞	糞
6	總	縱	縲	繁	絳	縲	縲	縲	縲	縲	縲	縲	縲	縲	縲	縲
7	聯	竺	臆	臆	膺	膺	膺	膺	膺	膺	膺	膺	膺	膺	膺	膺
A	?	薄	菁	薛	薑	薯	薯	薯	薯	薯	薯	薯	薯	薯	薯	薯
B	蝮	螫	蝮	螺	蝮	蝮	蝮	蝮	蝮	蝮	蝮	蝮	蝮	蝮	蝮	蝮
C	謊	謠	謝	謔	謔	謔	謔	謔	謔	謔	謔	謔	謔	謔	謔	謔
D	蹈	蹊	轄	輓	輓	輓	輓	輓	輓	輓	輓	輓	輓	輓	輓	輓
E	醜	鍍	鍍	鍍	鍍	鍍	鍍	鍍	鍍	鍍	鍍	鍍	鍍	鍍	鍍	鍍
F	闕	闕	闕	闕	闕	闕	闕	闕	闕	闕	闕	闕	闕	闕	闕	闕

C4	0	1	2	3	4	5	6	7	8	9	A	B	C	D	E	F
4	願	顛	颯	颯	鯨	鯨	鯨	鯨	鯨	鯨	鯨	鯨	鯨	鯨	鯨	鯨
5	鵬	麒	麗	麗	麗	麗	麗	麗	麗	麗	麗	麗	麗	麗	麗	麗
6	嶼	懸	巖	攘	攔	攔	攔	攔	攔	攔	攔	攔	攔	攔	攔	攔
7	癢	礦	礪	礪	礪	礪	礪	礪	礪	礪	礪	礪	礪	礪	礪	礪
A	?	纂	畧	耀	臚	臚	臚	臚	臚	臚	臚	臚	臚	臚	臚	臚
B	檻	覺	觸	議	警	警	譯	譯	譯	譯	譯	譯	譯	譯	譯	譯
C	釋	鐘	鏡	鋪	聞	霰	飄	饒	饒	饒	饒	饒	饒	饒	饒	饒
D	鹹	麵	黨	颯	齟	齟	齟	齟	齟	齟	齟	齟	齟	齟	齟	齟
E	孺	攝	攜	攜	攜	攜	攜	攜	攜	攜	攜	攜	攜	攜	攜	攜
F	籐	纏	纏	纏	籐	籐	籐	籐	籐	籐	籐	籐	籐	籐	籐	籐



C5	0	1	2	3	4	5	6	7	8	9	A	B	C	D	E	F
4	護	譽	賦	躊	躍	躋	轟	辯	醜	鏃	鋪	鐵	錯	鐸	鐳	鑄
5	關	霸	譯	露	響	顧	顯	饗	驅	騾	騾	體	魔	魘	鱒	
6	鰈	鶯	鶴	鷓	鷓	鸞	鸞	齋	齋	齋	齋	齋	齋	齋	齋	齋
7	學	巔	巔	巔	巔	巔	巔	巔	巔	巔	巔	巔	巔	巔	巔	巔
A		讓	籠	籟	聽	臧	襲	親	艘	讀	贖	質	躑	躑	躑	躑
B	麗	鑄	鑑	鑿	齊	靈	韃	韃	顛	鸞	驕	驕	驕	驕	驕	驕
C	鏢	鰓	鷓	鷓	鷓	鷓	鷓	鷓	鷓	鷓	鷓	鷓	鷓	鷓	鷓	鷓
D	瓊	竊	籤	簡	箭	纓	織	纒	贖	蕪	蘿	蠱	變	運	運	運
E	鑲	鏗	鑿	顯	駭	駭	駭	駭	駭	駭	駭	駭	駭	駭	駭	駭
F	徹	囑	塌	攪	瀟	瀟	瀟	瀟	瀟	瀟	瀟	瀟	瀟	瀟	瀟	瀟

C8	0	1	2	3	4	5	6	7	8	9	A	B	C	D	E	F
4																
5																
6																
7																
A																
B																
C																
D																
E																
F																

C6	0	1	2	3	4	5	6	7	8	9	A	B	C	D	E	F
4	識	艷	韻	釀	鑑	靈	靈	靈	靈	靈	靈	靈	靈	靈	靈	靈
5	嶮	鹽	釐	蠟	蝸	聽	攪	灣	籬	籬	蠟	蠟	蠟	蠟	蠟	蠟
6	顛	饒	饒	饒	饒	饒	饒	饒	饒	饒	饒	饒	饒	饒	饒	饒
7	鑽	鑿	鑿	鑿	鑿	鑿	鑿	鑿	鑿	鑿	鑿	鑿	鑿	鑿	鑿	鑿
A																
B																
C																
D																
E	□	□	□	一				あ	い	い	う	う	え	え	お	
F	お	か	が	き	ぎ	く	ぐ	け	げ	こ	ご	さ	ざ	し	じ	

C7	0	1	2	3	4	5	6	7	8	9	A	B	C	D	E	F
4	す	ず	せ	ぜ	そ	ぞ	た	だ	ち	ち	つ	つ	づ	て	と	
5	ど	な	に	ぬ	ね	の	は	ば	び	び	び	ふ	ぶ	へ		
6	べ	へ	ほ	ぼ	ま	み	む	め	も	や	や	ゆ	ゆ	よ		
7	ら	り	る	れ	ろ	わ	わ	ゑ	を	ん	ア	ア	イ	イ		
A		ウ	ウ	エ	エ	オ	オ	カ	カ	キ	キ	ク	ク	ケ	ケ	コ
B		ゴ	サ	ザ	シ	ジ	ス	セ	ゼ	ソ	ゾ	タ	ダ	チ	チ	ツ
C		ツ	ツ	テ	デ	ト	ド	ナ	ニ	ヌ	ネ	ノ	ハ	バ	バ	ヒ
D		ピ	フ	フ	フ	ヘ	ベ	ベ	ホ	ボ	ボ	マ	ミ	ム	メ	モ
E		ヤ	ユ	ユ	ヨ	ヨ	ラ	リ	ル	レ	ロ	ワ	ワ	キ	エ	フ
F		ヴ	カ	ケ												

0	1	2	3	4	5	6	7	8	9	A	B	C	D	E	F
0	☺	☻	♠	♣	♦	♥	♠	♣	♦	♥	♠	♣	♦	♥	♠
1	▶	◀	♠	♣	♠	♣	♠	♣	♠	♣	♠	♣	♠	♣	♠
2	!	"	#	\$	%	&	'	()	*	+	,	-	.	/
3	0	1	2	3	4	5	6	7	8	9	:	;	<	=	>
4	@	A	B	C	D	E	F	G	H	I	J	K	L	M	N
5	P	Q	R	S	T	U	V	W	X	Y	Z	[\	^	_
6	'	a	b	c	d	e	f	g	h	i	j	k	l	m	n
7	p	q	r	s	t	u	v	w	x	y	z	{		}	~
8	¥	.	!	!	!	!	!	!	!	!	!	!	!	!	!
9	É	æ	œ	ô	ö	û	ü	ÿ	ŷ	Ź	ƒ	£	¥	¢	ƒ
A	á	í	ó	ú	ñ	Ñ	º	º	º	º	º	º	º	º	º
B															
C	¡	¡	¡	¡	¡	¡	¡	¡	¡	¡	¡	¡	¡	¡	¡
D	¡	¡	¡	¡	¡	¡	¡	¡	¡	¡	¡	¡	¡	¡	¡
E	α	β	γ	π	σ	μ	τ	θ	ω	δ	∞	∞	∞	∞	∞
F	≡	±	≥	≤	∫	∫	∫	∫	∫	∫	∫	∫	∫	∫	∫

0	1	2	3	4	5	6	7	8	9	A	B	C	D	E	F
0	Á	á	Ä	ä	À	à	Ç	ç	Ĉ	ĉ	Ĉ	ĉ	Ĉ	ĉ	Ĉ
1	Đ	đ	Ě	ě	Ě	ě	Ě	ě	Ě	ě	Ě	ě	Ě	ě	Ě
2	Ĝ	ĝ	Ĝ	ĝ	Ĝ	ĝ	Ĝ	ĝ	Ĝ	ĝ	Ĝ	ĝ	Ĝ	ĝ	Ĝ
3	Ī	ī	Ī	ī	Ī	ī	Ī	ī	Ī	ī	Ī	ī	Ī	ī	Ī
4	Ĳ	ĳ	Ń	ń	Ń	ń	Ń	ń	Ń	ń	Ń	ń	Ń	ń	Ń
5	Œ	œ	Œ	œ	Œ	œ	Œ	œ	Œ	œ	Œ	œ	Œ	œ	Œ
6	Š	š	Š	š	Š	š	Š	š	Š	š	Š	š	Š	š	Š
7	Ů	ů	Ů	ů	Ů	ů	Ů	ů	Ů	ů	Ů	ů	Ů	ů	Ů
8	ǃ	ǂ	ǃ	ǂ	ǃ	ǂ	ǃ	ǂ	ǃ	ǂ	ǃ	ǂ	ǃ	ǂ	ǃ
9	Ɛ	ƒ	ƒ	ƒ	ƒ	ƒ	ƒ	ƒ	ƒ	ƒ	ƒ	ƒ	ƒ	ƒ	ƒ
A	Œ	Œ	Œ	Œ	Œ	Œ	Œ	Œ	Œ	Œ	Œ	Œ	Œ	Œ	Œ
B	ǃ	ǃ	ǃ	ǃ	ǃ	ǃ	ǃ	ǃ	ǃ	ǃ	ǃ	ǃ	ǃ	ǃ	ǃ
C	ǃ	ǃ	ǃ	ǃ	ǃ	ǃ	ǃ	ǃ	ǃ	ǃ	ǃ	ǃ	ǃ	ǃ	ǃ
D	ǃ	ǃ	ǃ	ǃ	ǃ	ǃ	ǃ	ǃ	ǃ	ǃ	ǃ	ǃ	ǃ	ǃ	ǃ
E	ǃ	ǃ	ǃ	ǃ	ǃ	ǃ	ǃ	ǃ	ǃ	ǃ	ǃ	ǃ	ǃ	ǃ	ǃ
F	ǃ	ǃ	ǃ	ǃ	ǃ	ǃ	ǃ	ǃ	ǃ	ǃ	ǃ	ǃ	ǃ	ǃ	ǃ

0	1	2	3	4	5	6	7	8	9	A	B	C	D	E	F
0	Á	á	Ä	ä	À	à	Ç	ç	Ĉ	ĉ	Ĉ	ĉ	Ĉ	ĉ	Ĉ
1	Đ	đ	Ě	ě	Ě	ě	Ě	ě	Ě	ě	Ě	ě	Ě	ě	Ě
2	Ĝ	ĝ	Ĝ	ĝ	Ĝ	ĝ	Ĝ	ĝ	Ĝ	ĝ	Ĝ	ĝ	Ĝ	ĝ	Ĝ
3	Ī	ī	Ī	ī	Ī	ī	Ī	ī	Ī	ī	Ī	ī	Ī	ī	Ī
4	Ĳ	ĳ	Ń	ń	Ń	ń	Ń	ń	Ń	ń	Ń	ń	Ń	ń	Ń
5	Œ	œ	Œ	œ	Œ	œ	Œ	œ	Œ	œ	Œ	œ	Œ	œ	Œ
6	Š	š	Š	š	Š	š	Š	š	Š	š	Š	š	Š	š	Š
7	Ů	ů	Ů	ů	Ů	ů	Ů	ů	Ů	ů	Ů	ů	Ů	ů	Ů
8	ǃ	ǂ	ǃ	ǂ	ǃ	ǂ	ǃ	ǂ	ǃ	ǂ	ǃ	ǂ	ǃ	ǂ	ǃ
9	Ɛ	ƒ	ƒ	ƒ	ƒ	ƒ	ƒ	ƒ	ƒ	ƒ	ƒ	ƒ	ƒ	ƒ	ƒ
A	Œ	Œ	Œ	Œ	Œ	Œ	Œ	Œ	Œ	Œ	Œ	Œ	Œ	Œ	Œ
B	ǃ	ǃ	ǃ	ǃ	ǃ	ǃ	ǃ	ǃ	ǃ	ǃ	ǃ	ǃ	ǃ	ǃ	ǃ
C	ǃ	ǃ	ǃ	ǃ	ǃ	ǃ	ǃ	ǃ	ǃ	ǃ	ǃ	ǃ	ǃ	ǃ	ǃ
D	ǃ	ǃ	ǃ	ǃ	ǃ	ǃ	ǃ	ǃ	ǃ	ǃ	ǃ	ǃ	ǃ	ǃ	ǃ
E	ǃ	ǃ	ǃ	ǃ	ǃ	ǃ	ǃ	ǃ	ǃ	ǃ	ǃ	ǃ	ǃ	ǃ	ǃ
F	ǃ	ǃ	ǃ	ǃ	ǃ	ǃ	ǃ	ǃ	ǃ	ǃ	ǃ	ǃ	ǃ	ǃ	ǃ

Table E-1: 小 ASCII 表

Table E-2: 大 ASCII 表

Table E-3: 大 ASCII 表



5. NOTES

Safety

- If the LCD panel breaks, be careful not to get the liquid crystal in your mouth. If the liquid crystal touches your skin or clothes, wash it off immediately using soap and plenty of water.

Handling

- Avoid static electricity as this can damage the CMOS LSI.
- The LCD panel is plate glass; do not hit or crush it.
- Do not remove the panel or frame from the module.
- The polarizing plate of the display is very fragile; handle it very carefully

Mounting and Design

- Mount the module by using the specified mounting part and holes.
- To protect the module from external pressure, leave a small gap by placing transparent plates (e.g. acrylic or glass) on the display surface, frame, and polarizing plate
- Design the system so that no input signal is given unless the power-supply voltage is applied.
- Keep the module dry. Avoid condensation, otherwise the transparent electrodes may break.

Storage

- Store the module in a dark place where the temperature is $25\text{ }^{\circ}\text{C}\pm 10\text{ }^{\circ}\text{C}$ and the humidity below 65% RH.
- Do not store the module near organic solvents or corrosive gases.
- Do not crush, shake, or jolt the module (including accessories).

Cleaning

- Do not wipe the polarizing plate with a dry cloth, as it may scratch the surface.
- Wipe the module gently with soft cloth soaked with a petroleum benzine.
- Do not use ketonic solvents (ketone and acetone) or aromatic solvents (toluene and xylene), as they may damage the polarizing plate.

6. OPERATION PRECAUTIONS

Any changes that need to be made in this specification or any problems arising from it will be dealt with quickly by discussion between both companies.

Quality warranty period: Within one year after shipment date (excluding abnormal usage way and abnormal environments.)



7. LCM Dimension

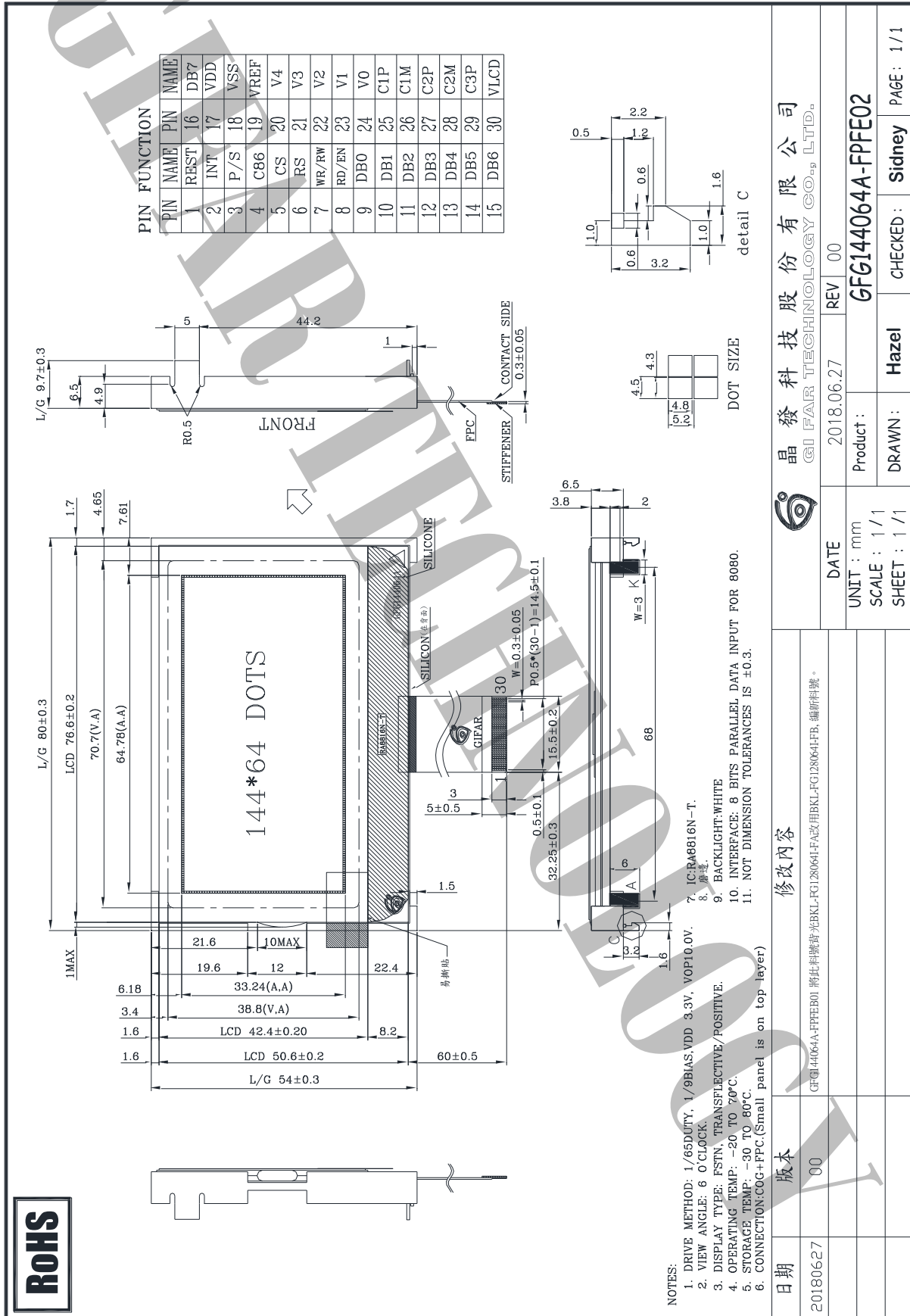

晶發科技股份有限公司
GI FAR TECHNOLOGY CO., LTD.



修改內容

版本

日期

20180627	00	GF0144064A-PPFE01 將此料號更改為BKL-FG1280641-FA改用BKL-FG1280644-FFB, 備新料號。
2018.06.27	REV 00	
UNIT : mm	Product :	GF0144064A-PPFE02
SCALE : 1/1	DRAWN :	Hazel
SHEET : 1/1	CHECKED :	Sidney
	PAGE :	1/1



8. PACKAGE INFORMATION

1	1 Tray	:	12 pcs (modules)
2	1 stack	:	12 tray +1 Cover tray
3	1 Carton	:	(1 Cover tray + 12 tray)x 2 stack
4	Total pcs	:	1 Carton (12pcs*12tray * 2 stack) = 192 pcs
5	Carton size = NO. 17	:	495*315*435mm
7	Net weight	:	6.1 KG
8	Gross weight	:	10.7 KG

** 包裝示意圖片

- 一個 tray 盤 可放 12PCS 模組



- 12 盤+1 空盤=1 疊，一箱可放入 2 疊，TRAY 盤需交叉堆疊放置。



- 使用 17 號箱，可放入 2 疊，並使用防震材將旁邊空隙填滿



出貨檢驗標準書
Shipping inspection standard

核准 Approved by	審核 Checked by	作成 Made by
ANDY	JACKY	RUBY

1.目的 Purpose :

規範出貨產品之檢驗項目及判斷標準，確保產品出貨能滿足客戶要求。

Standardize the inspection items and judgment standards to ensure the products that shipped out can meet customer's requirements.

2.範圍 Area :

適用於出廠之所有產品。

Applicable to all products shipped from the factory.

3.名詞解釋 Explanation of terms :

3-1 主要缺陷：亦會造成功能缺失或嚴重外觀缺陷。

Major Defects: It also causes loss of function or serious appearance defects.

3-2 次要缺陷：稍有缺陷但不影響客戶使用。

Minor defect: Slightly defective but does not affect customer use.

4.檢驗體制 Inspection system :

4-1 抽樣計劃：依 ANSI/ASQ Z1.4 一般檢驗水準 II 之 正常檢驗一次抽驗方案。

Sampling plan: According to ANSI/ASQ Z1.4 general inspection level II the normal inspection one-time sampling plan.

4-2 允收水準 Acceptable Level : (AQL)

主要缺陷 Major defect : 0.4 %

次要缺陷 Minor defect : 0.65 %

5.檢驗條件 Inspection conditions :

5-1 使用相關之檢測儀器及測試、量測工具。

Use relevant testing instrument, testing and measuring tools .

5-2 環境要求：其條件需控制在常溫下 $23^{\circ}\text{C}\pm 3^{\circ}\text{C}$ 及溼度 70%RH 以下。

Environmental requirements: The conditions should be controlled at room temperature $23^{\circ}\text{C}\pm 3^{\circ}\text{C}$ and humidity below 70%RH.

5-3 外觀檢驗：須在 $380\pm 20\%$ LUX 的白色日光燈下，其目視距離需於產品離 30 ± 5 cm 檢驗。

Appearance inspection: Under the white fluorescent lamp of $380\pm 20\%$ LUX , the visual distance shall be checked above the product 30 ± 5 cm.

5-4 電性測試 Electrical Testing :

5-4-1 有背光之產品需關燈並在 $5\sim 300\text{Lux}\pm 3\%$ 下檢驗。

The products with backlight should be tested at $5\sim 300\pm 3\%$ Lux.

5-4-2 無背光之產品需開燈並在 $60\sim 300\text{Lux}\pm 3\%$ 白色日光燈下檢驗。

Products without backlight need to be turned on and tested under $60\sim 300 \pm 3\%$ LUX white fluorescent lamps .

5-5 檢查視角依產品視角方向。

Check the viewing angle according to the product viewing angle.

5-6 其不良現象檢視區域 Bad phenomenon View area

5-6-1 適用種類 Applicable category : COB、TFT

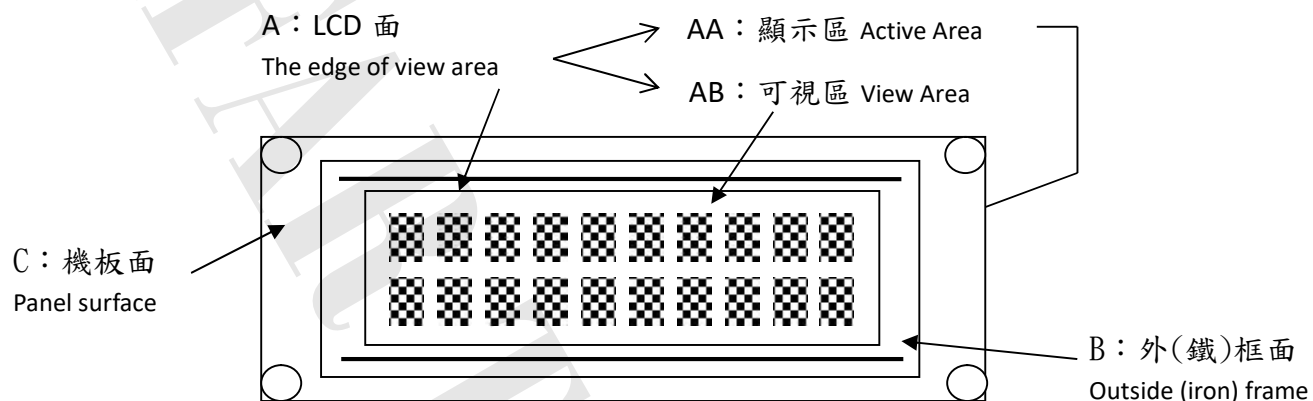

5-6-2 適用種類 Applicable category : COG、TAB、TN

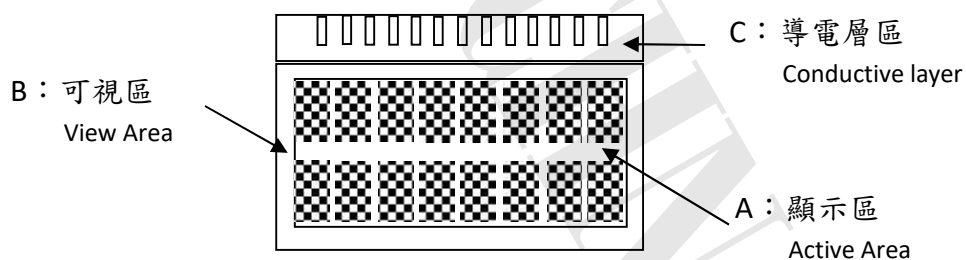

種類 Category		COG																			
編號 No.	檢驗項目 Item	檢驗內容及判定標準 Inspection Content & Standard			區域 Zone	類別 Category	缺陷等級 Level														
1	點類(一) Dot(1)	黑點、刺傷...等圓狀 Black dot、Stab...and other round shape $\phi = \frac{(X + Y)}{2}$ 	兩點距離須超過 5 mm Two points have to be ≥ 5 mm		A B	外觀 Appearance	次要 Minor AQL0.65%														
		ϕ (mm)	允收數 Acceptance Qty																		
		$\phi \leq 0.1$	無視 Ignore																		
		$0.1 < \phi \leq 0.25$	3																		
		$0.25 < \phi \leq 0.3$	1																		
		$\phi > 0.3$	0																		
2	點類(二) Dot(2)	氣泡、凹凸點 Bubble、Uneven dots $\phi = \frac{(X + Y)}{2}$ 	兩點距離須超過 5 mm Two points have to be ≥ 5 mm		A B	外觀 Appearance	次要 Minor AQL0.65%														
		ϕ (mm)	允收數 Acceptance Qty																		
		$\phi \leq 0.2$	無視 Ignore																		
		$0.2 < \phi \leq 0.5$	2																		
		$\phi > 0.5$	0																		
3	線類 Line	刮傷、毛屑...等線狀 Scratch、Fiber.. and other linear shape. 	<table border="1"> <thead> <tr> <th>L (mm)</th> <th>W (mm)</th> <th>允收數 Acceptance Qty</th> </tr> </thead> <tbody> <tr> <td>--</td> <td>$W \leq 0.02$</td> <td>無視 Ignore</td> </tr> <tr> <td>$L \leq 5$</td> <td>$W \leq 0.03$</td> <td>3</td> </tr> <tr> <td>$L \leq 3$</td> <td>$W \leq 0.05$</td> <td>2</td> </tr> <tr> <td>$L > 5$</td> <td>$W > 0.05$</td> <td>0</td> </tr> </tbody> </table>	L (mm)	W (mm)	允收數 Acceptance Qty	--	$W \leq 0.02$	無視 Ignore	$L \leq 5$	$W \leq 0.03$	3	$L \leq 3$	$W \leq 0.05$	2	$L > 5$	$W > 0.05$	0	A B	外觀 Appearance	次要 Minor AQL0.65%
L (mm)	W (mm)	允收數 Acceptance Qty																			
--	$W \leq 0.02$	無視 Ignore																			
$L \leq 5$	$W \leq 0.03$	3																			
$L \leq 3$	$W \leq 0.05$	2																			
$L > 5$	$W > 0.05$	0																			
4	底色 Background color	同批供貨不能有明顯色差 No obvious color difference allowed in same shipment. (必要時與客端制定限度樣) (According to the gold samples if necessary)			B	外觀 Appearance	次要 Minor AQL0.65%														
5	FPC 外觀 FPC Appearance	※ FPC 上刺傷導致線路無法導通 拒收 Stabbing on the FPC causes the line to fail to conduct Reject ※ FPC 上髒污或是殘留異物以致線路無法導通 拒收 Dirty or residual foreign matter on the FPC makes the circuit unable to conduct Reject ※ FPC 直角折痕、斷裂 拒收 FPC right-angle crease and fracture Reject			C	外觀 Appearance	主要 Major AQL 0.4%														

6	點、線類 (三) Dot、Line (3)	※ 於全黑、白畫面下看見之區塊狀或線狀不良 拒收 There is a block or linear in the view area under the screen is whole black or white. Reject ※ 但依 2% ND Filter 遮蓋無視 允收 But after inspecting by 2% ND Filter without seeing block or linear, it is confirmed Acceptance	A	電訊 Electronics	次要 Minor AQL0.65%
7	點、線類 (四) Dot、Line (4)	畫面中顯示出現黑、白、亮、異色點或線狀 There is a black, white, bright or other dot or lines showing in the view area. ※ 依編號 1、3 之判定標準 According to the inspection standard: No. 1 and 3.	A	電訊 Electronics	次要 Minor AQL0.65%
8	缺字 Lack of characters	顯示時畫面缺少部份字元 拒收 Lacking part of characters in the view area. Reject	A	電訊 Electronics	主要 Major AQL 0.4%
9	無動作 No reaction	顯示畫面一直處於起始畫面而無法進行切換 拒收 The display (view area) always show in the initial screen and can't be switched to others. Reject	A	電訊 Electronics	主要 Major AQL 0.4%
10	無畫面 No display	通電後，完全無任何畫面顯示 拒收 After connecting to the power, there is no image. Reject	A	電訊 Electronics	主要 Major AQL 0.4%
11	斷線 Broken line	顯示畫面中少直、橫線 拒收 There is a lack of vertical or horizontal lines in the view area. Reject	A	電訊 Electronics	主要 Major AQL 0.4%
12	CROSS TALK	顯示畫面時有局部之條紋或拖影 There are some stripes or shadow/smear showing in the view area. 拒收或與客端簽訂限度樣 Reject or inspect according to the golden sample	A	電訊 Electronics	次要 Minor AQL0.65%
13	I CON	顯示畫面缺少部份顯示圖案 拒收 Lack of partial ICON in the view area. Reject	A	電訊 Electronics	主要 Major AQL 0.4%

14	深淺不一 Color difference	顯示畫面的對比，比其他顯示深或淺並依電氣規格(VOP)值判定 The color contrast of display is obviously lighter or darker than others and according to the VOP value in the electronics specification. 拒收或與客端簽訂限度樣 Reject or inspect according to the golden sample	A	電訊 Electronics	次要 Minor AQL0.65%												
15	畫面異常 Abnormal screen	通電後畫面出現未定義之電訊不良現象 拒收 After connecting to the power, there is an undefined electronics appearance showing in the view area. Reject	A	電訊 Electronics	主要 Major AQL 0.4%												
16	背光色不均 Uneven color of backlight	※ 點亮後 LED 有明暗不均現象依其均勻度判定 拒收 After lighting LEDs have brightness and darkness uneven the determined according to its uniformity. Reject ※ 點亮後 LED 色澤不一致 拒收 LED color is inconsistent after lighting. Reject	A	電訊 Electronics	次要 Minor AQL0.65%												
17	亮度不足 Lack of brightness	波長、色座標、輝度與圖面標示定義不符 拒收 Wave length, chromatic coordinates, brightness don't correspond to the definition of the drawing. Reject	A	電訊 Electronics	主要 Major AQL 0.4%												
18	背光腳柱 Backlit foot post	斷裂、長度不一 拒收 Fracture, different length Reject	--	外觀 Appearance	次要 Minor AQL0.65%												
19	破損 Damaged	<p>Y：破損寬 X：破損長 Y: Damaged width X: Damaged length</p>  <table border="1"> <thead> <tr> <th>Y</th> <th>X</th> <th>判定 Determination</th> </tr> </thead> <tbody> <tr> <td>Y ≤ 1.0</td> <td>-- --</td> <td>允收 Acceptance</td> </tr> <tr> <td>未進入可視區 Did not enter the viewing area</td> <td>≤ 1/8 玻璃該邊長 ≤ 1/8 The side length of the glass</td> <td>允收 Acceptance</td> </tr> <tr> <td>進入可視區 Enter the viewing area</td> <td>-- --</td> <td>拒收 Reject</td> </tr> </tbody> </table>	Y	X	判定 Determination	Y ≤ 1.0	-- --	允收 Acceptance	未進入可視區 Did not enter the viewing area	≤ 1/8 玻璃該邊長 ≤ 1/8 The side length of the glass	允收 Acceptance	進入可視區 Enter the viewing area	-- --	拒收 Reject	B	外觀 Appearance	次要 Minor AQL0.65%
Y	X	判定 Determination															
Y ≤ 1.0	-- --	允收 Acceptance															
未進入可視區 Did not enter the viewing area	≤ 1/8 玻璃該邊長 ≤ 1/8 The side length of the glass	允收 Acceptance															
進入可視區 Enter the viewing area	-- --	拒收 Reject															

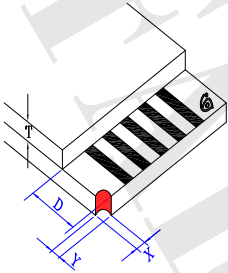
20	角崩 Corner collapse		Y：破損寬 X：破損長 Y: Damaged width X: Damaged length <table border="1" data-bbox="568 535 1102 846"> <thead> <tr> <th>Y</th> <th>X</th> <th>判定 Determination</th> </tr> </thead> <tbody> <tr> <td>$\leq 1/3D$</td> <td>-- --</td> <td>允收 Acceptance</td> </tr> <tr> <td>$1/3D < Y \leq D$</td> <td>$\leq 1/8$ 玻璃邊長 $\leq 1/8$ The side length of the glass</td> <td>允收 Acceptance</td> </tr> <tr> <td>$> D$</td> <td>-- --</td> <td>拒收 Reject</td> </tr> </tbody> </table>	Y	X	判定 Determination	$\leq 1/3D$	-- --	允收 Acceptance	$1/3D < Y \leq D$	$\leq 1/8$ 玻璃邊長 $\leq 1/8$ The side length of the glass	允收 Acceptance	$> D$	-- --	拒收 Reject	C	外觀 Appearance	次要 Minor AQL0.65%
Y	X	判定 Determination																
$\leq 1/3D$	-- --	允收 Acceptance																
$1/3D < Y \leq D$	$\leq 1/8$ 玻璃邊長 $\leq 1/8$ The side length of the glass	允收 Acceptance																
$> D$	-- --	拒收 Reject																
21	尺寸量測 Size Measurement	未依圖面上標示 拒收 No correspond to the indication on the drawing. Reject	ALL	外觀 Appearance	主要 Major AQL 0.4%													
22	其他 Other	如發現有上述未定義之不良則與客端簽訂限度樣 If there is another undefined defective situation. It will be listed as others. The inspection standard is according to the golden sample.	ALL	電訊 Electronics 外觀 Appearance	次要 Minor AQL0.65%													