

REVISIONS				
P	LTR	DESCRIPTION	DATE	APVD
B		REVISED PER ECR-19-009721	01JUL2019	M.G D.Z

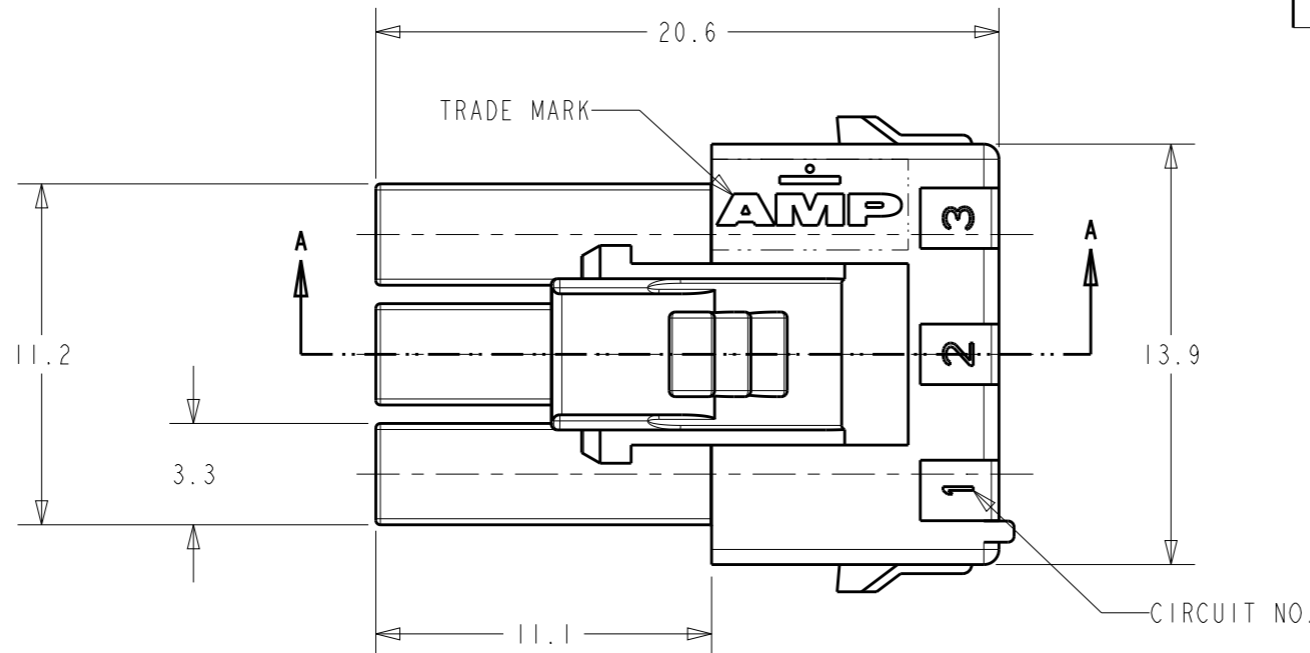

- 1 THIS HOUSING ACCEPTS RECEPTACLE TERMINAL:
 - REC CONTACT: 177915-□ (AWG #16-#20)
 : 177914-□ (AWG #22-#26)
- 2 MATING CONN. P/N
 - TAB CONTACT: 177917-□ (AWG #16-#20)
 : 177916-□ (AWG #22-#26)
- 3 APPLICABLE DOUBLE LOCK PLATE: 177919-□
 * IT SHOULD BE USED CERTAINLY WHEN CABLE ASS'Y
- 4 GENERAL TOLERANCES: ±0.3
- 5 MATERIAL: PA66,UL94V-0,
 COMPLY WITH GLOW WIRE REQUIREMENT FOR PARTS OF
 NON-METALLIC MATERIAL SUPPORTING A CURRENT-CARRYING
 CONNECTION DETAILED IN IEC 60335-1, SECTION 30(GWT)

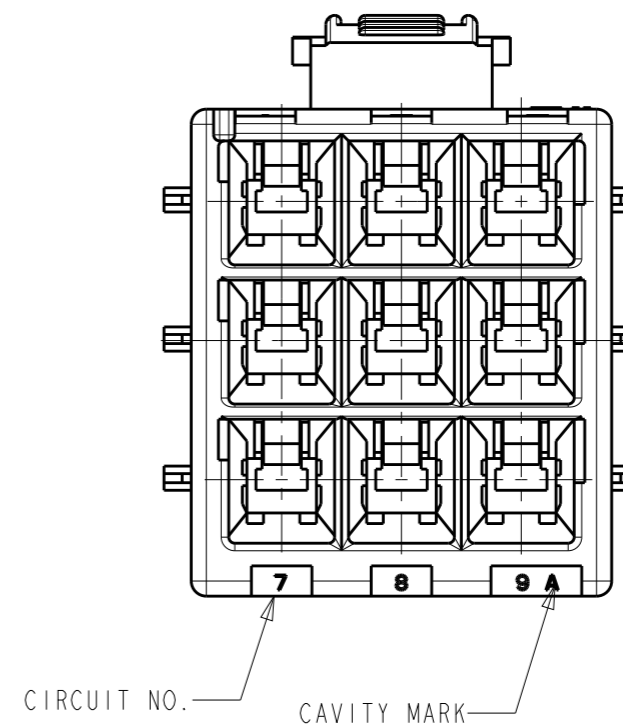
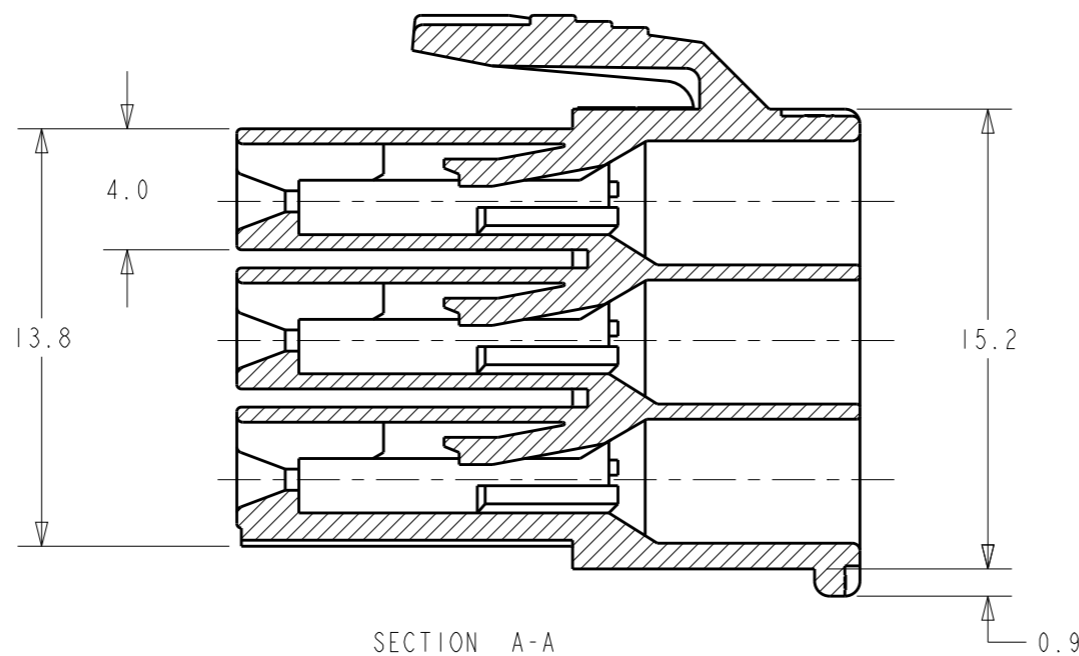
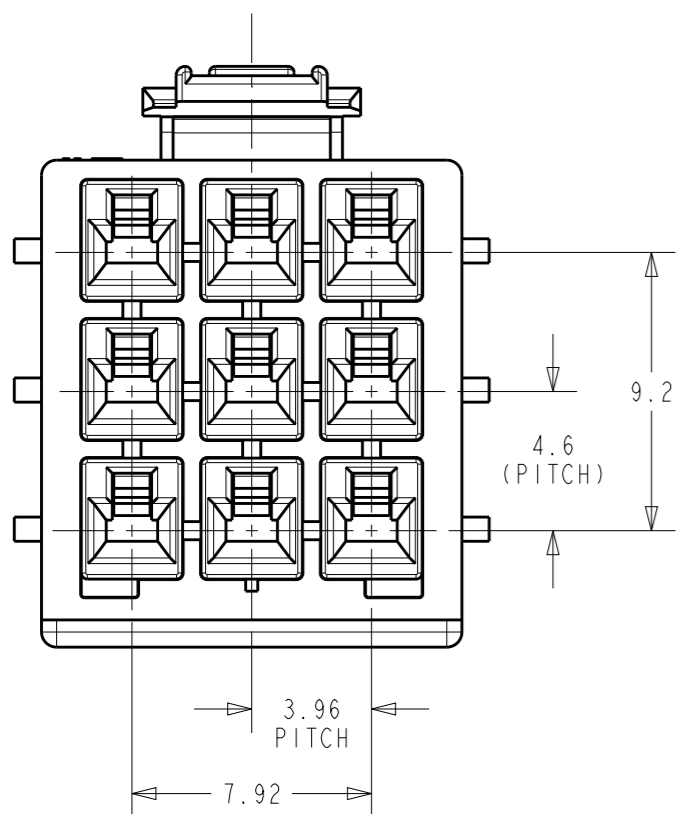

BLUE	2005254-6
YELLOW	2005254-4
NATURAL	2005254-1
COLOR	PART NUMBER

THIS DRAWING IS A CONTROLLED DOCUMENT.		DWN SC KIM		TE Connectivity	
DIMENSIONS: mm		CHK BW KANG			
		APVD JK SONG		NAME PDL 9P PLUG HSG 3.96MM T/R (GWT)	
		TOLERANCES UNLESS OTHERWISE SPECIFIED:		PRODUCT SPEC 108-5410	
MATERIAL 5		FINISH -		APPLICATION SPEC 114-5175	
		WEIGHT -		SIZE A3	
		CUSTOMER DRAWING		CAGE CODE 00779	
				DRAWING NO. C-2005254	
				RESTRICTED TO -	
				SCALE 4:1	
				SHEET 1 OF 1	
				REV B	