

REVISIONS					
P	LTR	DESCRIPTION	DATE	OWN	APVD
G		REVISED PER ECO-20-002047	20FEB2020	RK	MZ

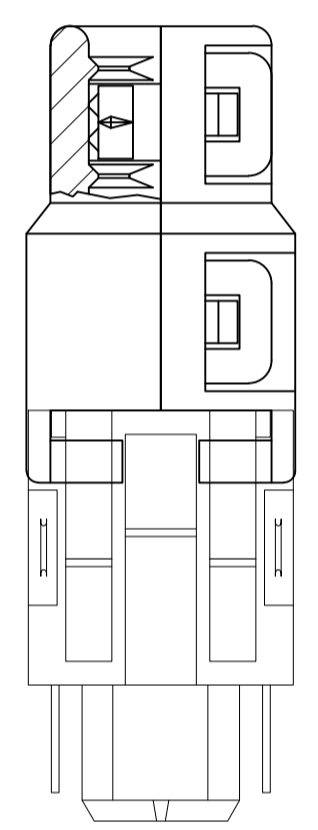

ASSEMBLED VIEW

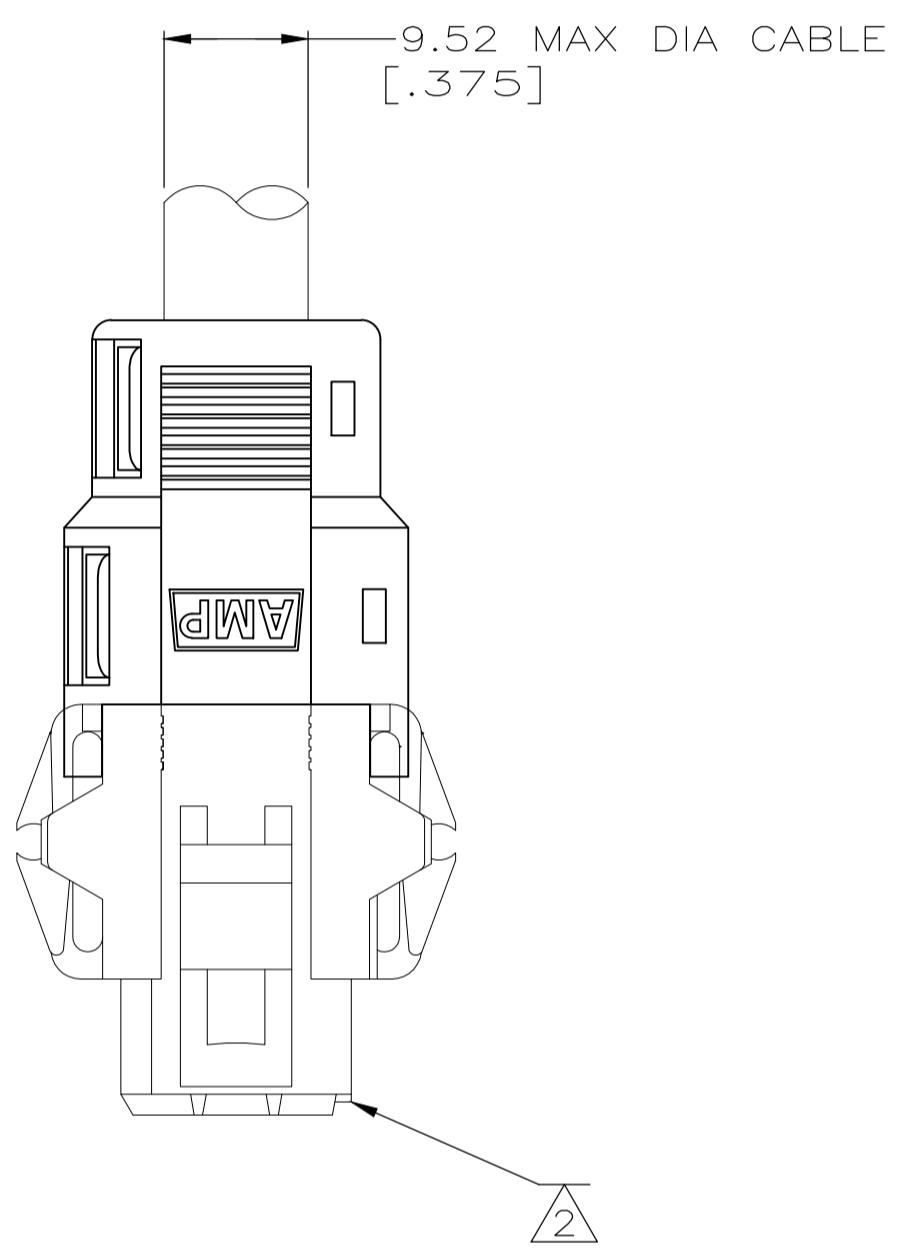
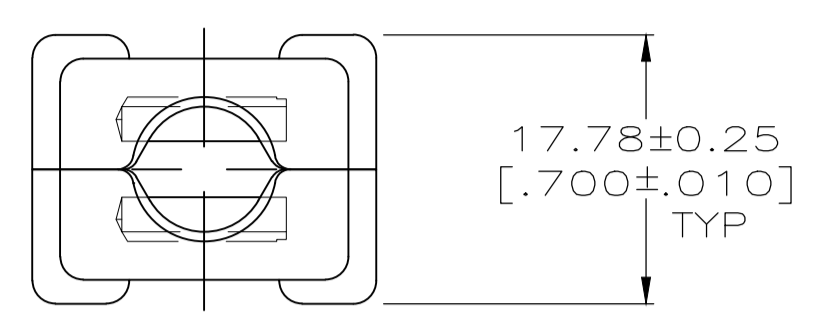
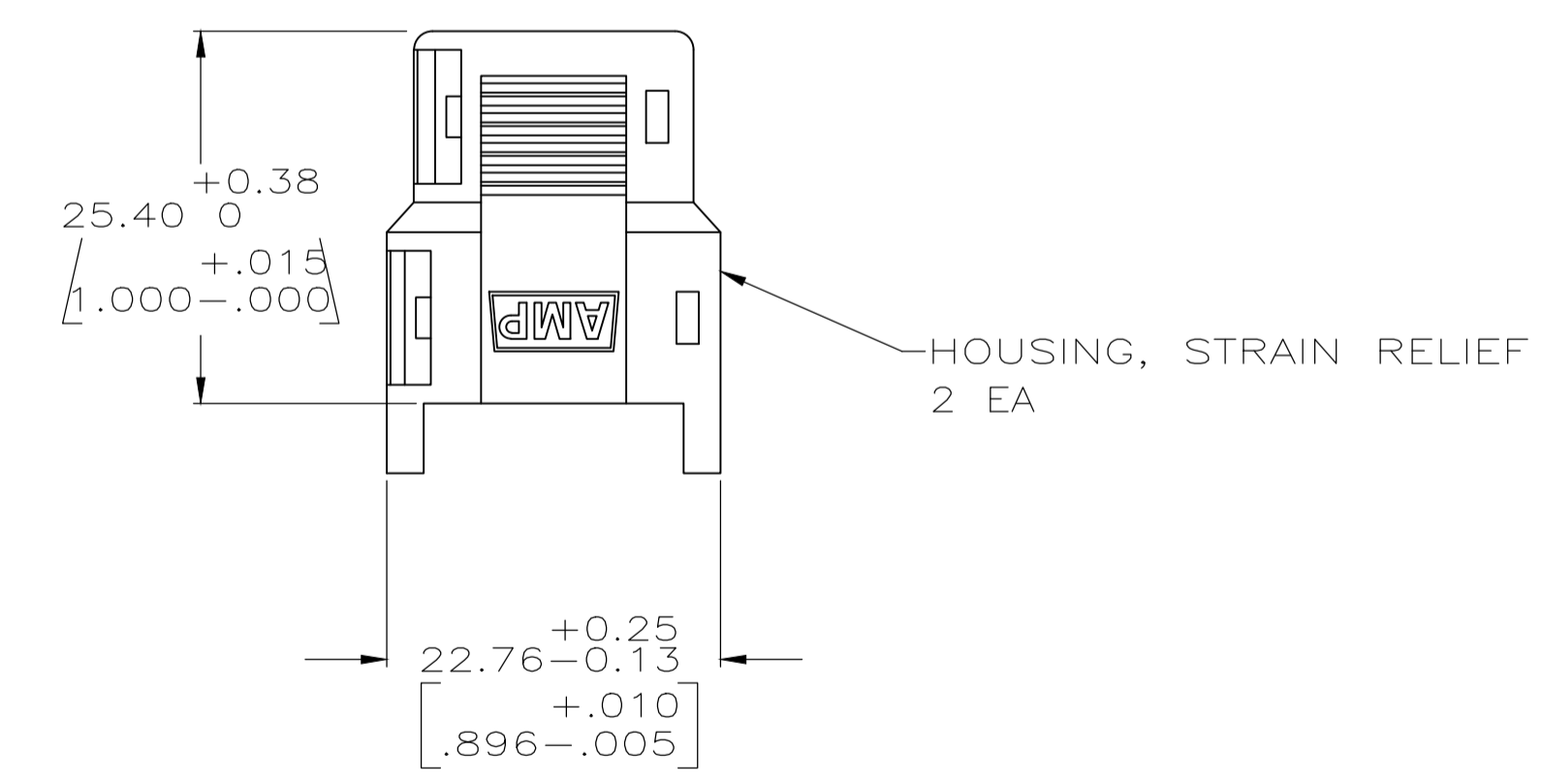
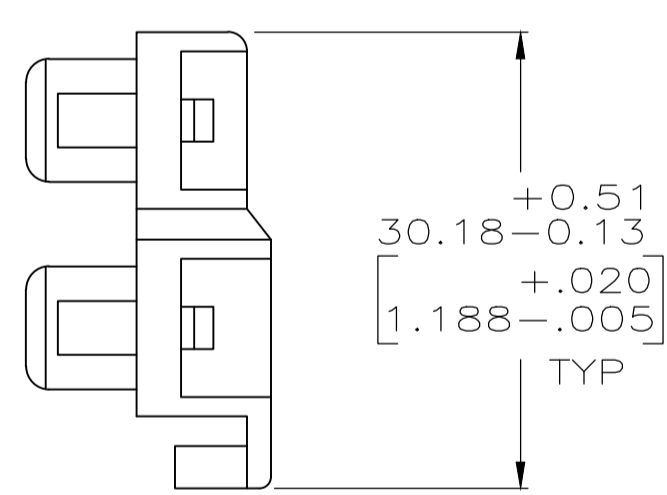
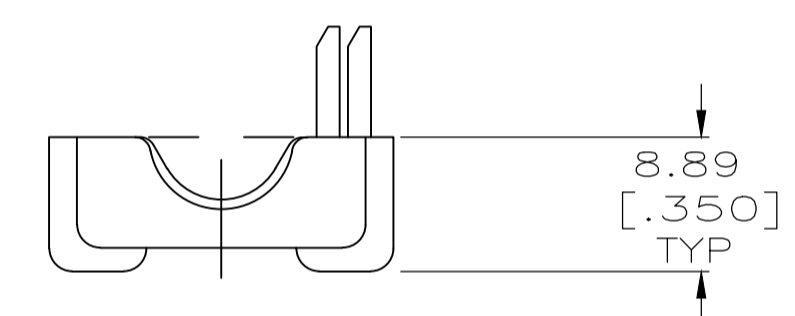
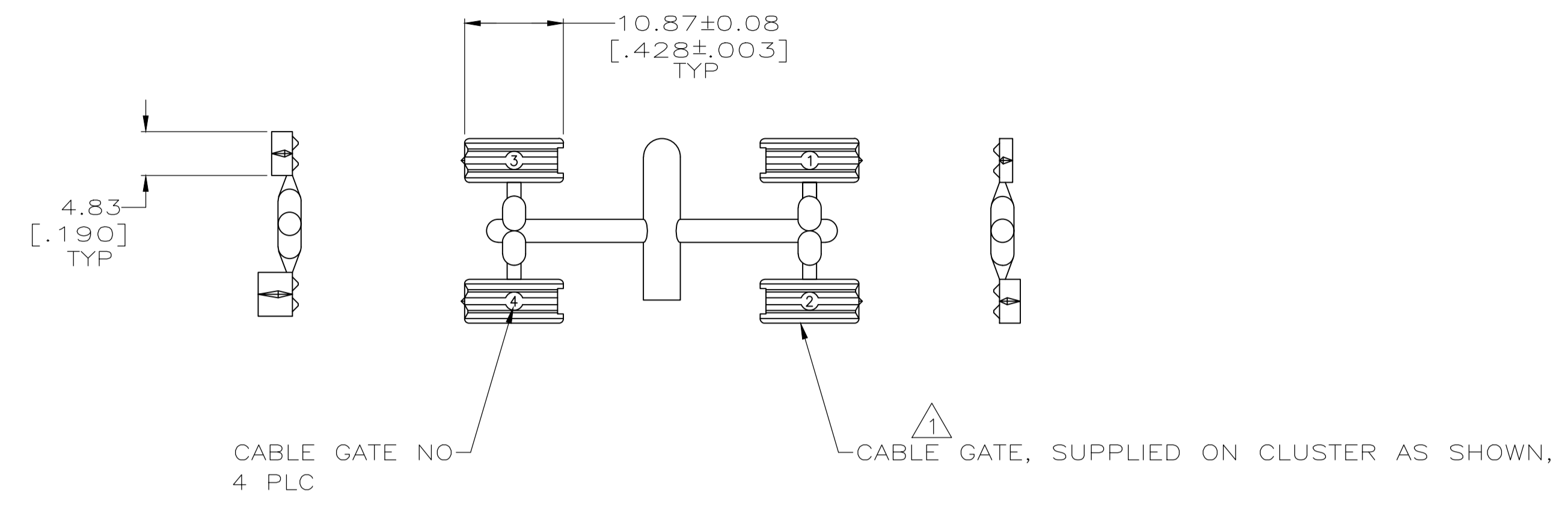

- ⚠ A VARIETY OF CABLE GATES ARE PROVIDED TO ACCOMMODATE A VARIETY OF CUSTOMER CABLE SIZES.
- ⚠ PLUG SHOWN FOR REFERENCE ONLY. STRAIN RELIEF CAN BE USED ON EITHER PLUG OR RECEPTACLE.
- ⚠ HOUSING MATERIAL: PA66, BLACK, UL 94 V-0 RATED.

207600-1  
PART NUMBER

THIS DRAWING IS A CONTROLLED DOCUMENT.		DIN J. McCLINTON 1-26-92	TE Connectivity	
DIMENSIONS: INCHES		CHK R. STONE 1-29-92	NAME	
TOLERANCES UNLESS OTHERWISE SPECIFIED:		APVD	PRODUCT SPEC	
0. PLC	± .005		108-10033	
1. PLC	± .005		APPLICATION SPEC	
2. PLC	± 0.13[.005]		SIZE	CAGE CODE DRAWING NO
3. PLC	± .005		A1	00779 C=207600
4. PLC	± .005		WEIGHT	
ANGLES	± .005		CUSTOMER DRAWING	SCALE 2:1 SHEET 1 OF 1 REV G
MATERIAL				
FINISH				