

# PI2DPX1066

## 1.8V 10Gbps USB-C DP-Alt Linear Redriver with AUX-SBU switch

### Features

- 4-to-4 channel configuration with 10Gbps linear Redriver
- Configurable for USB3.2 Gen2, USB3.2 Gen2/2-lane DP1.4/DP2.0 (UHBR10), 4-lane DP1.4/DP2.0 (UHBR10) or USB3.2 Gen2x2 operations
- Default USB Type-C safe state (Hi-Z) after power-on
- Ultra low latency (< 300ps) for better interoperability and data throughput
- Individual controls on CTLE gain, Flat Gain and Output linearity
- Integrated AUX channel crossbar switch for side band signal
- Type-C connector flip and non-flip plug support
- I2C Slave support with speed up to 1MHz
- Very low USB and DisplayPort active mode and power saving mode operation
- Single power supply: 1.8V +/-5%
- Industrial temperature support: -40°C to +85°C
- Totally Lead-Free & Fully RoHS Compliant (Notes 1 & 2)
- Halogen and Antimony Free. "Green" Device (Note 3)
- For automotive applications requiring specific change control (i.e. parts qualified to AEC-Q100/101/200, PPAP capable, and manufactured in IATF 16949 certified facilities), please [contact us](#) or your local Diodes representative.  
<https://www.diodes.com/quality/product-definitions/>
- Packaging (Pb-free & Green):
  - Tiny 32-pin X2QFN, (0.4 mm pitch) (XUA)

### Application Example

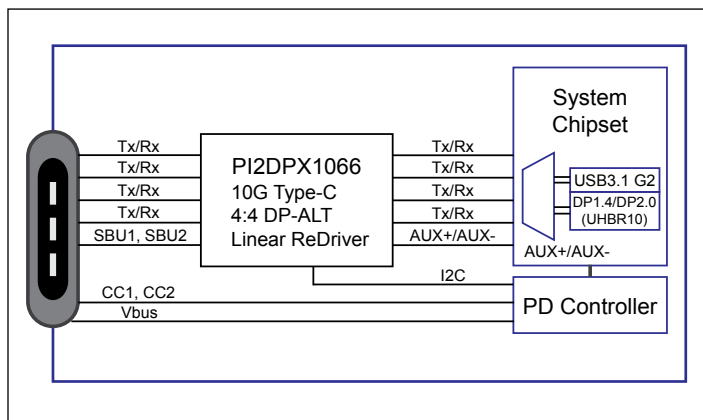

System with USB Type-C Connector Application

### Description

The PI2DPX1066 is a non-blocking USB Type-C DP-Alt mode linear Redriver™ in 4-to-4 configuration operated by 1.8v power supply. It supports four operation modes through I2C bus setting for USB3.2 Gen2, USB3.2 Gen2/2-lane DP1.4/DP2.0 (UHBR10), 4-lane DP1.4/DP2.0 (UHBR10) or USB3.2 Gen2x2 with speed up to 10Gbps per channel. It swaps the high speed channels under the flip and non-flip plug in compliance to Type-C connector with the integrated AUX crossbar switch for SBU pins.

The non-blocking linear Redriver design ensures the differential signals conveying pre-shoot and de-emphasis equalization waveforms from transmitter side to receiver side, this can help to optimize the overall channel link adjustment conducted by the system transmitter and receiver with DFE. The CTLE equalizers are implemented at the inputs of the Redriver to compensate the channel loss and reduce the ISI jitters. The programmable flat gain and linearity adjustments support the eye diagram opening.

The CTLE EQ gains, flat gains and linearity are individually programmable on each channel for flexible tuning via I2C register settings.

### Applications

- Laptop PCs
- Desktop PCs
- Gaming Consoles
- VR/AR Goggles
- Active Cables

### Ordering Information

Part Number	Package Code	Description
PI2DPX1066XUAEX	XUA	32-pin, 2.85x4.5mm (X2QFN)
PI2DPX1066XUAIEX	XUA	32-pin, 2.85x4.5mm (X2QFN)

#### Notes:

1. No purposely added lead. Fully EU Directive 2002/95/EC (RoHS), 2011/65/EU (RoHS 2) & 2015/863/EU (RoHS 3) compliant.
2. See <https://www.diodes.com/quality/lead-free/> for more information about Diodes Incorporated's definitions of Halogen- and Antimony-free, "Green" and Lead-free.
3. Halogen- and Antimony-free "Green" products are defined as those which contain <900ppm bromine, <900ppm chlorine (<1500ppm total Br + Cl) and <1000ppm antimony compounds.
4. I = Industrial Temp.
5. E = Pb-free and Green
6. X suffix = Tape/Reel