

ACPL-C78A, ACPL-C780, ACPL-C784

Miniature Isolation Amplifiers

Description

The Broadcom[®] ACPL-C78A/C780/C784 family of isolation amplifiers is designed for current sensing in electronic motor drives. In a typical implementation, motor currents flow through an external resistor and the resulting analog voltage drop is sensed by the ACPL-C78A/C780/C784. A differential output voltage is created on the other side of the ACPL-C78A/C780/C784 optical isolation barrier. This differential output voltage is proportional to the motor current and can be converted to a single-ended signal by using an op-amp as shown in the recommended application circuit. Since common-mode voltage swings of several hundred volts in tens of nanoseconds are common in modern switching inverter motor drives, the ACPL-C78A/C780/C784 is designed to ignore very high common-mode transient slew rates (of at least 10 kV/ μ s).

The high CMR capability of the ACPL-C78A/C780/C784 isolation amplifier provides the precision and stability needed to accurately monitor motor current in high noise motor control environments, providing for smoother control (less “torque ripple”) in various types of motor control applications.

The product can also be used for general analog signal isolation applications requiring high accuracy, stability, and linearity under similarly severe noise conditions. For general applications, we recommend the ACPL-C780 (gain tolerance of $\pm 3\%$) and the ACPL-C784 (gain tolerance of $\pm 5\%$). For precision applications Broadcom offers the

ACPL-C78A with part-to-part gain tolerance of $\pm 1\%$. The ACPL-C78A/C780/C784 utilizes sigma-delta (Σ - Δ) analog-to-digital converter technology, chopper stabilized amplifiers, and a fully differential circuit topology.

Together, these features deliver unequaled isolation-mode noise rejection, as well as excellent offset and gain accuracy and stability over time and temperature. This performance is delivered in a compact, auto-insertable, Stretched SO-8 (SSO-8) package that meets worldwide regulatory safety standards.

Features

- 15 kV/ μ s Common-Mode Rejection at $V_{CM} = 1000$ V
- Compact, Auto-Insertable Stretched SO-8 Package
- 0.00025 V/V/ $^{\circ}$ C Gain Drift vs. Temperature
- 0.3 mV Input Offset Voltage
- 100 kHz Bandwidth
- 0.004% Nonlinearity
- Worldwide Safety Approval: UL 1577 (5000 Vrms/1 min.), CSA and IEC/EN/DIN EN 60747-5-5
- Advanced Sigma-Delta (Σ - Δ) A/D Converter Technology
- Fully Differential Amplifier

Applications

- Motor Phase and Rail Current Sensing
- Inverter Current Sensing
- DC Bus Voltage Sensing
- General Purpose Current Sensing and Monitoring
- General Purpose Analog Signal Isolation

CAUTION! It is advised that normal static precautions be taken in handling and assembly of this component to prevent damage and/or degradation which may be induced by ESD. The components featured in this data sheet are not to be used in military or aerospace applications or environments.

Functional Diagram

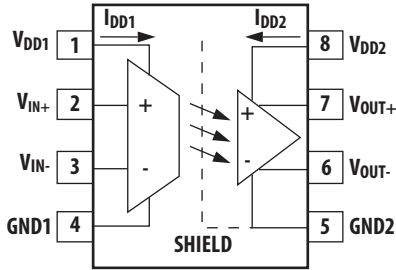

NOTE: A 0.1 μ F bypass capacitor must be connected between pins 1 and 4 and between pins 5 and 8.

Pin Description

Pin Number	Symbol	Description
1	V_{DD1}	Supply voltage for input side (4.5V to 5.5V), relative to GND1
2	V_{IN+}	Positive input (± 200 mV recommended)
3	V_{IN-}	Negative input (normally connected to GND1)
4	GND1	Input side ground
5	GND2	Output side ground
6	V_{OUT-}	Negative output
7	V_{OUT+}	Positive output
8	V_{DD2}	Supply voltage for output side (4.5V to 5.5V), relative to GND2

Ordering Information

ACPL-C78A/C780/C784 is UL-recognized with 5000 Vrms/1 minute rating per UL 1577.

Part Number	Option (RoHS Compliant)	Package	Surface Mount	Tape and Reel	IEC/EN/DIN EN 60747-5-5	Quantity
ACPL-C78A	-000E	Stretched SO-8	X	—	—	80 per tube
ACPL-C780	-060E		X	—	X	80 per tube
ACPL-C784	-500E		X	X	—	1000 per reel
	-560E		X	X	X	1000 per reel

To order, choose a part number from the part number column and combine with the desired option from the option column to form an order entry.

Example:

ACPL-C78A-560E to order product of Surface Mount package in Tape and Reel packaging with IEC/EN/DIN EN 60747-5-5 Safety Approval and RoHS compliance.

Option datasheets are available. Contact your Broadcom sales representative or authorized distributor for information.

Package Outline Drawings

Stretched SO-8 Package (SSO-8)

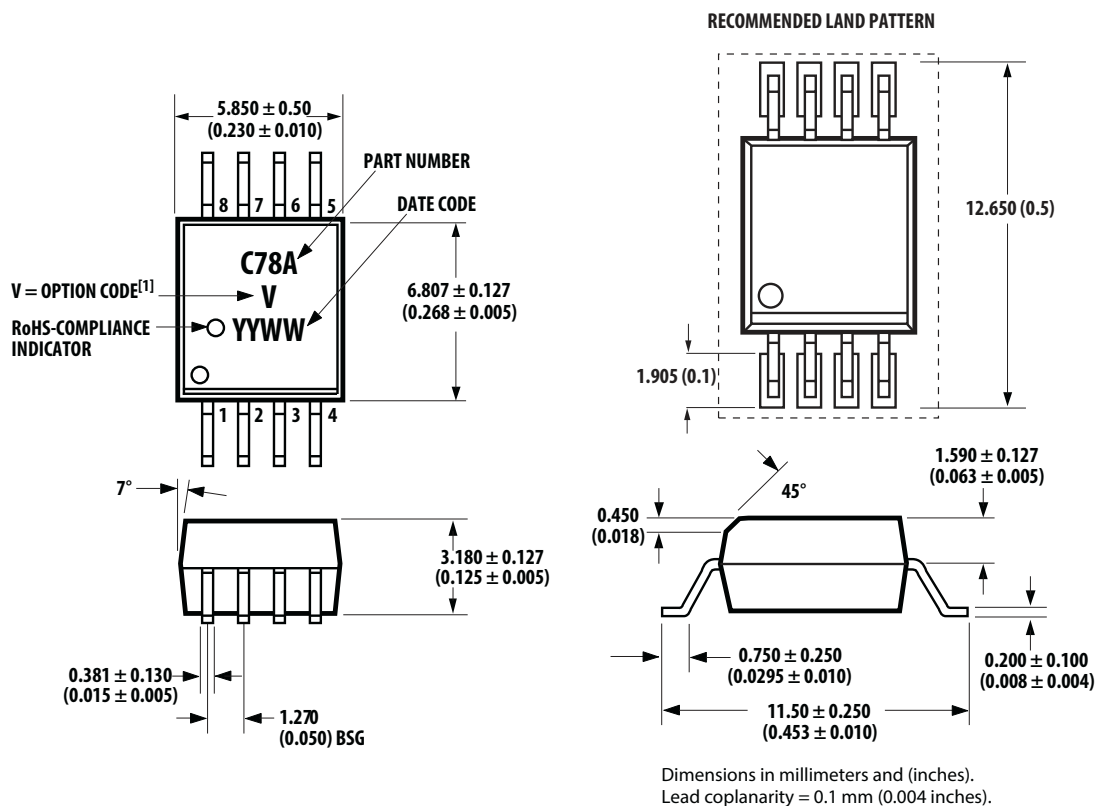

NOTE: 1: "V" = Is 060 or 560; other options are not marked.

Recommended PB-Free IR Profile

Recommended reflow condition as per JEDEC Standard, J-STD-020 (latest revision).

NOTE: Non-halide flux should be used.

Regulatory Information

The ACPL-C78A/C780/C784 is approved by the following organizations:

IEC/EN/DIN EN 60747-5-5

Approval with Maximum Working Insulation Voltage,
 $V_{IORM} = 1414V_{peak}$

UL

Approval under UL 1577, component recognition program up to
 $V_{ISO} = 5000V_{rms}$. File E55361.

CSA

Approval under CSA Component Acceptance Notice #5, File
CA 88324.

Insulation and Safety-Related Specifications

Parameter	Symbol	Value	Units	Conditions
Minimum External Air Gap (External Clearance)	L(101)	8.0	mm	Measured from input terminals to output terminals, shortest distance through air.
Minimum External Tracking (EXternal Creepage)	L(102)	8.0	mm	Measured from input terminals to output terminals, shortest distance path along body.
Minimum Internal Plastic Gap (Internal Clearance)		0.5	mm	Through insulation distance, conductor to conductor, usually the direct distance between the photoemitter and photodetector inside the optocoupler cavity.
Tracking Resistance (Comparative Tracking Index)	CTI	> 175	V	DIN IEC 112/VDE 0303 Part 1
Isolation Group		IIIa		Material Group (DIN VDE 0110, 1/89, Table 1)

IEC/EN/DIN EN 60747-5-5 Insulation Characteristics (Option 060)¹

Description	Symbol	Value	Units
Installation Classification per DIN VDE 0110/1.89, Table 1			
For rated mains voltage ≤ 150 Vrms		I-IV	
For rated mains voltage ≤ 300 Vrms		I-IV	
For rated mains voltage ≤ 450 Vrms		I-IV	
For rated mains voltage ≤ 600 Vrms		I-IV	
For rated mains voltage ≤ 1000 Vrms		I-III	
Climatic Classification		55/100/21	
Pollution Degree (DIN VDE 0110/1.89)		2	
Maximum Working Insulation Voltage	V_{IORM}	1414	V_{peak}
Input to Output Test Voltage, Method b $V_{IORM} \times 1.875 = V_{PR}$, 100% Production Test with $t_m = 1s$, Partial Discharge < 5 pC	V_{PR}	2652	V_{peak}
Input to Output Test Voltage, Method a $V_{IORM} \times 1.5 = V_{PR}$, Type and Sample Test, $t_m = 10s$, Partial Discharge < 5 pC	V_{PR}	2262	V_{peak}
Highest Allowable Overvoltage (Transient Overvoltage $t_{ini} = 60s$)	V_{IOTM}	8000	V_{peak}
Safety-Limiting Values – maximum values allowed in the event of a failure			
Case Temperature	T_S	175	°C
Input Current ^a	$I_{S,INPUT}$	230	mA
Output Power ^a	$P_{S,OUTPUT}$	600	mW
Insulation Resistance at T_S , $V_{IO} = 500V$	R_S	$\geq 10^9$	Ω

a. Safety-limiting parameters are dependent on ambient temperature. The Input Current, $I_{S,INPUT}$, derates linearly above 25°C free-air temperature at a rate of 2.53 mA/°C; the Output Power, $P_{S,OUTPUT}$, derates linearly above 25°C free-air temperature at a rate of 4 mW/°C.

- Insulation characteristics are guaranteed only within the safety maximum ratings, which must be ensured by protective circuits within the application.

Absolute Maximum Rating

Parameter	Symbol	Min.	Max.	Units	Note
Storage Temperature	T_S	-55	+125	°C	
Ambient Operating Temperature	T_A	-40	+100	°C	
Supply Voltages	V_{DD1}, V_{DD2}	0	5.5	V	
Steady-State Input Voltage	V_{IN+}, V_{IN-}	-2	$V_{DD1} + 0.5$	V	
Two Second Transient Input Voltage	V_{IN+}, V_{IN-}	-6	—	V	
Output Voltages	V_{OUT+}, V_{OUT-}	-0.5	$V_{DD2} + 0.5$	V	
Lead Solder Temperature	260°C for 10 seconds, 1.6 mm below seating plane				a

a. Non-halide flux should be used.

Recommended Operating Conditions

Parameter	Symbol	Min.	Max.	Units	Note
Ambient Operating Temperature	T_A	-40	+85	°C	
Supply Voltages	V_{DD1}, V_{DD2}	4.5	5.5	V	
Input Voltage (linear and accurate)	V_{IN+}, V_{IN-}	-200	+200	mV	1
Input Voltage (functional)	V_{IN+}, V_{IN-}	-2	2	V	

DC Electrical Specifications

Unless otherwise noted, all typicals and figures are at the nominal operating conditions of $V_{IN+} = 0V$, $V_{IN-} = 0V$, $V_{DD1} = V_{DD2} = 5V$ and $T_A = 25^\circ C$; all minimum/maximum specifications are within the recommended operating conditions.

Parameter	Symbol	Min.	Typ.	Max.	Units	Test Conditions	Figure	Notes
Input Offset Voltage	V_{OS}	-2	0.3	2	mV	$T_A = 25^\circ C$	1, 2, 3	
Input Offset Voltage	V_{OS}	-3	—	3	mV	$T_A = -40^\circ C$ to $+85^\circ C$	1, 2, 3	
Magnitude of Input Offset Change vs. Temperature	$ dV_{OS}/dT_A $	—	3	10	$\mu V/^\circ C$	—	2	2
Gain (ACPL-C78A, $\pm 1\%$)	G1	7.92	8	8.08	V/V	$V_{IN+} = -200$ mV to $+200$ mV, $T_A = 25^\circ C$	4, 5, 6	3
Gain (ACPL-C780, $\pm 3\%$)	G3	7.76	8	8.24	V/V	$V_{IN+} = -200$ mV to $+200$ mV, $T_A = 25^\circ C$	4, 5, 6	3
Gain (ACPL-C784, $\pm 5\%$)	G5	7.6	8	8.4	V/V	$V_{IN+} = -200$ mV to $+200$ mV, $T_A = 25^\circ C$	4, 5, 6	3
Magnitude of V_{OUT} Gain Change vs. Temperature	$ dG/dT_A $	—	0.00025	—	V/V/ $^\circ C$	—	4, 5, 6	4
V_{OUT} Nonlinearity over ± 200 mV Input Voltage	NL ₂₀₀	—	0.0037	0.35	%	$V_{IN+} = -200$ mV to $+200$ mV	7, 8	5
Magnitude of NL ₂₀₀ Change vs. Temperature	$ dNL_{200}/dT_A $	—	0.0002	—	%/ $^\circ C$	—	7, 8	5
V_{OUT} Nonlinearity over ± 100 mV Input Voltage	NL ₁₀₀	—	0.0027	0.2	%	$V_{IN+} = -100$ mV to $+100$ mV	7, 8	6
Maximum Input Voltage before V_{OUT} Clipping	$ V_{IN+} _{MAX}$	—	308	—	mV	—	9	
Input Side Supply Current	I_{DD1}	—	11	16	mA	$V_{IN+} = +400$ mV	10	7
Output Side Supply Current	I_{DD2}	—	13	16	mA	$V_{IN+} = -400$ mV	10	8
Input Current	I_{IN+}	-5	-0.5	—	μA	$V_{IN+} = 0V$, $V_{IN-} = 0V$	11	9
Magnitude of Input Bias Current vs. Temperature	$ dI_{IN}/dT_A $	—	0.45	—	nA/ $^\circ C$	—		
Output Low Voltage	V_{OL}	—	1.29	—	V	—	9	10
Output High Voltage	V_{OH}	—	3.8	—	V	—	9	10
V_{OUT} Output Common-Mode Voltage	V_{OCM}	2.2	2.545	2.8	V	—		
V_{OUT} Output Short-Circuit Current	$ I_{OSCL} $	—	18.6	—	mA	$V_{OUT} = 0V$ or V_{DD2}		11
Equivalent Input Impedance	R_{IN}	—	500	—	k Ω	—		9
V_{OUT} Output Resistance	R_{OUT}	—	15	—	Ω	—		
Input DC Common-Mode Rejection Ratio	CMRR _{IN}	—	76	—	dB	—		12

AC Electrical Specifications

Unless otherwise noted, all typicals and figures are at the nominal operating conditions of $V_{IN+} = 0V$, $V_{IN-} = 0V$, $V_{DD1} = V_{DD2} = 5V$ and $T_A = 25^\circ C$; all minimum/maximum specifications are within the recommended operating conditions.

Parameter	Symbol	Min.	Typ.	Max.	Units	Test Conditions	Figure	Notes
Small-Signal Bandwidth (-3 dB)	$f_{-3\text{dB}}$	50	100	—	kHz	$V_{IN+} = 200\text{ mVpk-pk sine wave}$	12, 13	
RMS V_{OUT} Noise	V_N	—	31.5	—	mVrms	$V_{IN+} = 0V$		13
V_{IN} to V_{OUT} Signal Delay (50 – 10%)	t_{PD10}	—	2.03	3.3	μs	$V_{IN+} = 0$ to 150 mV step, measured at V_{OUT} node in Figure 15	14, 15	
V_{IN} to V_{OUT} Signal Delay (50 – 50%)	t_{PD50}	—	3.47	5.6	μs	$V_{IN+} = 0$ to 150 mV step, measured at V_{OUT} node in Figure 15	14, 15	
V_{IN} to V_{OUT} Signal Delay (50 – 90%)	t_{PD90}	—	4.99	9.9	μs	$V_{IN+} = 0$ to 150 mV step, measured at V_{OUT} node in Figure 15	14, 15	
V_{OUT} Rise/Fall Time (10 – 90%)	$t_{R/F}$	—	2.96	6.6	μs	$V_{IN+} = 0$ to 150 mV step, measured at V_{OUT} node in Figure 15	14, 15	
Common Mode Transient Immunity	CMTI	10	15	—	kV/ μs	$V_{CM} = 1\text{ kV}$, $T_A = 25^\circ C$	16	14
Power Supply Rejection	PSR	—	170	—	mVrms	—		15

Package Characteristics

Parameter	Symbol	Min.	Typ.	Max.	Units	Test Conditions	Figure	Notes
Input-Output Momentary Withstand Voltage	V_{ISO}	5000	—	—	V_{RMS}	$RH \leq 50\%$, $t = 1\text{ minute}$, $T_A = 25^\circ C$		16, 17
Resistance (Input-Output)	R_{I-O}	—	$>10^{12}$	—	Ω	$V_{I-O} = 500V_{DC}$		18
Capacitance (Input-Output)	C_{I-O}	—	0.5	—	pF	$f = 1\text{ MHz}$		18

Notes

General Note: Typical values represent the mean value of all characterization units at the nominal operating conditions. Typical drift specifications are determined by calculating the rate of change of the specified parameter versus the drift parameter (at nominal operating conditions) for each characterization unit, and then averaging the individual unit rates. The corresponding drift figures are normalized to the nominal operating conditions and show how much drift occurs as the particular drift parameter is varied from its nominal value, with all other parameters held at their nominal operating values. Note that the typical drift specifications in the tables may differ from the slopes of the mean curves shown in the corresponding figures.

1. It is recommended to operate with $V_{IN-} = 0V$ (tied to GND1). Limiting V_{IN+} to 100 mV will improve DC nonlinearity and nonlinearity drift. If V_{IN-} is brought above $V_{DD1} - 2V$, an internal test mode may be activated. This test mode is for LED coupling test and is not intended for customer use.
2. This is the Absolute Value of Input Offset Change vs. Temperature.
3. Gain is defined as the slope of the best-fit line of differential output voltage ($V_{OUT+} - V_{OUT-}$) vs. differential input voltage ($V_{IN+} - V_{IN-}$) over the specified input range.
4. This is the Absolute Value of Gain Change vs. Temperature.
5. Nonlinearity is defined as half of the peak-to-peak output deviation from the best-fit gain line, expressed as a percentage of the full-scale differential output voltage.
6. NL_{100} is the nonlinearity specified over an input voltage range of ± 100 mV.
7. The input supply current decreases as the differential input voltage ($V_{IN+} - V_{IN-}$) decreases.
8. The maximum specified output supply current occurs when the differential input voltage ($V_{IN+} - V_{IN-}$) = -200 mV, the maximum recommended operating input voltage. However, the output supply current will continue to rise for differential input voltages up to approximately -300 mV, beyond which the output supply current remains constant.
9. Because of the switched-capacitor nature of the input sigma-delta converter, time-averaged values are shown.
10. When the differential input signal exceeds approximately 308 mV, the outputs will limit at the typical values shown.
11. Short circuit current is the amount of output current generated when either output is shorted to V_{DD2} or GND2.
12. CMRR is defined as the ratio of the differential signal gain (signal applied differentially between pins 2 and 3) to the common-mode gain (input pins tied together and the signal applied to both inputs at the same time), expressed in dB.
13. Output noise comes from two primary sources: chopper noise and sigma-delta quantization noise. Chopper noise results from chopper stabilization of the output op-amps. It occurs at a specific frequency (typically 400 kHz at room temperature), and is not attenuated by the internal output filter. A filter circuit can be easily added to the external post-amplifier to reduce the total RMS output noise. The internal output filter does eliminate most, but not all, of the sigma-delta quantization noise. The magnitude of the output quantization noise is very small at lower frequencies (below 10 kHz) and increases with increasing frequency.
14. CMTI (Common Mode Transient Immunity or CMR, Common Mode Rejection) is tested by applying an exponentially rising/falling voltage step on pin 4 (GND1) with respect to pin 5 (GND2). The rise time of the test waveform is set to approximately 50 ns. The amplitude of the step is adjusted until the differential output ($V_{OUT+} - V_{OUT-}$) exhibits more than a 200 mV deviation from the average output voltage for more than 1 μ s. The ACPL-C78A/C780/C784 will continue to function if more than 10 kV/ μ s common mode slopes are applied, as long as the breakdown voltage limitations are observed.
15. Data sheet value is the differential amplitude of the transient at the output of the ACPL-C78A/C780/C784 when a 1 Vpk-pk, 1 MHz square wave with 40 ns rise and fall times is applied to both V_{DD1} and V_{DD2} .
16. In accordance with UL 1577, each optocoupler is proof tested by applying an insulation test voltage ≥ 6000 Vrms for 1 second (leakage detection current limit, $I_{L-O} \leq 5 \mu A$). This test is performed before the 100% production test for partial discharge (method b) shown in IEC/EN/DIN EN 60747-5-5 Insulation Characteristic Table.

17. The Input-Output Momentary Withstand Voltage is a dielectric voltage rating that should not be interpreted as an input-output continuous voltage rating. For the continuous voltage rating, refer to the IEC/EN/DIN EN 60747-5-5 insulation characteristics table and your equipment level safety specification.
18. This is a two-terminal measurement: pins 1–4 are shorted together and pins 5–8 are shorted together.

Figure 1: Input Offset Voltage Test Circuit

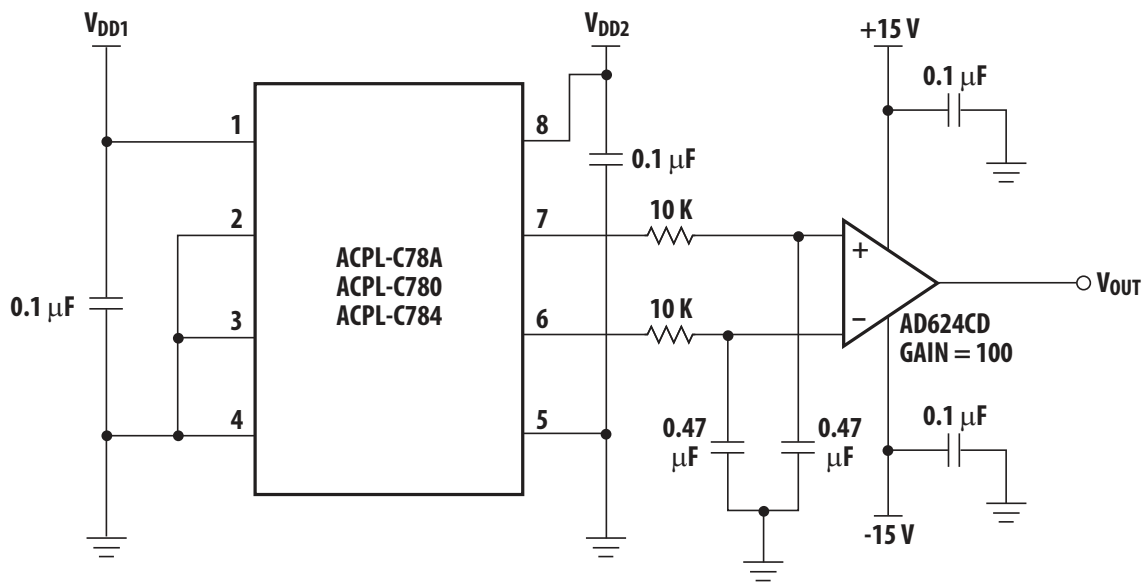

Figure 2: Input Offset Voltage vs. Temperature

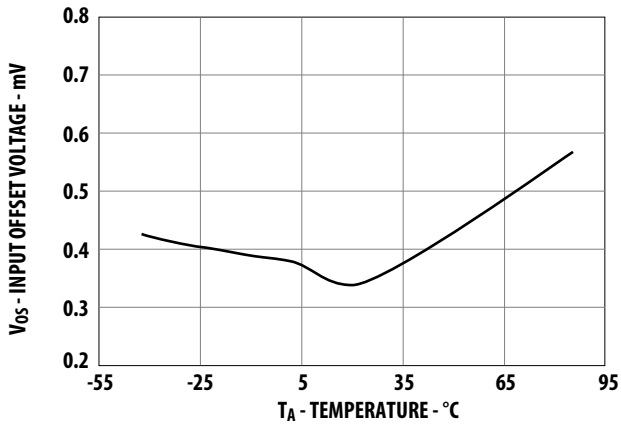

Figure 3: Input Offset Voltage vs. Supply Voltage

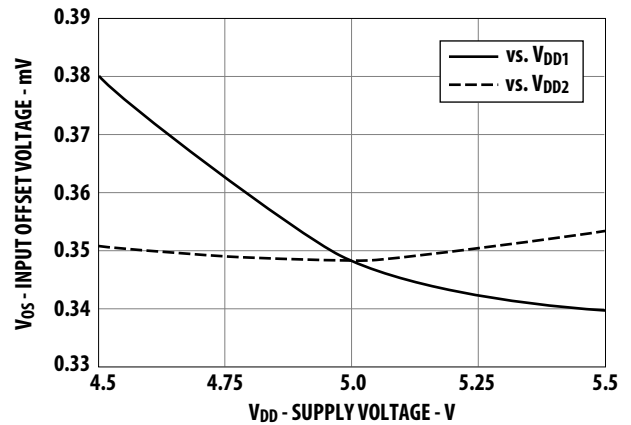

Figure 4: Gain vs. Temperature

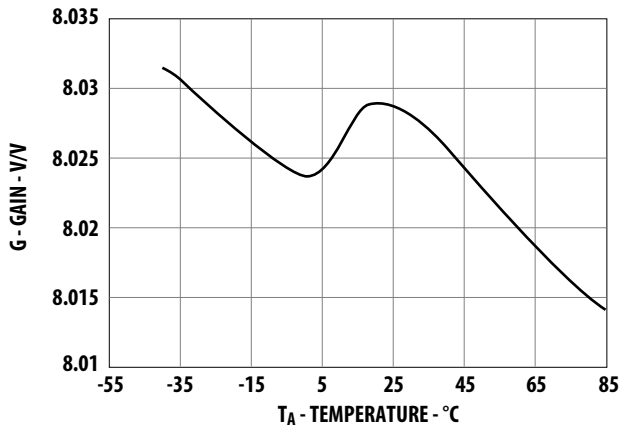

Figure 5: Gain and Nonlinearity Test Circuit

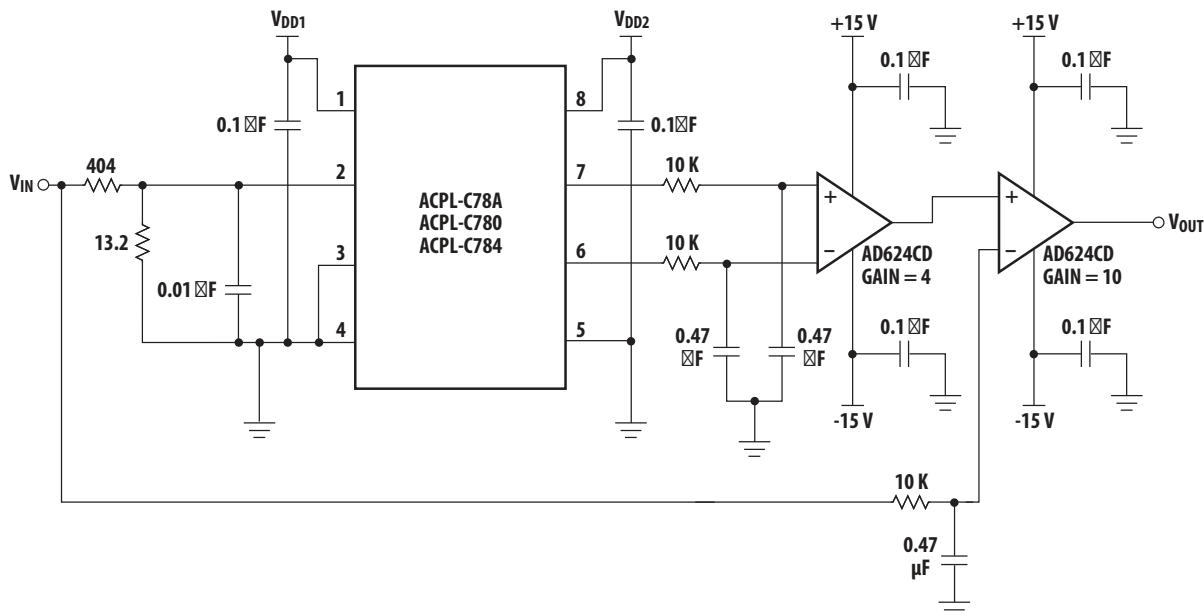

Figure 6: Gain vs. Supply Voltage

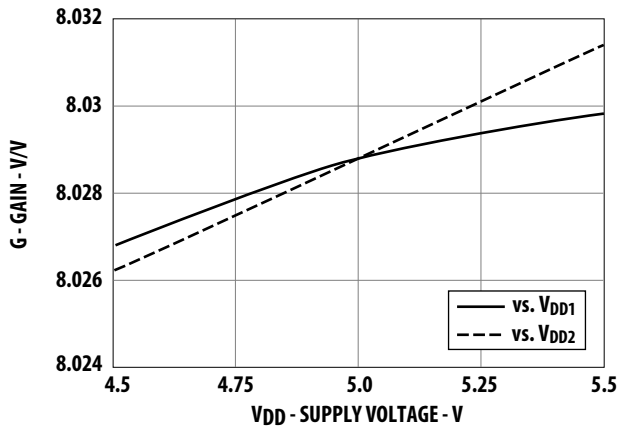

Figure 7: Nonlinearity vs. Temperature

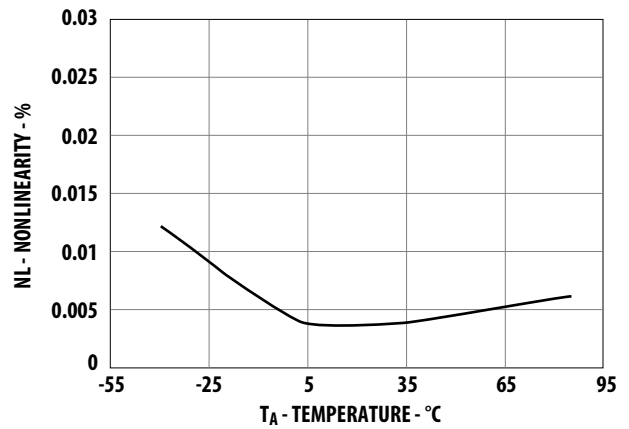

Figure 8: Nonlinearity vs. Supply Voltage

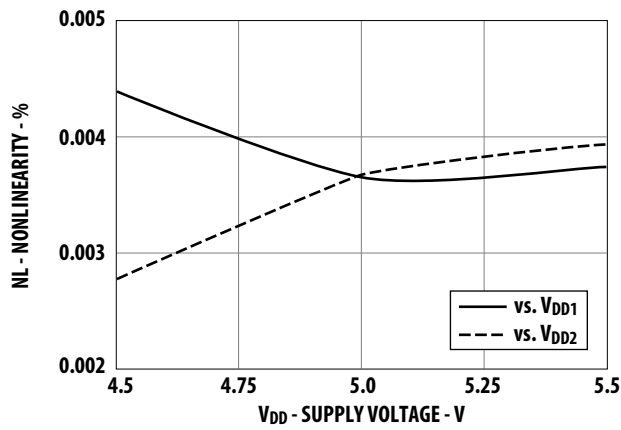

Figure 9: Output Voltage vs. Input Voltage

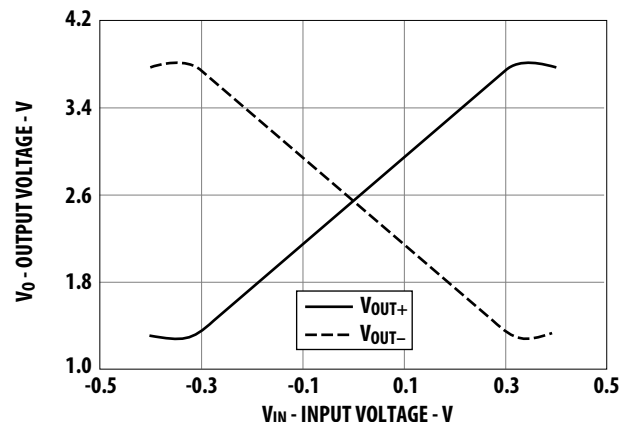

Figure 10: Supply Current vs. Input Voltage

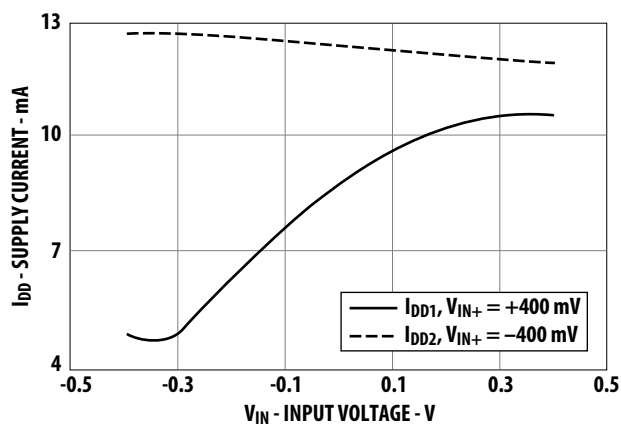

Figure 11: Input Current vs. Input Voltage

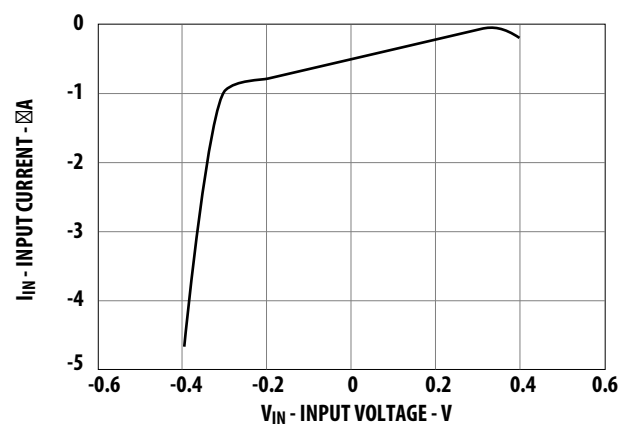

Figure 12: Gain vs. Frequency

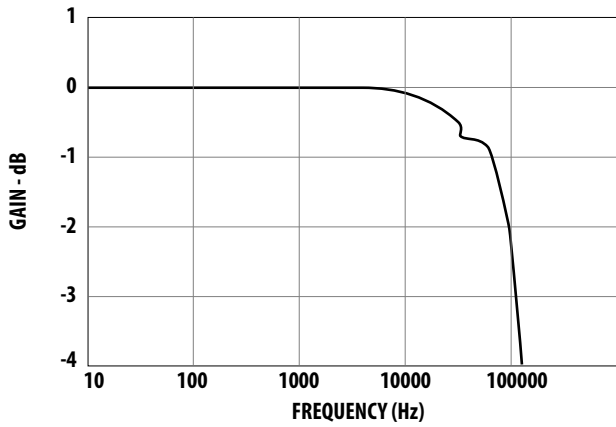

Figure 13: Phase vs. Frequency

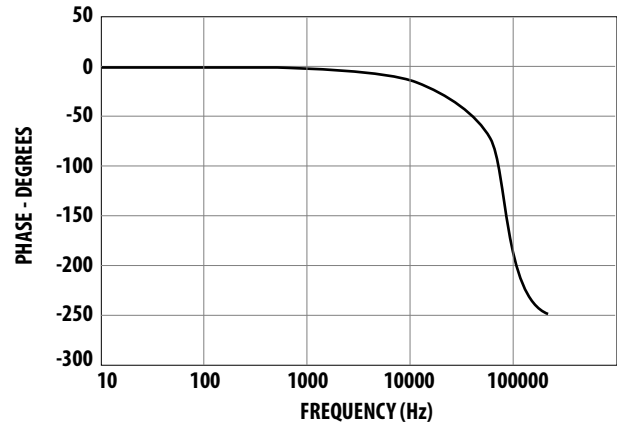

Figure 14: Propagation Delay vs. Temperature

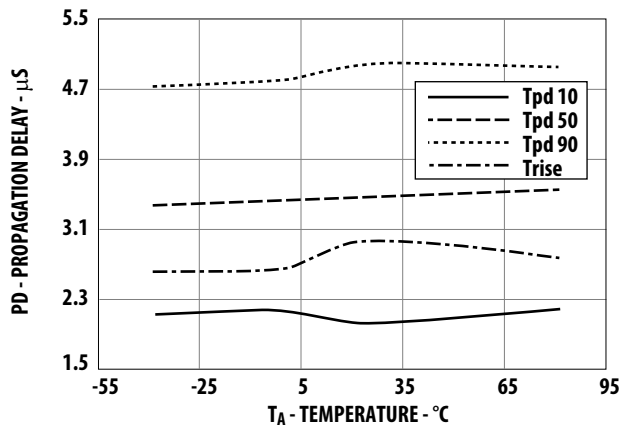
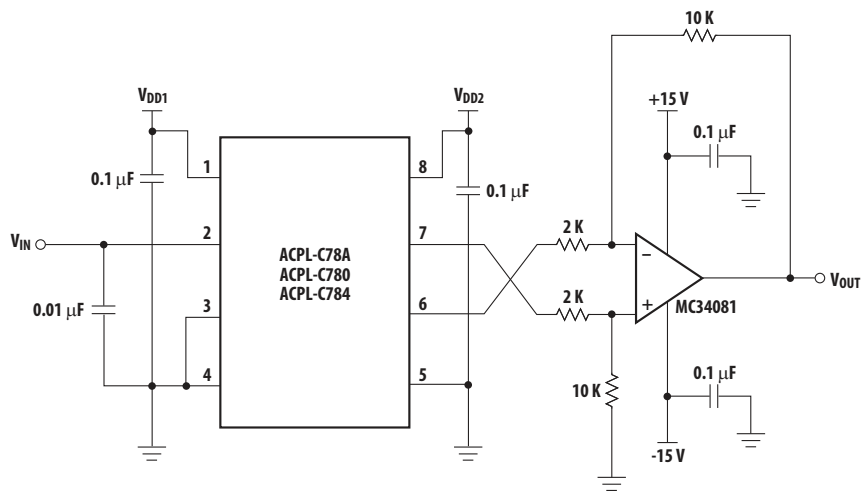
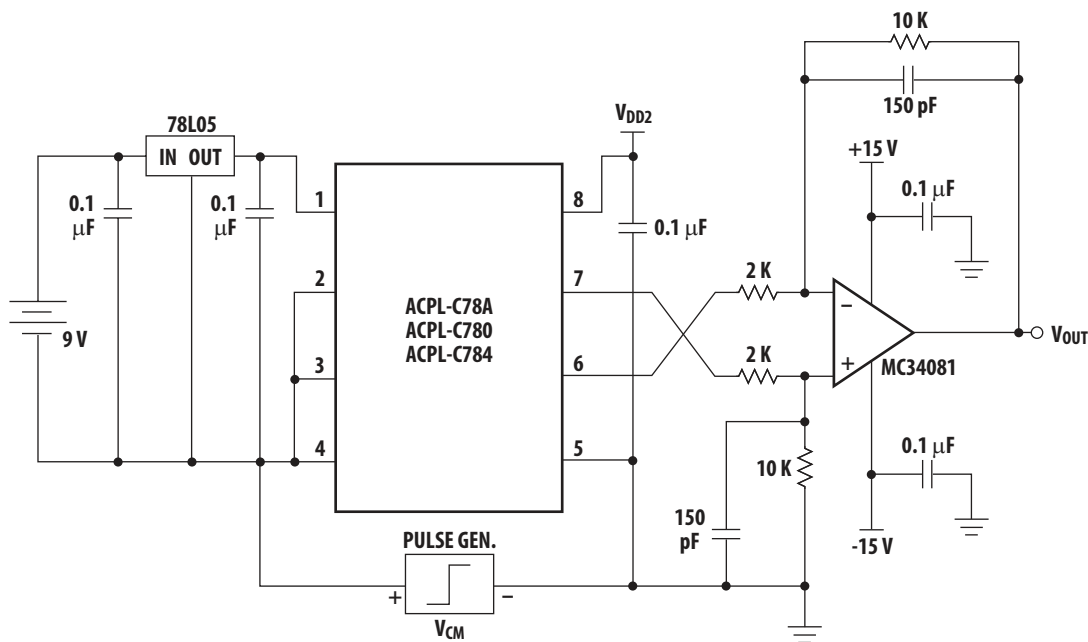

Figure 15: Propagation Delay Test Circuits



V_{IN} IMPEDANCE LESS THAN 10 Ω.

Figure 16: CMTI Test Circuits



Application Information

Power Supplies and Bypassing

The recommended supply connections are shown in [Figure 17](#). A floating power supply (which in many applications could be the same supply that is used to drive the high-side power transistor) is regulated to 5V using a simple zener diode (D1); the value of resistor R4 should be chosen to supply sufficient current from the existing floating supply. The voltage from the current sensing resistor (R_{sense}) is applied to the input of the ACPL-C78A/C780/C784 through an RC anti-aliasing filter (R2 and C2). Although the application circuit is relatively simple, a few recommendations should be followed to ensure optimal performance.

The power supply for the ACPL-C78A/C780/C784 is most often obtained from the same supply used to power the power transistor gate drive circuit. If a dedicated supply is required, in many cases it is possible to add an additional winding on an existing transformer. Otherwise, some sort of simple isolated supply can be used, such as a line powered transformer or a high-frequency DC-DC converter.

An inexpensive 78L05 three-terminal regulator can also be used to reduce the floating supply voltage to 5V. To help attenuate high-frequency power supply noise or ripple, a resistor or inductor can be used in series with the input of the regulator to form a low-pass filter with the regulator's input bypass capacitor.

As shown in [Figure 18](#), 0.1 μF bypass capacitors (C1, C2) should be located as close as possible to the pins of the ACPL-C78A/C780/C784. The bypass capacitors are required because of the high-speed digital nature of the signals inside the ACPL-C78A/C780/C784. A 0.01 μF bypass capacitor (C2) is also recommended at the input due to the switched-capacitor nature of the input circuit. The input bypass capacitor also forms part of the anti-aliasing filter, which is recommended to prevent high-frequency noise from aliasing down to lower frequencies and interfering with the input signal. The input filter also performs an important reliability function – it reduces transient spikes from ESD events flowing through the current sensing resistor.

PC Board Layout

The design of the printed circuit board (PCB) should follow good layout practices, such as keeping bypass capacitors close to the supply pins, keeping output signals away from input signals, the use of ground and power planes, etc. In addition, the layout of the PCB can also affect the isolation transient immunity (CMTI) of the ACPL-C78A/C780/C784, due primarily to stray capacitive coupling between the input and the output circuits. To obtain optimal CMTI performance, the layout of the PC board should minimize any stray coupling by maintaining the maximum possible distance between the input and output sides of the circuit and ensuring that any ground or power plane on the PC board does not pass directly below or extend much wider than the body of the ACPL-C78A/C780/C784.

Figure 17: Recommended Supply and Sense Resistor Connections

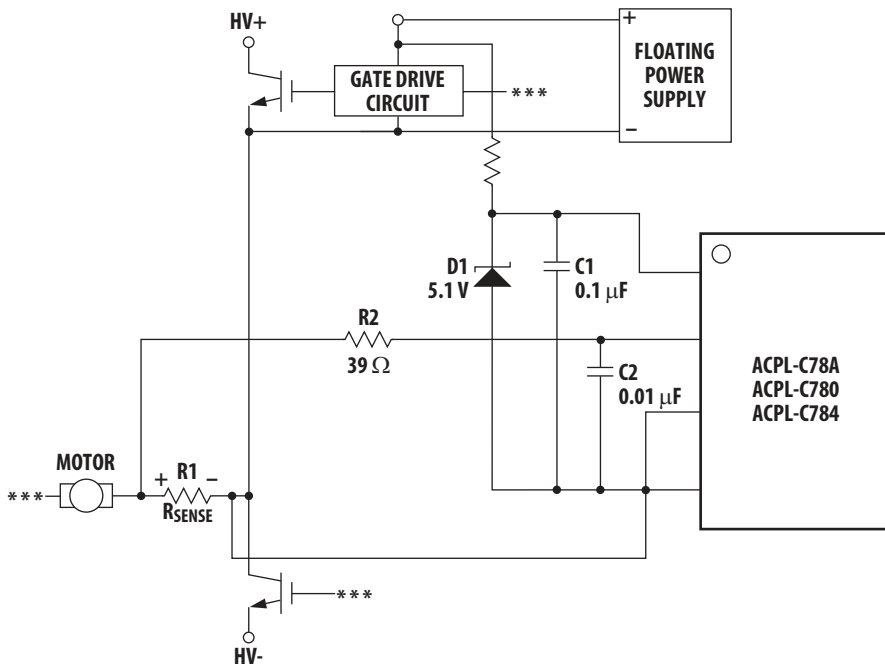

Figure 18: Recommended Application Circuit

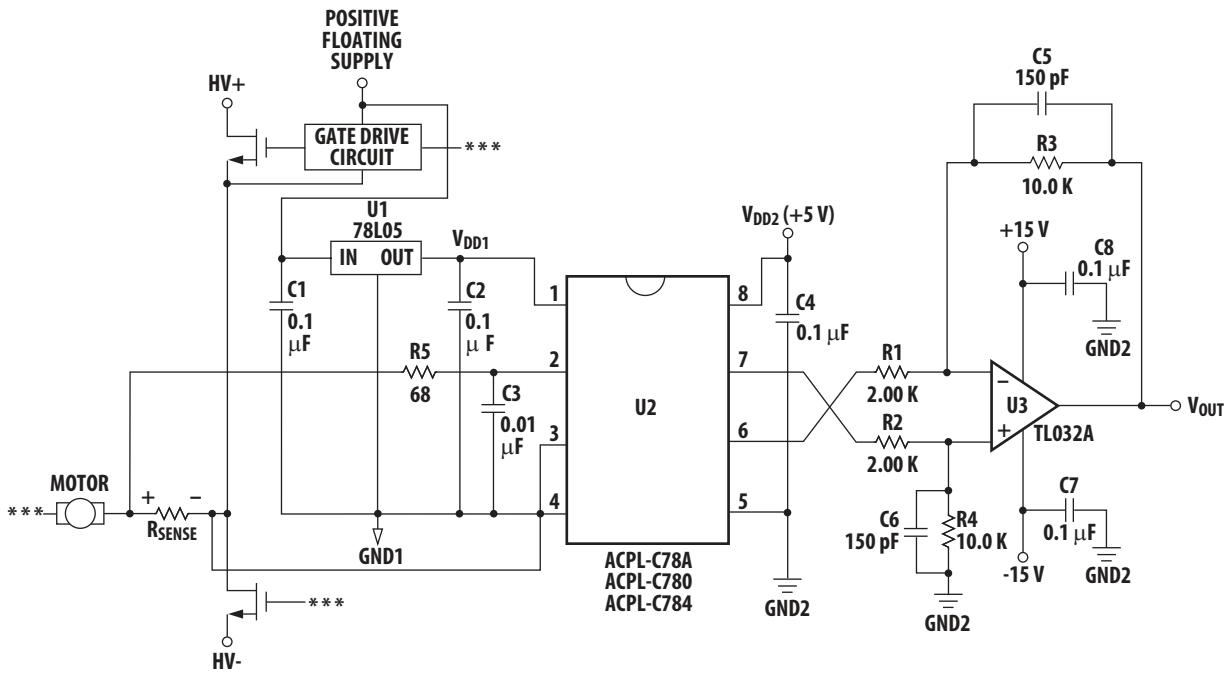
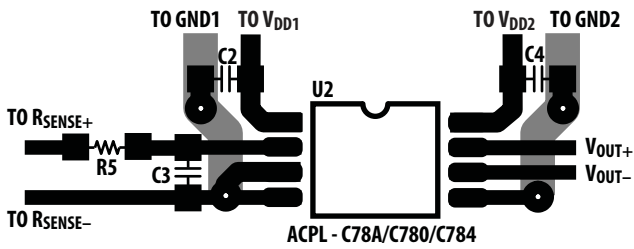

Figure 19: Example Printed Circuit Board Layout



Note: Drawing not to scale

Current Sensing Resistors

The current sensing resistor should have low resistance (to minimize power dissipation), low inductance (to minimize di/dt induced voltage spikes which could adversely affect operation), and reasonable tolerance (to maintain overall circuit accuracy). Choosing a particular value for the resistor is usually a compromise between minimizing power dissipation and maximizing accuracy. Smaller sense resistance decreases power dissipation, while larger sense resistance can improve circuit accuracy by utilizing the full input range of the ACPL-C78A/C780/C784.

The first step in selecting a sense resistor is determining how much current the resistor will be sensing. The graph in [Figure 20](#) shows the RMS current in each phase of a three-phase induction motor as a function of average motor output power (in horsepower, hp) and motor drive supply voltage. The maximum value of the sense resistor is determined by the current being measured and the maximum recommended input voltage of the isolation amplifier. The maximum sense resistance can be calculated by taking the maximum recommended input voltage and dividing by the peak current that the sense resistor should see during normal operation. For example, if a motor will have a maximum RMS current of 10 A and can experience up to 50% overloads during normal operation, then the peak current is 21.1A ($= 10 \times 1.414 \times 1.5$). Assuming a maximum input voltage of 200 mV, the maximum value of sense resistance in this case would be about 10 m Ω .

Figure 20: Motor Output Horsepower vs. Motor Phase Current and Supply Voltage

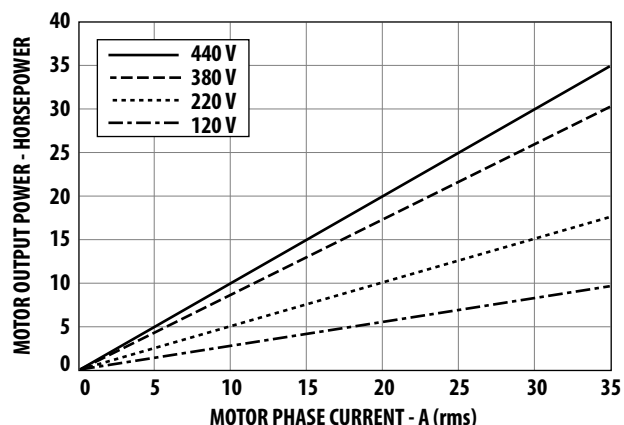

The maximum average power dissipation in the sense resistor can also be easily calculated by multiplying the sense resistance times the square of the maximum RMS current, which is about 1W in the previous example. If the power dissipation in the sense resistor is too high, the resistance can be decreased below the maximum value to decrease power dissipation. The minimum value of the sense resistor is limited by precision and accuracy requirements of the design. As the resistance value is reduced, the output voltage across the resistor is also reduced, which means that the offset and noise, which are fixed, become a larger percentage of the signal amplitude. The selected value of the sense resistor will fall somewhere between the minimum and maximum values, depending on the particular requirements of a specific design.

When sensing currents large enough to cause significant heating of the sense resistor, the temperature coefficient (tempco) of the resistor can introduce nonlinearity due to the signal dependent temperature rise of the resistor. The effect increases as the resistor-to-ambient thermal resistance increases. This effect can be minimized by reducing the thermal resistance of the current sensing resistor or by using a resistor with a lower tempco. Lowering the thermal resistance can be accomplished by repositioning the current sensing resistor on the PC board, by using larger PC board traces to carry away more heat, or by using a heat sink.

For a two-terminal current sensing resistor, as the value of resistance decreases, the resistance of the leads become a significant percentage of the total resistance. This has two primary effects on resistor accuracy. First, the effective resistance of the sense resistor can become dependent on factors such as how long the leads are, how they are bent, how far they are inserted into the board, and how far solder wicks up the leads during assembly (these issues will be discussed in more detail shortly). Second, the leads are typically made from a material, such as copper, which has a much higher tempco than the material from which the resistive element itself is made, resulting in a higher tempco overall.

Both of these effects are eliminated when a four-terminal current sensing resistor is used. A four-terminal resistor has two additional terminals that are Kelvin connected directly across the resistive element itself; these two terminals are used to monitor the voltage across the resistive element

while the other two terminals are used to carry the load current. Because of the Kelvin connection, any voltage drops across the leads carrying the load current should have no impact on the measured voltage.

When laying out a PC board for the current sensing resistors, a couple of points should be kept in mind. The Kelvin connections to the resistor should be brought together under the body of the resistor and then run very close to each other to the input of the ACPL-C78A/C780/C784; this minimizes the loop area of the connection and reduces the possibility of stray magnetic fields from interfering with the measured signal. If the sense resistor is not located on the same PC board as the ACPL-C78A/C780/C784 circuit, a tightly twisted pair of wires can accomplish the same thing.

Also, multiple layers of the PC board can be used to increase current carrying capacity. Numerous plated-through vias should surround each non-Kelvin terminal of the sense resistor to help distribute the current between the layers of the PC board. The PC board should use 2 or 4 oz. copper for the layers, resulting in a current carrying capacity in excess of 20A. Making the current carrying traces on the PC board fairly large can also improve the sense resistor's power dissipation capability by acting as a heat sink. Liberal use of vias where the load current enters and exits the PC board is also recommended.

NOTE: Please refer to Broadcom Application Note 1078 for additional information on using Isolation Amplifiers.

Sense Resistor Connections

The recommended method for connecting the ACPL-C78A/C780/C784 to the current sensing resistor is shown in [Figure 18](#). V_{IN+} (pin 2 of the ACPL-C78A/C780/C784) is connected to the positive terminal of the sense resistor, while V_{IN-} (pin 3) is shorted to GND1 (pin 4), with the power-supply return path functioning as the sense line to the negative terminal of the current sense resistor. This allows a single pair of wires or PC board traces to connect the ACPL-C78A/C780/C784 circuit to the sense resistor. By referencing the input circuit to the negative side of the sense resistor, any load current induced noise transients on the resistor are seen as a common-mode signal and will not interfere with the current-sense signal. This is important because the large load currents flowing through the motor drive, along with the parasitic inductances inherent in the

wiring of the circuit, can generate both noise spikes and offsets that are relatively large compared to the small voltages that are being measured across the current sensing resistor.

If the same power supply is used both for the gate drive circuit and for the current sensing circuit, it is very important that the connection from GND1 of the ACPL-C78A/C780/C784 to the sense resistor be the *only* return path for supply current to the gate drive power supply in order to eliminate potential ground loop problems. The only direct connection between the ACPL-C78A/C780/C784 circuit and the gate drive circuit should be the positive power supply line.

Output Side

The op-amp used in the external post-amplifier circuit should be of sufficiently high precision so that it does not contribute a significant amount of offset or offset drift relative to the contribution from the isolation amplifier. Generally, op-amps with bipolar input stages exhibit better offset performance than op-amps with JFET or MOSFET input stages.

In addition, the op-amp should also have enough bandwidth and slew rate so that it does not adversely affect the response speed of the overall circuit. The post-amplifier circuit includes a pair of capacitors (C5 and C6) that form a single-pole low-pass filter; these capacitors allow the bandwidth of the post-amp to be adjusted independently of the gain and are useful for reducing the output noise from the isolation amplifier. Many different op-amps could be used in the circuit, including: TL032A, TL052A, and TLC277 (Texas Instruments), LF412A (National Semiconductor).

The gain-setting resistors in the post-amp should have a tolerance of 1% or better to ensure adequate CMRR and adequate gain tolerance for the overall circuit. Resistor networks can be used that have much better ratio tolerances than can be achieved using discrete resistors. A resistor network also reduces the total number of components for the circuit as well as the required board space.

Frequently Asked Questions about the ACPL-C78A/C780/C784

1. The basics

- 1.1. Why should I use the ACPL-C78A/C780/C784 for sensing current when Hall-effect sensors are available which don't need an isolated supply voltage?

Available in an auto-insertable, Stretched SO-8 package, the ACPL-C78A/C780/C784 is smaller than and has better linearity, offset vs. temperature and Common Mode Rejection (CMR) performance than most Hall-effect sensors. Additionally, often the required input-side power supply can be derived from the same supply that powers the gate-drive optocoupler.

2. Sense resistor and input filter

- 2.1. Where do I get 10 mΩ resistors? I have never seen one that low.

Although less common than values above 10Ω, there are quite a few manufacturers of resistors suitable for measuring currents up to 50A when combined with the ACPL-C78A/C780/C784. Example product information may be found at Vishay's web site (<http://www.vishay.com>) and Isotek's web site (<http://www.isotekcorp.com>).

- 2.2. Should I connect both inputs across the sense resistor instead of grounding V_{IN-} directly to pin 4?

This is not necessary, but it will work. If you do, be sure to use an RC filter on both pin 2 (V_{IN+}) and pin 3 (V_{IN-}) to limit the input voltage at both pads.

- 2.3. Do I really need an RC filter on the input? What is it for? Are other values of R and C okay?

The input anti-aliasing filter ($R = 39\Omega$, $C = 0.01 \mu\text{F}$) shown in the typical application circuit is recommended for filtering fast switching voltage transients from the input signal. (This helps to attenuate higher signal frequencies which could otherwise alias with the input sampling rate and cause higher input offset voltage.)

Some issues to keep in mind using different filter resistors or capacitors are:

1. Filter resistor: Input bias current for pins 2 and 3: This is on the order of 500 nA. If you are using a single filter resistor in series with pin 2 but not pin 3 the $I \times R$ drop across this resistor will add to the offset error of the device. As long as this IR drop is small

compared to the input offset voltage there should not be a problem. If larger-valued resistors are used in series, it is better to put half of the resistance in series with pin 2 and half the resistance in series with pin 3. In this case, the offset voltage is due mainly to resistor mismatch (typically less than 1% of the resistance design value) multiplied by the input bias.

2. Filter resistor: The equivalent input resistance for ACPL-C78A/C780/C784 is around 500 kΩ. It is therefore best to ensure that the filter resistance is not a significant percentage of this value; otherwise the offset voltage will be increased through the resistor divider effect.

[As an example, if $R_{\text{filt}} = 5.5 \text{ k}\Omega$, then $V_{\text{OS}} = (V_{\text{in}} * 1\%) = 2 \text{ mV}$ for a maximum 200 mV input and V_{OS} will vary with respect to V_{in} .]

3. The input bandwidth is changed as a result of this different R-C filter configuration. In fact this is one of the main reasons for changing the input-filter R-C time constant.

4. Filter capacitance: The input capacitance of the ACPL-C78A/C780/C784 is approximately 1.5 pF. For proper operation the switching input-side sampling capacitors must be charged from a relatively fixed (low impedance) voltage source. Therefore, if a filter capacitor is used it is best for this capacitor to be a few orders of magnitude greater than the C_{INPUT} (a value of at least 100 pF works well).

- 2.4. How do I ensure that the ACPL-C78A/C780/C784 is not destroyed as a result of short circuit conditions which cause voltage drops across the sense resistor that exceed the ratings of the ACPL-C78A/C780/C784's inputs?

Select the sense resistor so that it will have less than 5V drop when short circuits occur. The only other requirement is to shut down the drive before the sense resistor is damaged or its solder joints melt. This ensures that the input of the ACPL-C78A/C780/C784 can not be damaged by sense resistors going open-circuit.

3. Isolation and insulation

- 3.1. How many volts will the ACPL-C78A/C780/C784 withstand?

The momentary (1 minute) withstand voltage is 5000 V rms per UL 1577 and CSA Component Acceptance Notice #5.

forward bias any junctions sufficiently to interfere with accurate operation of the switched capacitor input circuit.

4. Accuracy

4.1. Can the signal to noise ratio be improved?

Yes. Some noise energy exists beyond the 100 kHz bandwidth of the ACPL-C78A/C780/C784. Additional filtering using different filter R,C values in the post-amplifier application circuit can be used to improve the signal to noise ratio. For example, by using values of $R3 = R4 = 10 \text{ k}\Omega$, $C5 = C6 = 470 \text{ pF}$ in the application circuit the rms output noise will be cut roughly by a factor of 2. In applications needing only a few kHz bandwidth even better noise performance can be obtained. The noise spectral density is roughly $500 \text{ nV}/\sqrt{\text{Hz}}$ below 20 kHz (input referred).

4.2. Does the gain change if the internal LED light output degrades with time?

No. The LED is used only to transmit a digital pattern. Broadcom has accounted for LED degradation in the design of the product to ensure long life.

5. Power supplies and start-up

5.1. What are the output voltages before the input side power supply is turned on?

V_{OUT+} is close to 1.29V and V_{OUT-} is close to 3.80V. This is equivalent to the output response at the condition that LED is completely off.

5.2. How long does the ACPL-C78A/C780/C784 take to begin working properly after power-up?

Within 1 ms after V_{DD1} and V_{DD2} powered the device starts to work. But it takes longer time for output to settle down completely. In case of the offset measurement while both inputs are tied to ground there is initially V_{OS} adjustment (about 60 ms). The output completely settles down in 100 ms after device powering up.

6. Miscellaneous

6.1. How does the ACPL-C78A/C780/C784 measure negative signals with only a +5V supply?

The inputs have a series resistor for protection against large negative inputs. Normal signals are no more than 200 mV in amplitude. Such signals do not

Copyright © 2005-2023 Broadcom. All Rights Reserved. The term “Broadcom” refers to Broadcom Inc. and/or its subsidiaries. For more information, go to www.broadcom.com. All trademarks, trade names, service marks, and logos referenced herein belong to their respective companies.

Broadcom reserves the right to make changes without further notice to any products or data herein to improve reliability, function, or design. Information furnished by Broadcom is believed to be accurate and reliable. However, Broadcom does not assume any liability arising out of the application or use of this information, nor the application or use of any product or circuit described herein, neither does it convey any license under its patent rights nor the rights of others.

