

THIS DRAWING IS UNPUBLISHED. RELEASED FOR PUBLICATION
 © COPYRIGHT - By - ALL RIGHTS RESERVED.

| LOC | | DIST | | REVISIONS | | | |
|-----|----|-------------|---------------------------|-----------|------|----|--|
| P | TR | DESCRIPTION | DATE | DWN | APVD | | |
| GP | 00 | AA | REVISED PER ECO-14-011808 | 09AUG2014 | AP | SB | |

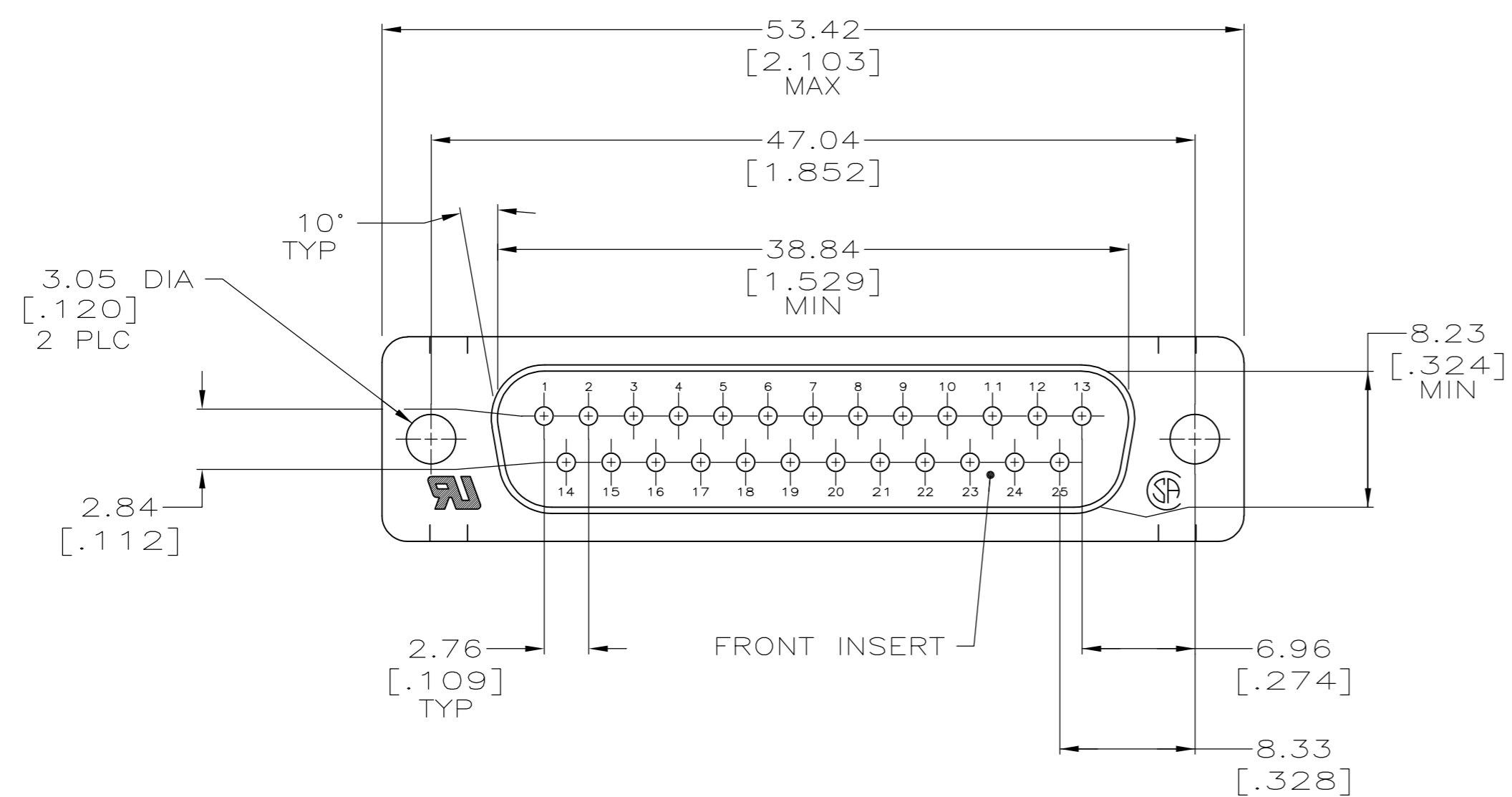

- ▲ MOLDED PARTS: GLASS-FILLED PBT OR GLASS-FILLED NYLON, UL94V-0 RATED. COLOR: BLACK
- SHELLS: CARBON STEEL.
- CONTACTS: BRASS.
- ▲ SHELLS: 5.08µm [.000200] MIN ZINC WITH YELLOW CHROMATE COATING.
- CONTACTS: GOLD PLATED FOR LENGTH OF 3.81 [.150] MIN FROM MATING END, MIN GOLD (SEE TABLE) IN MATED AREA. 2.54µm [.000100] MIN TIN-LEAD ON SOLDER END, ALL OVER 1.27µm [.000050] MIN NICKEL.
- 3. NOTE DELETED.
- 4. NOTE DELETED.
- 5. NOTE DELETED.
- ▲ NOTE DELETED.
- ▲ OBSOLETE PART NUMBER.
- ▲ SHELLS: 5.08µm [.000200] MIN ZINC WITH YELLOW CHROMATE COATING.
- CONTACTS: GOLD PLATED FOR LENGTH OF 3.81 [.150] MIN FROM MATING END, 0.76µm [.000030] MIN GOLD IN MATED AREA, 2.54µm [.000100] MIN TIN-LEAD ON SOLDER END, BOTH OVER 1.27µm [.000050] MIN NICKEL.
- OR
- GOLD FLASH OVER PALLADIUM-NICKEL PLATED FOR LENGTH OF 3.81 [.150] MIN FROM MATING END, 0.76µm [.000030] MIN TOTAL IN MATED AREA, 2.54µm [.000100] MIN TIN-LEAD ON SOLDER END, BOTH OVER 1.27µm [.000050] MIN NICKEL.

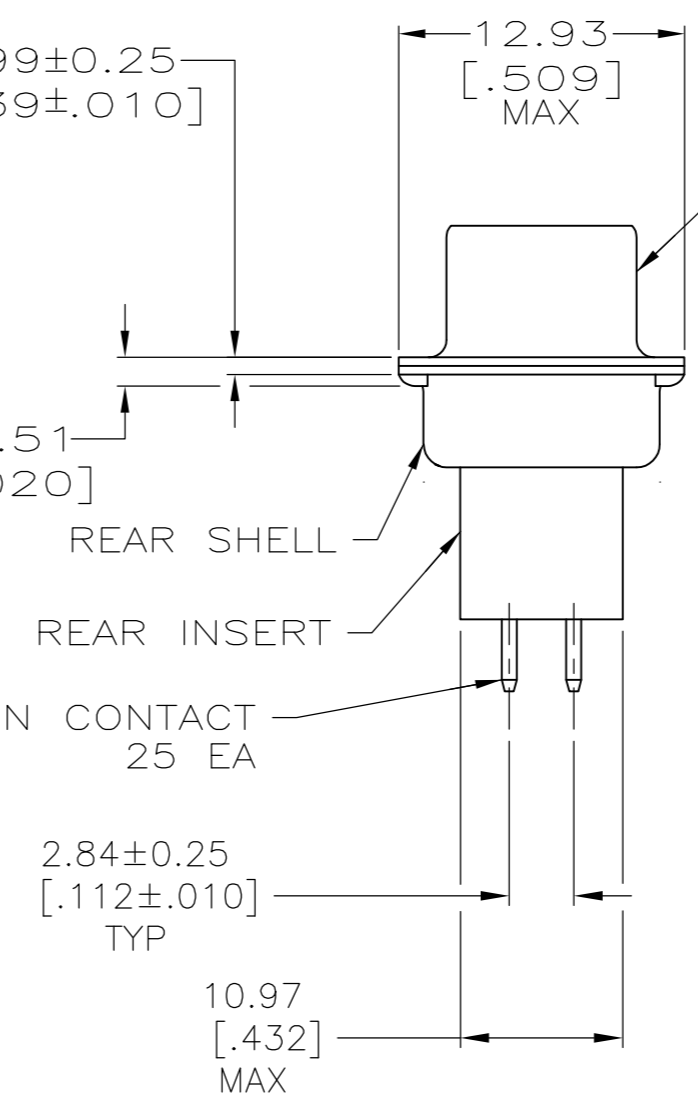
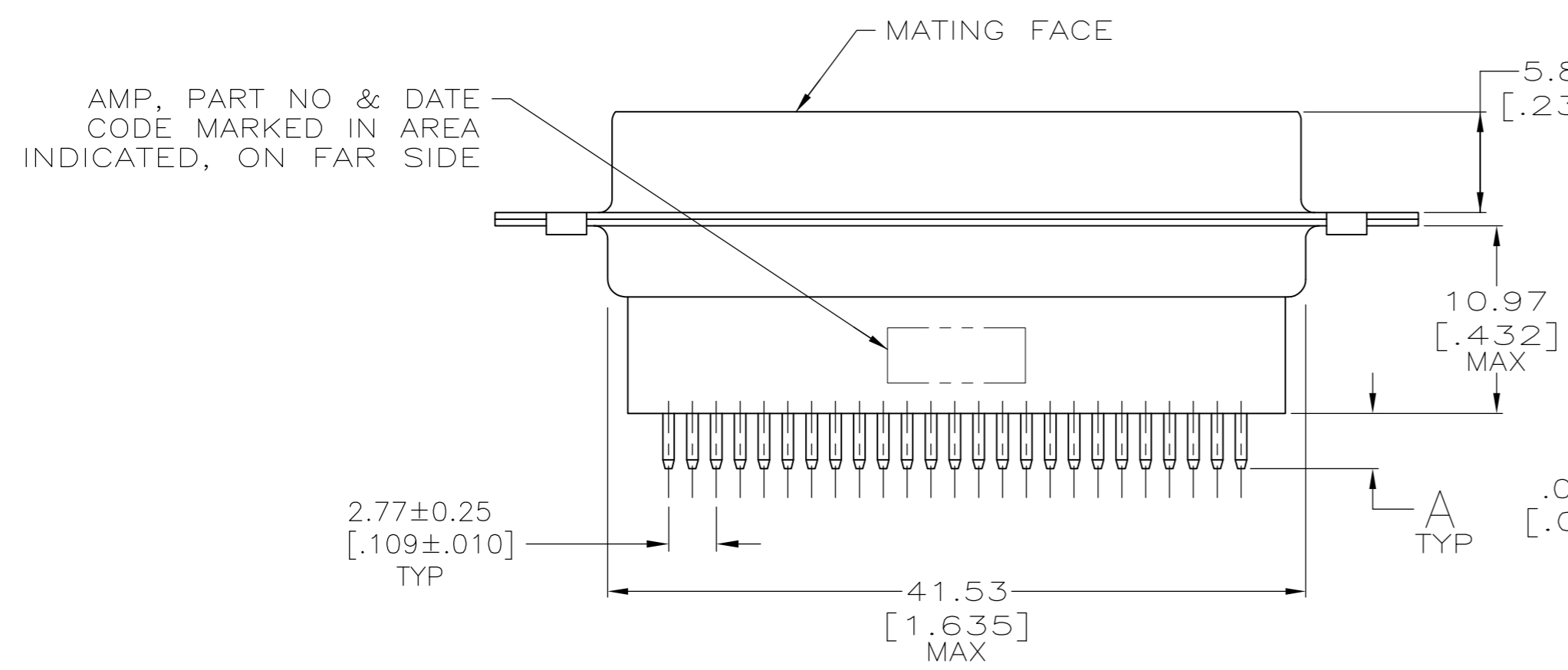

| | - | - | ▲ | 205737-9 |
|----------------|-------------|--------------|---|-------------|
| SUPSD 205737-7 | ▲ | 4.78 [.188] | | 205737-8 |
| | ▲ | 4.78 [.188] | | 205737-7 |
| SUPSD 205737-7 | ▲ | 16.54 [.651] | | 205737-6 |
| | - | - | ▲ | 205737-5 |
| SUPSD 205737-7 | ▲ | 10.85 [.427] | | 205737-4 |
| SUPSD 205737-7 | ▲ | 10.85 [.427] | | 205737-3 |
| SUPSD 205737-7 | ▲ | 3.18 [.125] | | 205737-2 |
| SUPSD 205737-7 | ▲ | 3.18 [.125] | | 205737-1 |
| | GOLD FINISH | A | | PART NUMBER |

THIS DRAWING IS A CONTROLLED DOCUMENT.

| | | |
|------|--------------|---------|
| DWN | J. POLIGNONE | 01FEB07 |
| CHK | E. BRIANT | 01FEB07 |
| APVD | E. BRIANT | 01FEB07 |

TE Connectivity

NAME: PLUG ASSY, SIZE 3, 25 POS, VERTICAL, -

| | |
|------------------|-----------|
| PRODUCT SPEC | 108-40025 |
| APPLICATION SPEC | 114-40013 |

| | | | | | | | |
|--------|----|-----------|-------|------------|----------|---------------|----|
| SIZE | A2 | CAGE CODE | 00779 | DRAWING NO | C=205737 | RESTRICTED TO | - |
| WEIGHT | - | SCALE | NTS | SHEET | 1 OF 1 | REV | AA |

CUSTOMER DRAWING