

P/N: MR04

Copyright

© 2016, FLIR Systems, Inc.

All rights reserved worldwide. Names and marks appearing herein are either registered trademarks or trademarks of FLIR Systems and/or its subsidiaries. All other trademarks, trade names or company names referenced herein are used for identification only and are the property of their respective owners.

Document identity

Publ. No.: MR04
 Release:
 Commit: 36663
 Language: en-US
 Modified: 2016-06-28
 Formatted: 2016-06-28

Website

<http://www.flir.com>

Customer support

<http://support.flir.com>

Disclaimer

Specifications subject to change without further notice. Camera models and accessories subject to regional market considerations. License procedures may apply. Products described herein may be subject to US Export Regulations. Please refer to exportquestions@flir.com with any questions.



General description	
Part number	MR04
Part name	Extension pole
When connected to a FLIR Moisture probe such as MR05 Impact Pin Probe or MR06 Wall Cavity Probe, the MR04 allows the user to measure moisture in wood and other building materials in difficult to reach areas from a safe distance.	
General information	
Warranty	2 years
Adjustment Angle	± 90°
Meter physical data	
Weight	466 g (1 lbs.)
Dimensions (H x W x L)	47.8 cm (18.83") collapsed; 134.3 cm (52.88") extended; 4 cm (1.6") x 5.5 cm (2.2")
Color	Black
Shipping Information	
Packaging, type	Retail box
Packaging, Contents	MR04 Extension Pole and Instruction sheet
Each Weight	0.70 kg
Each Dimensions (H x W x L)	7.2 x 52.1 x 6.7 cm
Master Carton Weight	8.4 Kg
Master Carton Dimensions (H x W x L)	35.1 x 55.9 x 26.7 cm
Master Carton Quantity	12
EAN-13	0793950370049
UPC-12	793950370049
Country of Origin	China
Tariff Code	9025.90.0000
Technical support	
Website	http://support.flir.com
E-mail	TMsupport@flir.com
Phone	855-499-3662
Repairs	repair@flir.com



MR04 Extension pole

P/N: MR04

© 2016, FLIR Systems, Inc.

#MR04; r. /36663; en-US

Accessories (optional)	
MR05	Moisture Probe
MR06	Wall Cavity Probe
MR07	Carry Case
MR08	Carry Case

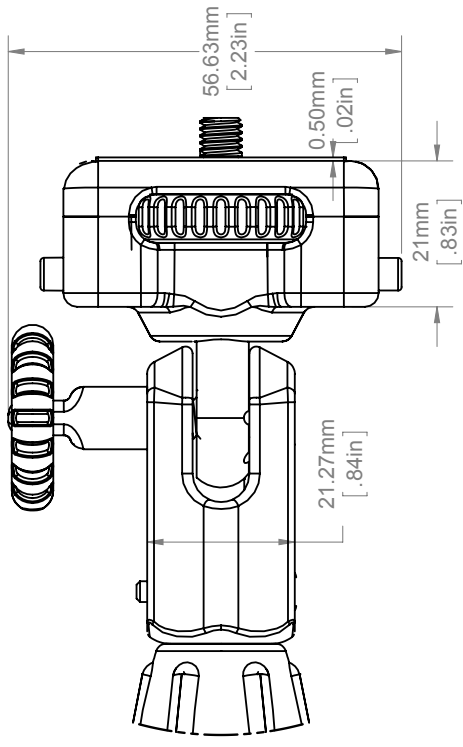

DETAIL A
SCALE 2 : 1.5

