

This drawing contains designs and other information which are the property of NEW ENGLAND INSTRUMENT COMPANY. Except for rights expressly granted by contract to the United States Government, this drawing may not, in whole or in part, be duplicated or its use or use for manufacture of the part described herein without the prior written permission of NEW ENGLAND INSTRUMENT COMPANY.

REVISIONS

REV	ECN NUMBER	DATE	APPROVED
A	ECN - #4656	3-17-82	CPB

1. SCOPE

1.1 Scope. This specification covers the detail requirements for a precision potentiometer, New England Instrument Co (hereinafter called NEI) type number **34FL1-160** equivalent to IDC Drawing 38908 Rev. A

2. APPLICABLE DOCUMENTS

2.1 The following documents, of the issue in effect on the date of issue of the applicable NEI sales order forms part of this specification to the extent specified herein:

SPECIFICATIONS

NEW ENGLAND INSTRUMENT COMPANY

1216-0000
1216-0160-70

3. REQUIREMENTS

3.1 General specifications. The potentiometers shall be as specified in NEI specification **1216-0000** except as modified or elaborated on herein. In the event of any conflict between this specification and the general specification, this specification shall govern.

Test Data. Test data form 1216-0160-70 shall be supplied with each unit.

UNLESS OTHERWISE SPECIFIED, DIMENSIONS ARE IN INCHES TOLERANCES: FRACTIONS ± .04 DECIMALS ± .001 ANGLES ± 2	DRAWN S. PROFIT 11-17-81	DATE 11-17-81	 NEW ENGLAND INSTRUMENT COMPANY NATICK, MASSACHUSETTS PRODUCT DEFINITION SPECIFICATION PRECISION POTENTIOMETER TYPE NO. 34FL1-160	
	CHECKED J. Baker 11/25/81	DATE 11/25/81		
MFG APPROVED DATE	APPROVED	DATE	DRAWING NUMBER 1216-0160-00	
Q.C. APPROVED DATE	APPROVED FOR NEI Ma 11/30/81	DATE 11/30/81		SIZE A
SALES APPROVED DATE	APPROVED FOR	DATE		CODE IDENT NO. 08815
SCALE:			SHEET 1 OF 7	

3.2 GENERAL CHARACTERISTICS

	CHARACTERISTICS	REQUIREMENT	QA CLASS		AQL
			Requirement Source		
1.	NO. OF CUPS	1	0	A	
2.	NO. OF SECTIONS	1	0	A	
3.	ELEMENT TYPE	"Resistofilm" Conductive Plastic	N/O	Q	
4.	BEARING TYPE	Ball	0	Q	
5.	MATERIAL MOUNTING PLATE	Anodized Aluminum	N/O	Q	
6.	MATERIAL HOUSING	Anodized Aluminum	0	Q	
7.	MATERIAL SHAFT	Stainless Steel	0	Q	
8.	WEIGHT	3 oz. max.	0	Q	

3.3 MECHANICAL PARAMETERS

	PARAMETER	REQUIREMENT	QA CLASS		AQL
			Requirement Source		
1.	LATERAL RUNOUT	0.001 TIR max.	N/O	A	
2.	PILOT SURFACE RUNOUT	0.001 TIR max.	0	A	
3.	SHAFT RUNOUT	0.001 TIR max.	0	A	
4.	END PLAY	0.005 TIR max.	0	A	
5.	RADIAL PLAY	0.001 TIR max.	0	A	
6.	STARTING TORQUE	0.30 oz.-in. max.	0	A	
7.	RUNNING TORQUE	0.24 oz.-in. max.	0	A	
8.	MOMENT OF INERTIA	N/R	-	-	
9.	STATIC STOP STRENGTH	N/A	-	-	
10.	DYNAMIC STOP STRENGTH	N/A	-	-	
11.	MECHANICAL TRAVEL	360° Continuous	N/O	A	

LEGEND

Requirement Source -- N - NEI; O - OEM
 QA Class -- A - Acceptance Test,
 P - Preproduction Test; Q - Qualification Test

SIZE

A

CODE IDENT NO.

08815

DRAWING NUMBER

1216-0160-00

SCALE:

REV

A

SHEET 2

3.4 ELECTRICAL AND ELECTROMECHANICAL PARAMETERS

AQL

PARAMETER	REQUIREMENT	QA CLASS	
		Requirement Source	
1. DIELECTRIC WITH STANDING VOLTAGE	750 VRMS	0	A
2. INSULATION RESISTANCE	1000 Megohm min.	0	A
3. RESISTANCE TEMPERATURE CHARACTERISTIC	N/R	-	-
4. POWER RATING	0.5 watts derated to 0.45 watts @ 50°C	0	Q
5. EXCITATION FREQ FOR AC CHARACTERISTICS	N/R	-	-
6. QUADRATURE VOLTAGE	N/A	-	-
7. PHASE SHIFT	N/A	-	-
8. CONFORMITY OF IN-PHASE COMPONENT	N/A	-	-
9. TOTAL INPUT IMPEDANCE	N/A	-	-
10. OUTPUT SMOOTHNESS	0.1% max.	0	A
11. Theoretical ELECTRICAL TRAVEL	350°	0	A
12. ELECTRICAL OVERTRAVEL	0° min.	0	A
13. MECHANICAL OVERTRAVEL	N/A	-	-
14. CONTINUITY TRAVEL	358° max.	N/O	A
15. INDEX POINT	@ θ=14.4°, Output ratio limits: 0.00986/0.01386	N	A
16. CONFORMITY DEFINITION	Absolute Conformity	0	A
17. PHASING	N/A	-	-
18. TAP LOCATION	N/R	-	-
19. EFFECTIVE TAP WIDTH	N/A	-	-
20. BACKLASH	N/R	-	-
21. RESOLUTION	Virtually Infinite	N/O	A
22. MINIMUM VOLTAGE	N/R	-	-
23. END VOLTAGE	N/A	-	-

SIZE

CODE IDENT NO

DRAWING NUMBER

A

08815

1216-0160-00

SCALE

REV

A

SHEET

3

3.5 REQUIREMENTS OF INDIVIDUAL SECTIONS

3.5.1 Total Resistance

9000 - 11000 ohms

3.5.2 Function Characteristic

The output ratio (e/E) when measured in accordance with the schematic diagram shall conform to Table I.

θ increases with CCW shaft travel.

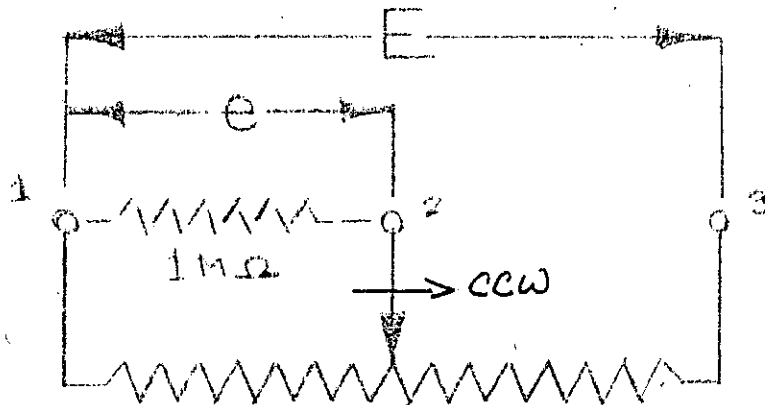

SIZE	CODE IDENT NO.	DRAWING NUMBER
A	08815	1216-0160-00
SCALE	REV	SHEET 4
	A	

SHAFT POSITION	O U T NOMINAL	P U T MINIMUM	R A T I O MEASURED	T I O MAXIMUM
.0	.00000	.00000		.00200
14.4	.01186	.00986		.01386
28.8	.02372	.02172		.02572
43.2	.03558	.03358		.03758
50.4	.05300	.05100		.05500
57.6	.07029	.06829		.07229
64.8	.08997	.08797		.09197
72.0	.10964	.10764		.11164
79.2	.13279	.13079		.13479
86.4	.15593	.15393		.15793
93.6	.17910	.17710		.18110
100.8	.20222	.20022		.20422
108.0	.22537	.22337		.22737
115.2	.24851	.24651		.25051
122.4	.27155	.26955		.27355
129.6	.29459	.29259		.29659
136.8	.31765	.31565		.31965
144.0	.34069	.33869		.34269
151.2	.36375	.36175		.36575
158.4	.38678	.38478		.38878
165.6	.40984	.40784		.41184
172.8	.43288	.43088		.43488
180.0	.45592	.45392		.45792
187.2	.47898	.47698		.48098
194.4	.50202	.50002		.50402
201.6	.52508	.52308		.52708
208.8	.54812	.54612		.55012
216.0	.57115	.56915		.57315
223.2	.59421	.59221		.59621
230.4	.61725	.61525		.61925
237.6	.64031	.63831		.64231
244.8	.66335	.66135		.66535
252.0	.68639	.68439		.68839
259.2	.70945	.70745		.71145
350.0	1.00000	.99800		1.00000

TABLE I

SIZE	CODE IDENT NO.	DRAWING NUMBER
A	08815	1216-0160-00
SCALE	REV	SHEET
	A	5

DRAFTING 250

3.6 Marking. The potentiometer shall be permanently and legibly marked as follows:

3.6.1 The size and color of the marking shall be as follows:

- a) Size (height) - $3/64$ min., $9/64$ max.
- b) Color - white

3.6.2 The markings on the cylindrical surface shall consist of the following:

- a) NEI logotype and MFR 08815
- b) NEI type number: 34FL1-160
- c) Electronic Industries Association date code
- d) Serial Number
- e) Terminal identification (See Figure 1)
- f) O.E.M. part number as follows: 38908 REV *

* REVISION OF CUSTOMER DRAWING PER PART 11

	SIZE	CODE IDENT NO.	DRAWING NUMBER
	A	08815	1216-0160-00
	SCALE	REV A	SHEET 6

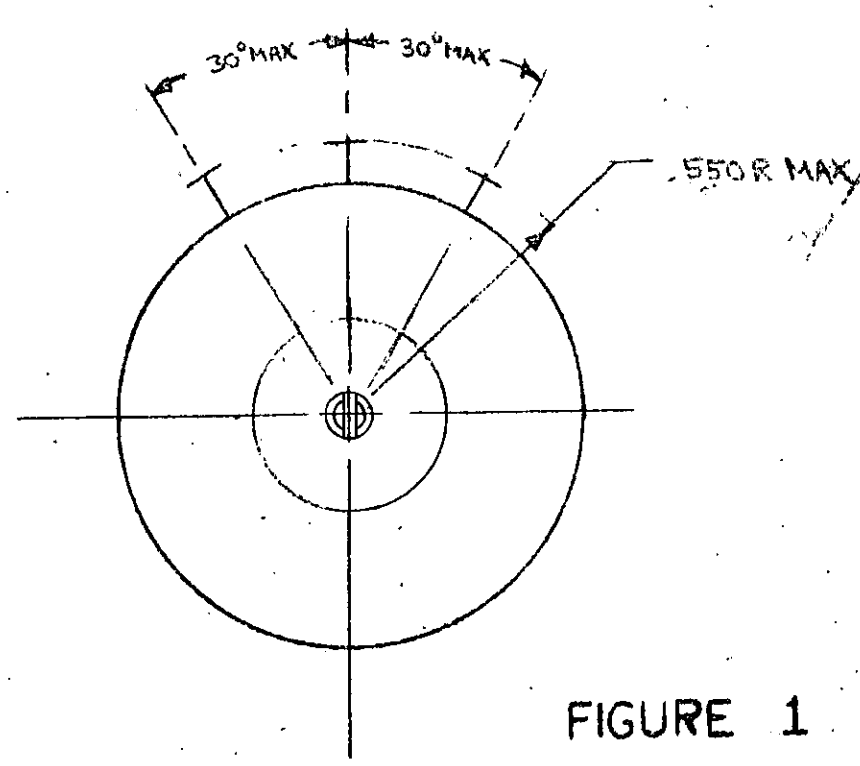
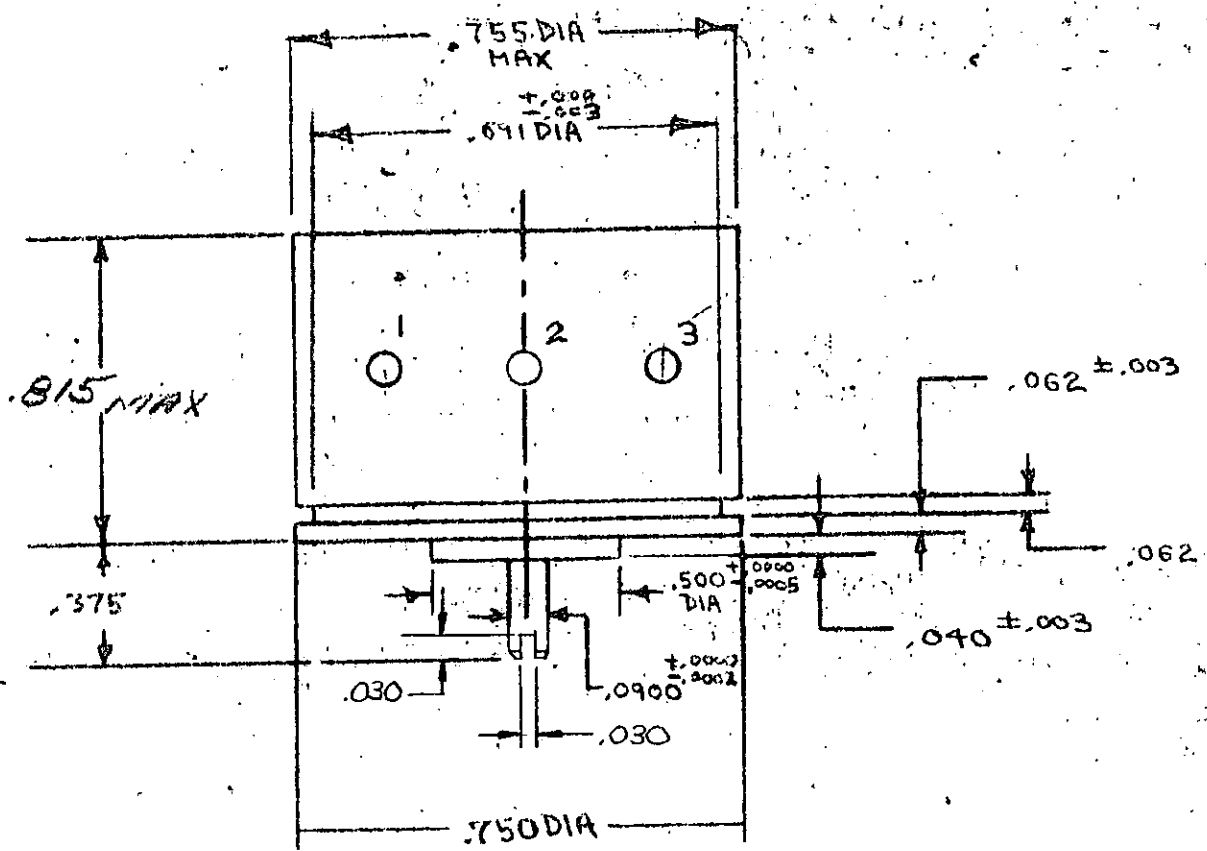

FIGURE 1

SIZE	CODE IDENT NO.	DRAWING NUMBER
A	08815	1216-0160--00
SCALE: \times	REV. A	SHEET 7