

5 Nm RC65 3.9 Watts 3.9 W Part number made to order



- Torque rating of gearboxes : 5 Nm, metal gears
- Motors : nominal power 3 W / interference suppression for standard stocked products
- Speed range : 1.7 to 344 rpm
- Optional encoder built into the motor

Part numbers

	Type	Type	Voltage	Output speed (rpm)	Ratios (i)
MADE TO ORDER	3.9 W	828670	24 V	1,72	2500

Specifications

General characteristics

Motor	828600
Gearbox	810370
Maximum permitted torque from gearmotor under continuous conditions for 1 million turns (Nm)	5
Axial load dynamic (daN)	2
Radial load dynamic (daN)	3
Max. output power (W)	3,9
Nominal output (W)	3
Gearbox case temperature rise (°C)	50
Weight (g)	465

Dimensions (mm)

828670

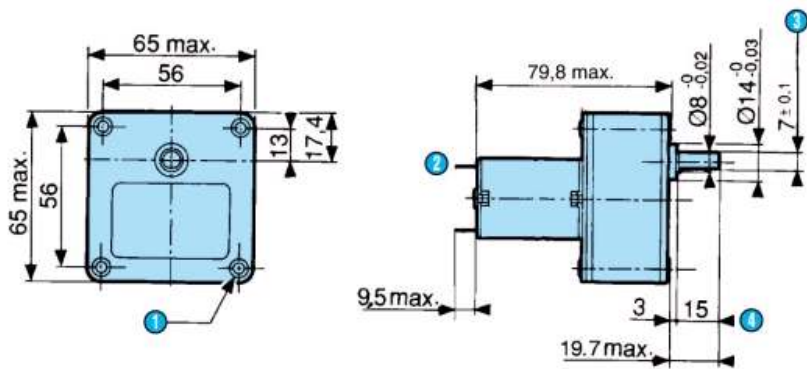

N°	Legend
①	4 fixing holes Ø M4 x 12
②	2 standard tags NFC 20-120, series 2.8 x 0.5 mm
③	7 ± 0.1 across flats
④	Shaft pushed-in

Dimensions (mm)

Shaft 79206478

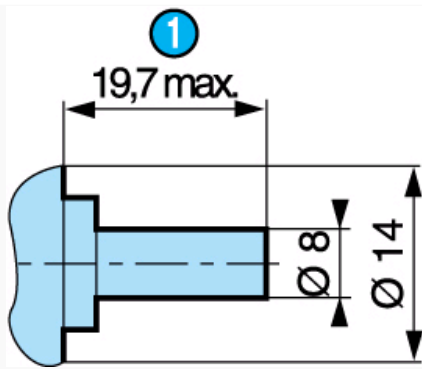

N°	Legend
1	Shaft pushed-in

Curves

Curve : torque/nominal speed

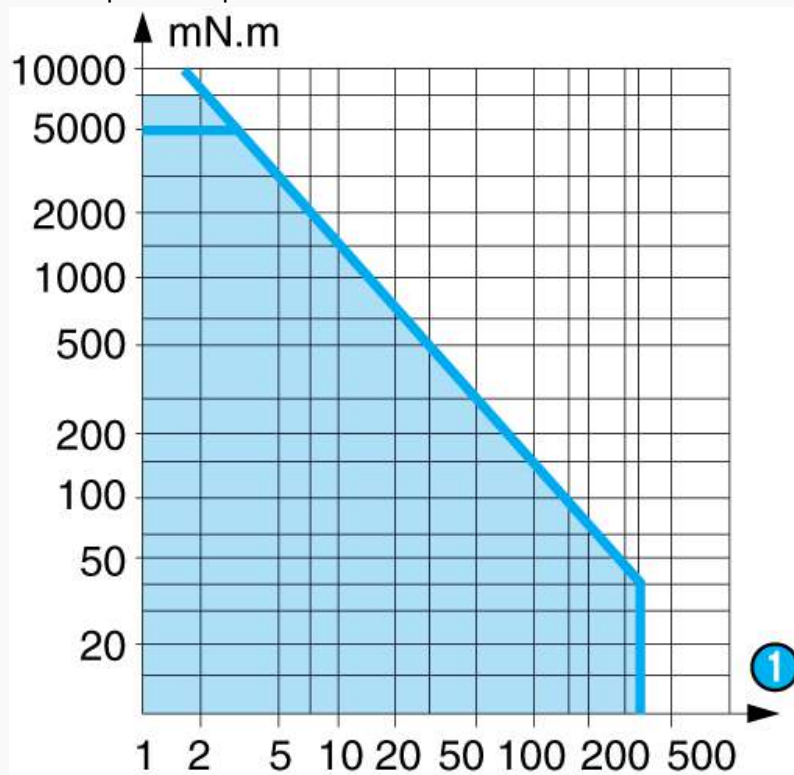

N°	Legend
1	rpm

Product adaptations



- Special supply voltage
- Lead output
- 1 or 5 pulse Hall effect encoder
- Special connectors
- Special shaft
- Special reduction ratio (40 ratios available from 4 to 3750)
- Special materials for gears
- Special ball bearings
- Special adaptor plate
- EMC filter
- With shorter 1 W motor