

DO NOT SCALE FROM THIS PRINT

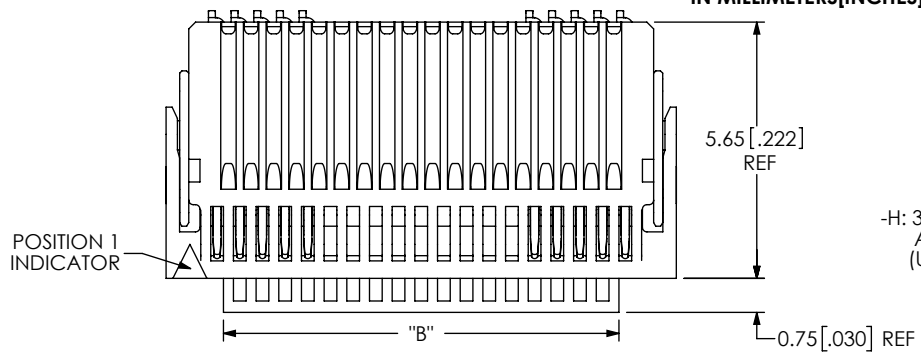

No OF POSITIONS
-019, *-025, *-038, *-050 (PER ROW)

LEAD STYLE
-1:

PLATING SPECIFICATION
-H: 30µ" GOLD IN CONTACT AREA, GOLD FLASH ON TAIL (USE C-409-01-H, C-410-01-H)

ROW SPECIFICATION
-D: DOUBLE ROW

OPTION
-A: ALIGNMENT PIN

WELD TAB STYLE
-1: THRU HOLE
-2: SURFACE MOUNT

RIGHT ANGLE
-RA: RIGHT ANGLE

(* = NOT TOOLED)

MULTIPLE PATENTS PENDING

THIS IS THE SECOND GENERATION DESIGN OF THE UEC5 (RUGGEDIZED). SEE DRAWING No ASP-180864-01 FOR THE ORIGINAL DESIGN (ONLY AVAILABLE TO EXISTING CUSTOMERS)

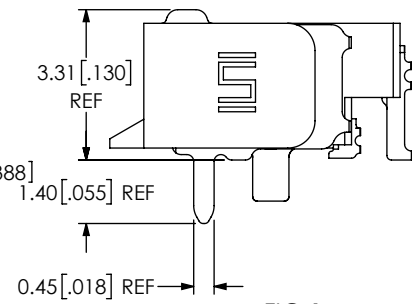

FIG 1
UEC5-019-1-X-D-RA-1-A SHOWN (SOME CENTER FEATURES REMOVED FOR CLARITY) (PP NOT SHOWN FOR CLARITY)

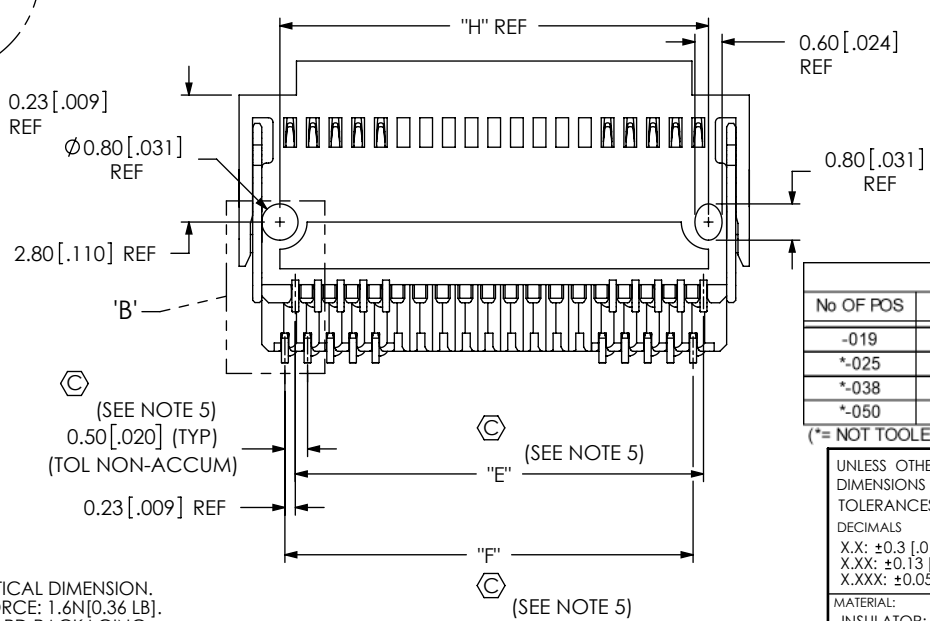
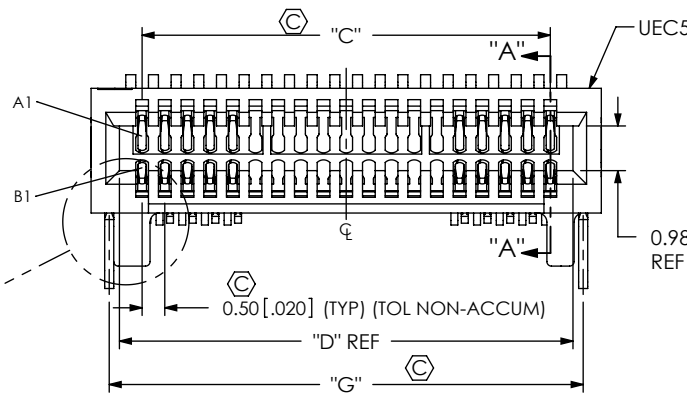
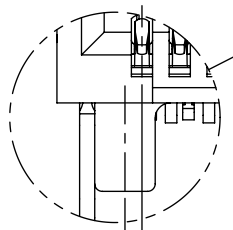
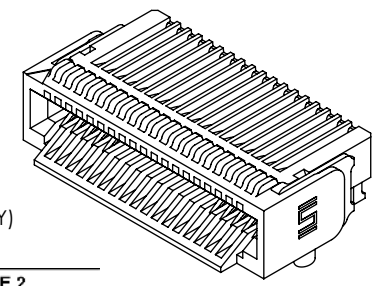

TABLE 2

No. OF POS	"A"
-019	11.25 [0.443]
*-025	14.25 [0.561]
*-038	22.00 [0.866]
*-050	28.00 [1.102]

(* = NOT TOOLED)

TABLE 1

No OF POS	"B"	"C"	"D"	"E"	"F"	"G"	"H"
-019	8.72 [0.343]	9.00 [0.354]	10.00 [0.394]	9.00 [0.354]	9.00 [0.354]	10.45 [0.411]	9.45 [0.372]
*-025	11.72 [0.461]	12.00 [0.472]	13.00 [0.512]	12.00 [0.472]	12.00 [0.472]	13.45 [0.530]	12.45 [0.490]
*-038	8.72 [0.343]	19.75 [0.778]	N/A	19.75 [0.778]	19.75 [0.778]	21.20 [0.835]	20.20 [0.795]
*-050	11.72 [0.461]	25.75 [1.014]	N/A	25.75 [1.014]	25.75 [1.014]	27.20 [1.071]	26.20 [1.031]

(* = NOT TOOLED)

- NOTES:
- ⊗ REPRESENTS A CRITICAL DIMENSION.
 - MINIMUM PUSHOUT FORCE: 1.6N [0.36 LB].
 - TAPE & REEL IS STANDARD PACKAGING
 - FOR QUANTITIES UP TO 49 PIECES, NO LEADER, TRAILER OR EIA-481 REEL WILL BE SUPPLIED.
 - FOR QUANTITIES 50-124, NO LEADER OR TRAILER WILL BE SUPPLIED.
 - USE INSPECTION FIXTURE, SAMTEC P/N AT-2450-800, WHEN INSPECTING SOLDER TAIL CRITICAL DIMENSIONS.
 - K-DOT PROVIDED AS STANDARD.

UNLESS OTHERWISE SPECIFIED, DIMENSIONS ARE IN MILLIMETERS. TOLERANCES ARE:
DECIMALS ANGLES
X.X: ±0.3 [0.1] 2°
X.XX: ±0.13 [0.05]
X.XXX: ±0.051 [0.020]

PROPRIETARY NOTE
THIS DOCUMENT CONTAINS CONFIDENTIAL AND PROPRIETARY INFORMATION AND ALL DESIGN, MANUFACTURING, REPRODUCTION, USE, PATENT RIGHTS AND SALES RIGHTS ARE EXPRESSLY RESERVED BY SAMTEC, INC. THIS DOCUMENT SHALL NOT BE DISCLOSED, IN WHOLE OR PART, TO ANY UNAUTHORIZED PERSON OR ENTITY NOR REPRODUCED, TRANSFERRED OR INCORPORATED IN ANY OTHER PROJECT IN ANY MANNER WITHOUT THE EXPRESS WRITTEN CONSENT OF SAMTEC, INC.

MATERIAL: DO NOT SCALE DRAWING SHEET SCALE: 6:1
INSULATOR: LCP, COLOR: BLACK
CONTACT: BeCu

520 PARK EAST BLVD, NEW ALBANY, IN 47150
PHONE: 812-944-6733 FAX: 812-948-5047
e-Mail: info@SAMTEC.com code 53322

DESCRIPTION:
0.5MM EDGE RATE SOCKET ASSEMBLY

DWG. NO.
UEC5-XXX-1-X-D-RA-X-A

BY: KNOWLDEN 9/10/2013 SHEET 1 OF 5

REVISION G

TABLE 3			
No OF POS	BOTTOM ROW STRAIGHTNESS	TOP ROW STRAIGHTNESS	COPLANARITY
-019, *-025	0.10 [0.004]	0.10 [0.004]	0.10 [0.004]
*-038, *-050	0.10 [0.004]	0.10 [0.004]	0.13 [0.005]

(* = NOT TOOLED)

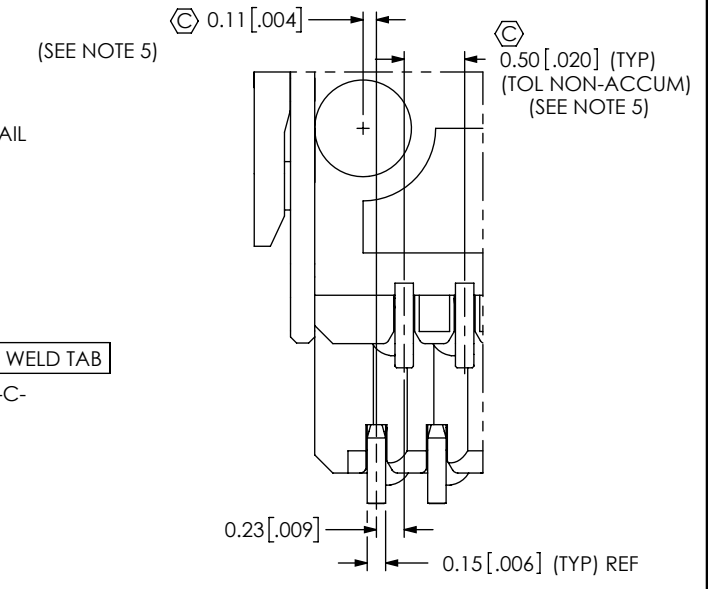
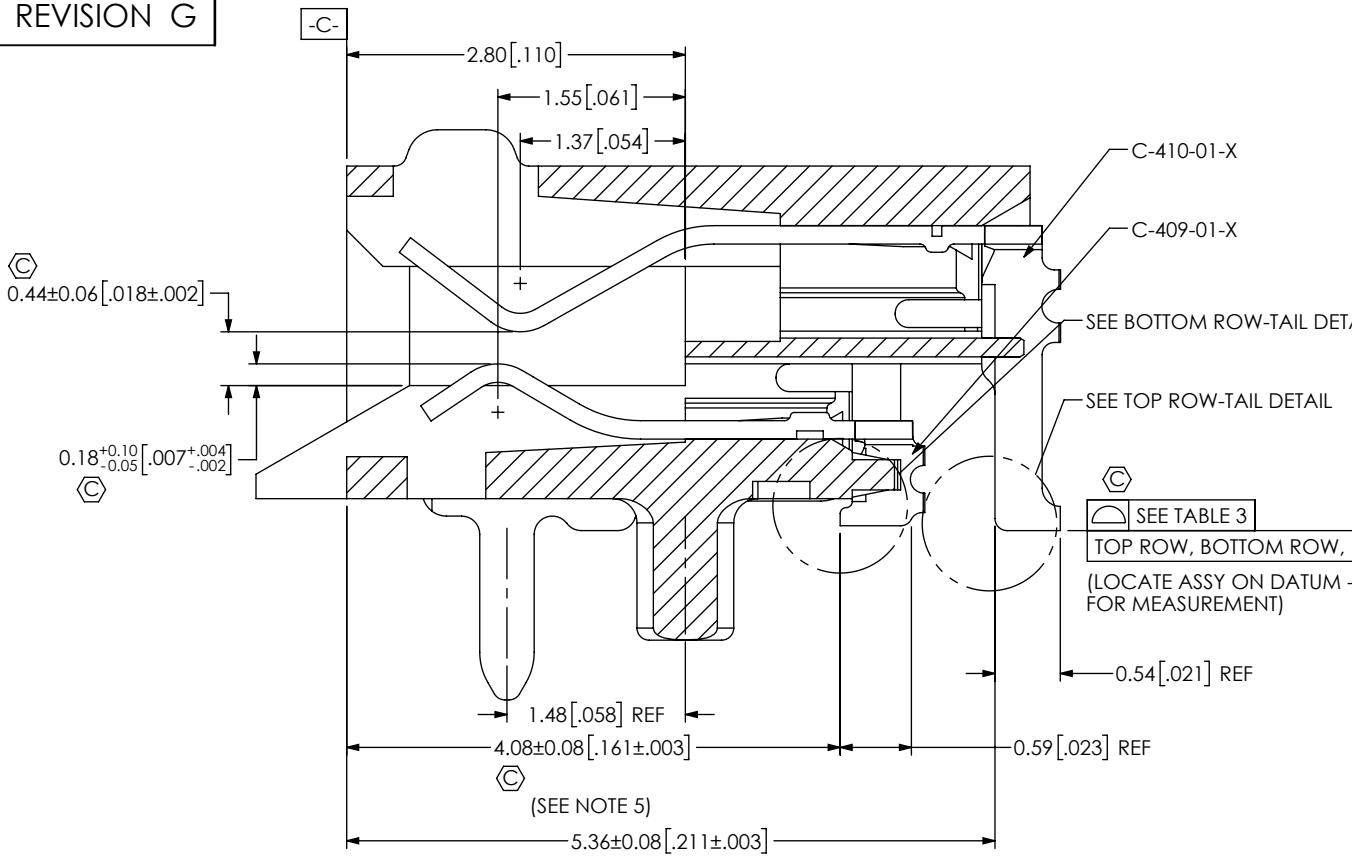

SCALE 16 : 1

(SEE NOTE 5)
SECTION "A"-"A"
SCALE 16 : 1

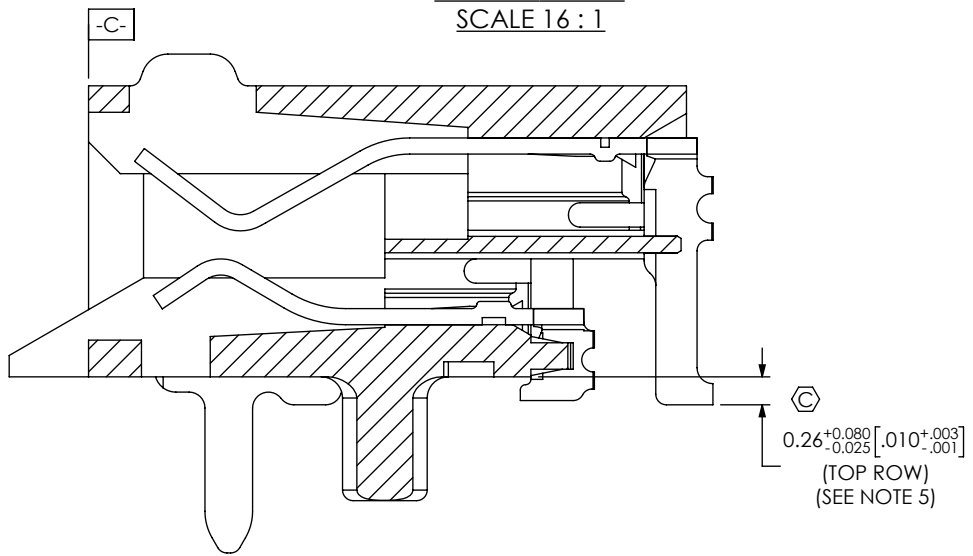

TOP ROW-TAIL DETAIL
(LOCATE ASSY ON DATUM -C- FOR MEASUREMENT)

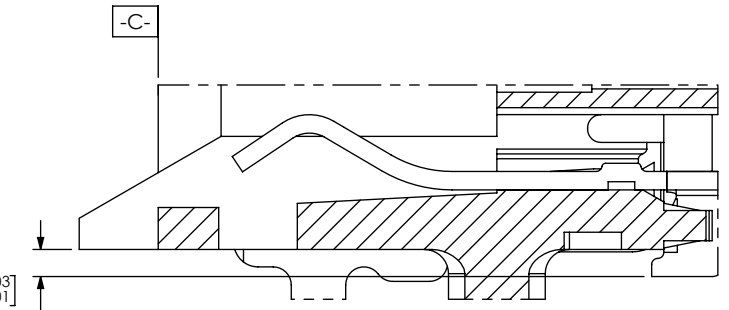

BOTTOM ROW-TAIL DETAIL
(LOCATE ASSY ON DATUM -C- FOR MEASUREMENT)

<p>PROPRIETARY NOTE</p> <p>THIS DOCUMENT CONTAINS CONFIDENTIAL AND PROPRIETARY INFORMATION AND ALL DESIGN, MANUFACTURING, REPRODUCTION, USE, PATENT RIGHTS AND SALES RIGHTS ARE EXPRESSLY RESERVED BY SAMTEC, INC. THIS DOCUMENT SHALL NOT BE DISCLOSED, IN WHOLE OR PART, TO ANY UNAUTHORIZED PERSON OR ENTITY NOR REPRODUCED, TRANSFERRED OR INCORPORATED IN ANY OTHER PROJECT IN ANY MANNER WITHOUT THE EXPRESS WRITTEN CONSENT OF SAMTEC, INC.</p> <p>DO NOT SCALE DRAWING</p> <p>SHEET SCALE: 16:1</p>		
	<p>520 PARK EAST BLVD. NEW ALBANY, IN 47150 PHONE: 812-944-6733 FAX: 812-948-5047 e-Mail: info@SAMTEC.com code 55322</p>	
	<p>DESCRIPTION: 0.5MM EDGE RATE SOCKET ASSEMBLY</p>	
	<p>DWG. NO. UEC5-XXX-1-X-D-RA-X-A</p>	
<p>BY: KNOWLDEN 9/10/2013</p>		<p>SHEET 2 OF 5</p>

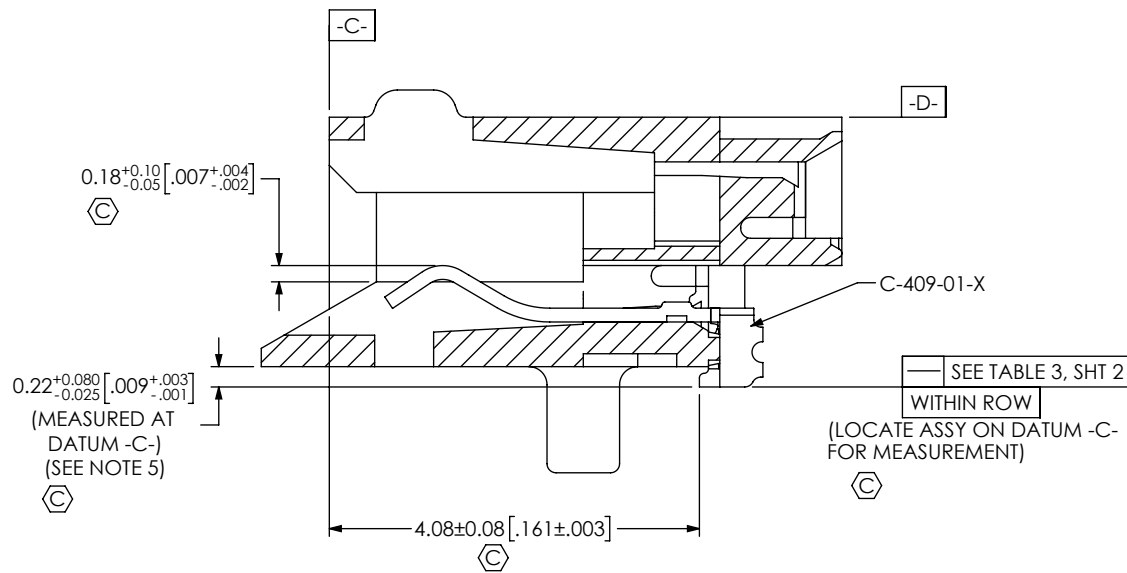

(SEE NOTE 5)
(LOCATE ASSY ON DATUM -D- FOR MEASUREMENT)

IN-PROCESS 1
FILL C-409-01-X

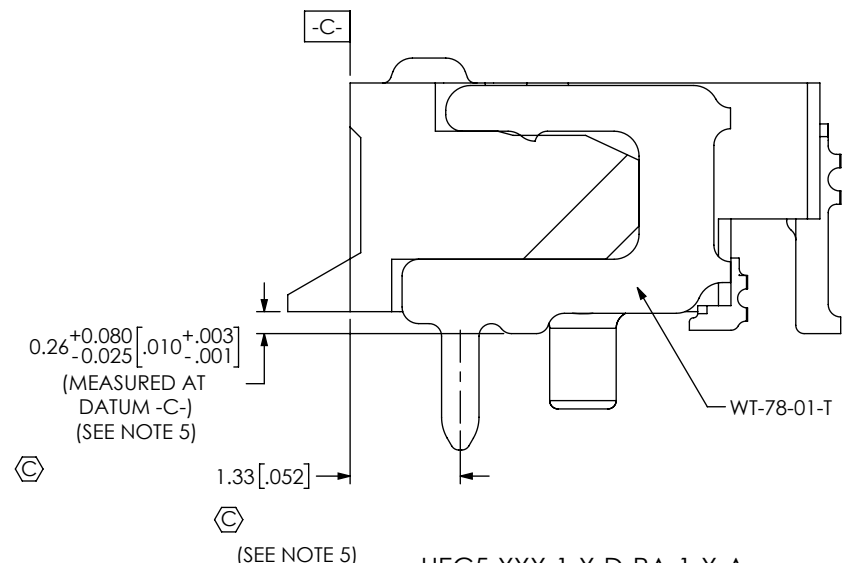

UEC5-XXX-1-X-D-RA-1-X-A
IN-PROCESS 3
(FILL WT-78-01-X, THRU HOLE WELD TAB)

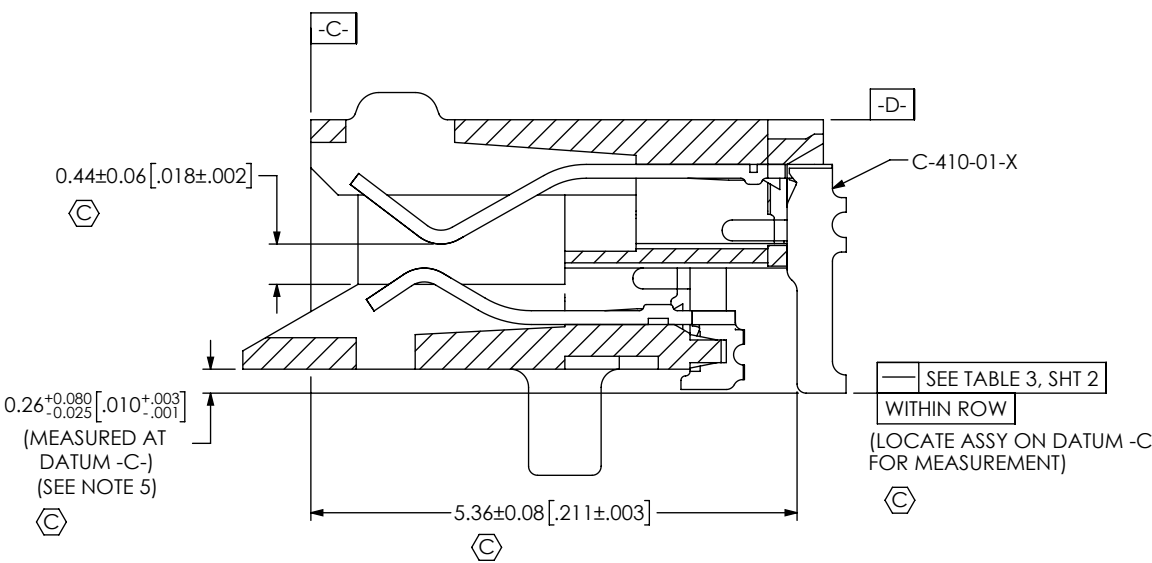

(SEE NOTE 5)
(LOCATE ASSY ON DATUM -D- FOR MEASUREMENT)

IN-PROCESS 2
FILL C-410-01-X

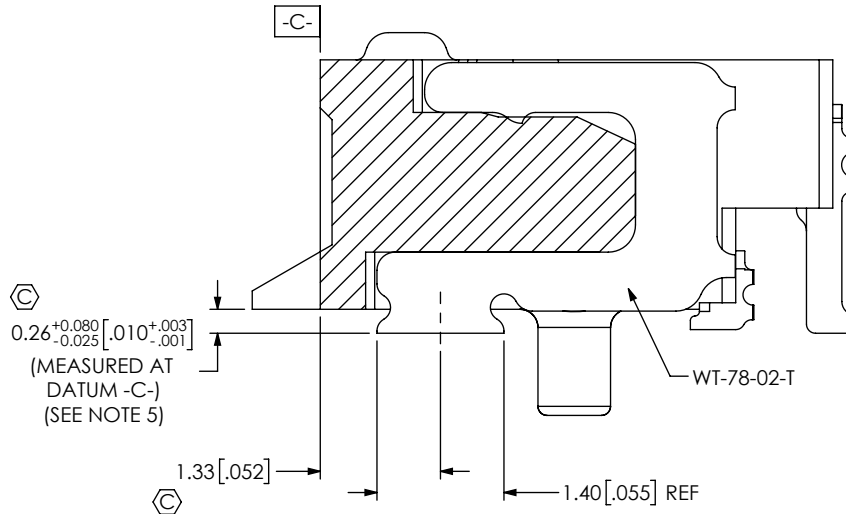

UEC5-XXX-1-X-D-RA-2-X-A
ALTERNATE IN-PROCESS 3
(FILL WT-78-02-X, SURFACE MOUNT WELD TAB)

PROPRIETARY NOTE
THIS DOCUMENT CONTAINS CONFIDENTIAL AND PROPRIETARY INFORMATION AND ALL DESIGN, MANUFACTURING, REPRODUCTION, USE, PATENT RIGHTS AND SALES RIGHTS ARE EXPRESSLY RESERVED BY SAMTEC, INC. THIS DOCUMENT SHALL NOT BE DISCLOSED, IN WHOLE OR PART, TO ANY UNAUTHORIZED PERSON OR ENTITY NOR REPRODUCED, TRANSFERRED OR INCORPORATED IN ANY OTHER PROJECT IN ANY MANNER WITHOUT THE EXPRESS WRITTEN CONSENT OF SAMTEC, INC.

DO NOT SCALE DRAWING
SHEET SCALE: 12:1



520 PARK EAST BLVD, NEW ALBANY, IN 47150
PHONE: 812-944-6733 FAX: 812-948-5047
e-Mail: info@SAMTEC.com code 55322

DESCRIPTION:
0.5MM EDGE RATE SOCKET ASSEMBLY

DWG. NO.
UEC5-XXX-1-X-D-RA-X-A

BY: KNOWLDEN 9/10/2013 SHEET 3 OF 5

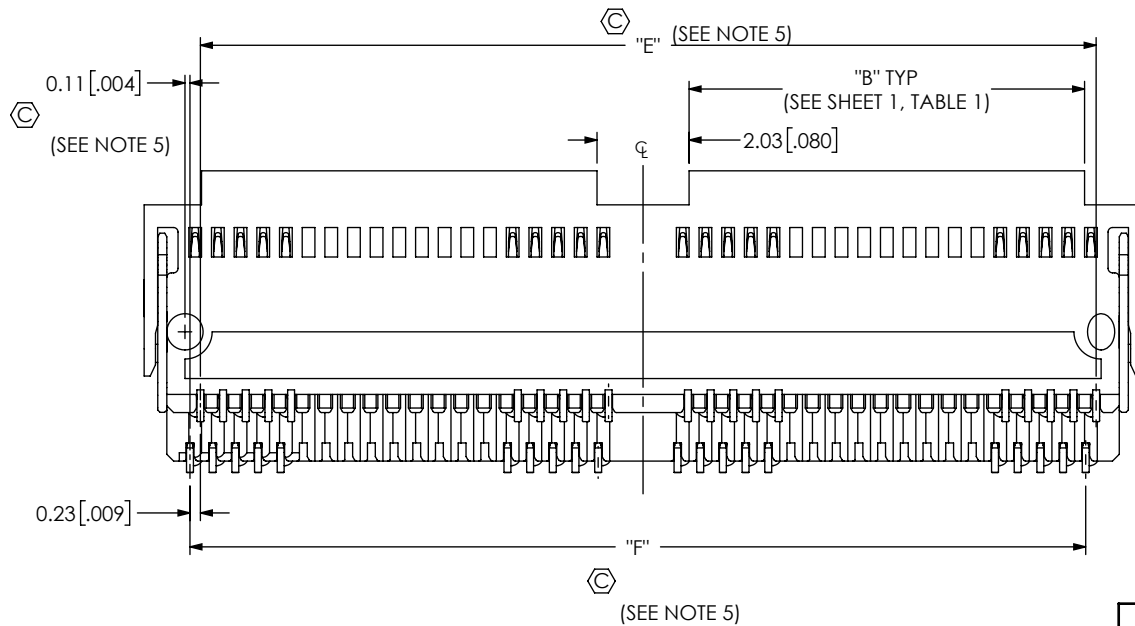
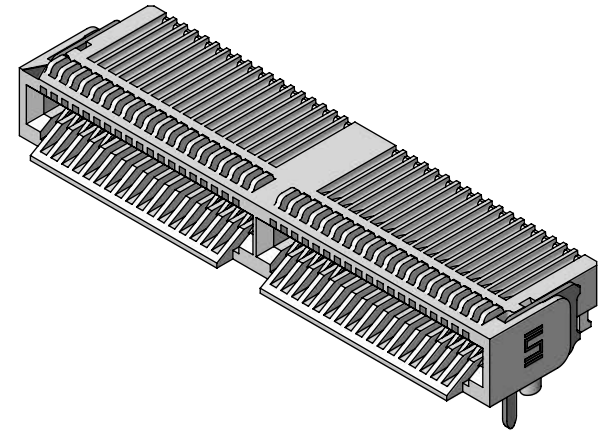
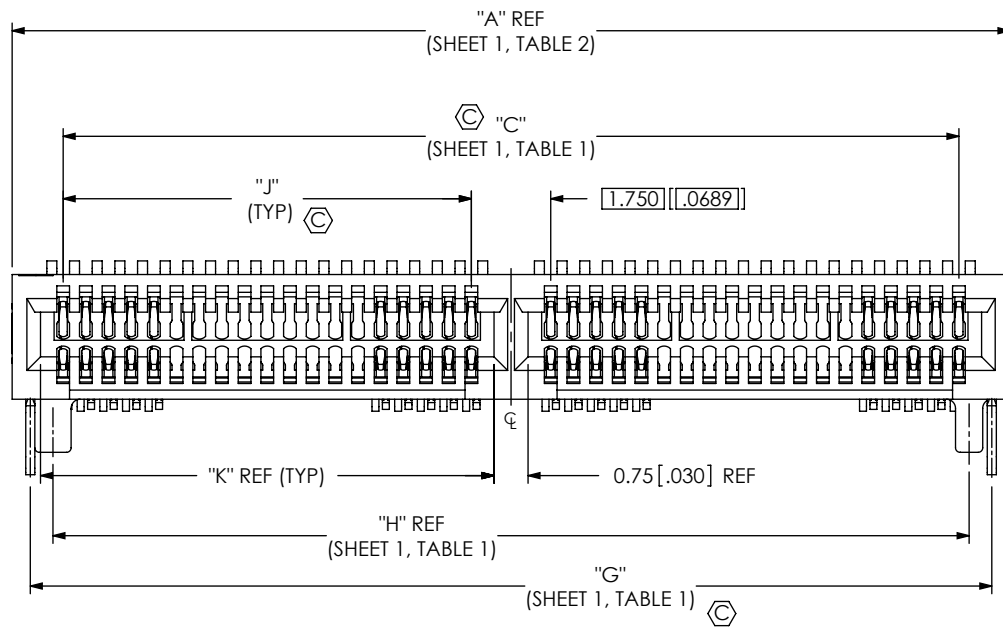

No OF POS	"J"	"K"
-019	N/A	N/A
*-025	N/A	N/A
*-038	9.00 [0.354]	10.00 [0.394]
*-050	12.00 [0.472]	13.00 [0.512]

(* = NOT TOOLED)

FIG 2
 UEC5-038-1-X-D-RA-1-A SHOWN
 (DIFFERENT AS SHOWN, OTHERWISE SAME AS FIG 1)
 (SOME CENTER FEATURES REMOVED FOR CLARITY)
 (PP NOT SHOWN FOR CLARITY)
 (NOT TOOLED)

PROPRIETARY NOTE
 THIS DOCUMENT CONTAINS CONFIDENTIAL AND PROPRIETARY INFORMATION AND ALL DESIGN, MANUFACTURING, REPRODUCTION, USE, PATENT RIGHTS AND SALES RIGHTS ARE EXPRESSLY RESERVED BY SAMTEC, INC. THIS DOCUMENT SHALL NOT BE DISCLOSED, IN WHOLE OR PART, TO ANY UNAUTHORIZED PERSON OR ENTITY NOR REPRODUCED, TRANSFERRED OR INCORPORATED IN ANY OTHER PROJECT IN ANY MANNER WITHOUT THE EXPRESS WRITTEN CONSENT OF SAMTEC, INC.

DO NOT SCALE DRAWING

SHEET SCALE: 6:1



520 PARK EAST BLVD, NEW ALBANY, IN 47150
 PHONE: 812-944-6733 FAX: 812-948-5047
 e-Mail info@SAMTEC.com code 55322

DESCRIPTION:
 0.5MM EDGE RATE SOCKET ASSEMBLY

DWG. NO.
 UEC5-XXX-1-X-D-RA-X-A

BY: KNOWLDEN 9/10/2013 SHEET 4 OF 5

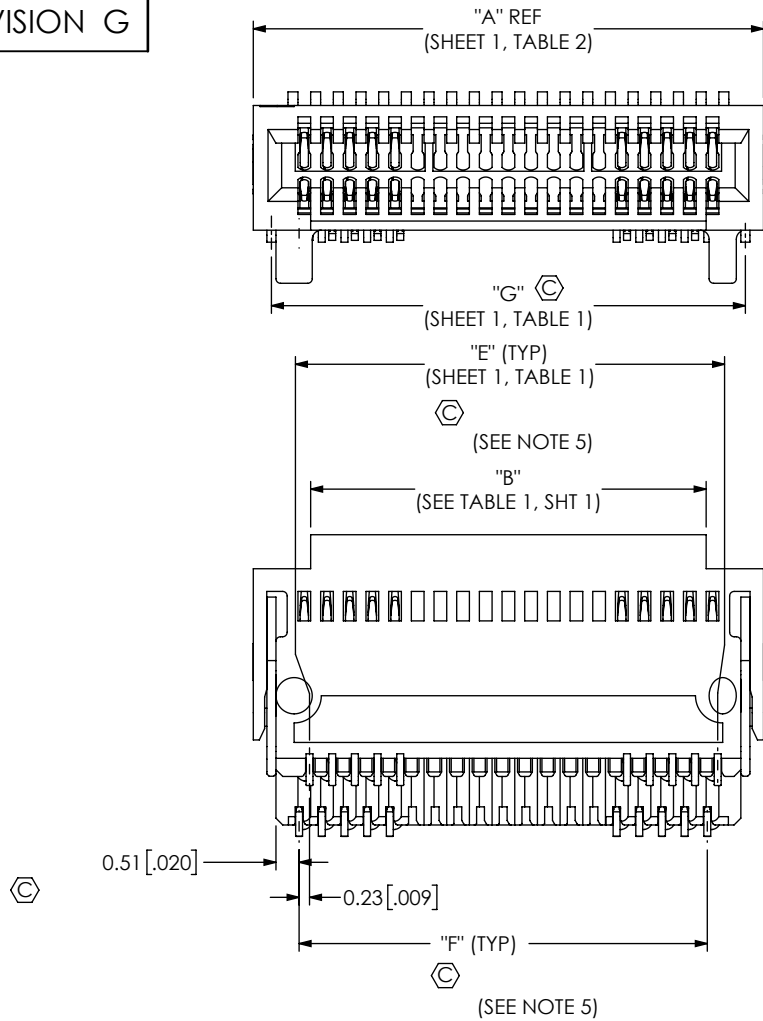

FIG 3
 UEC5-025-1-X-D-RA-2-A SHOWN
 (DIFFERENT AS SHOWN, OTHERWISE SAME AS FIG 1)
 (SOME CENTER FEATURES REMOVED FOR CLARITY)
 (PP NOT SHOWN FOR CLARITY)
 (NOT TOOLED)

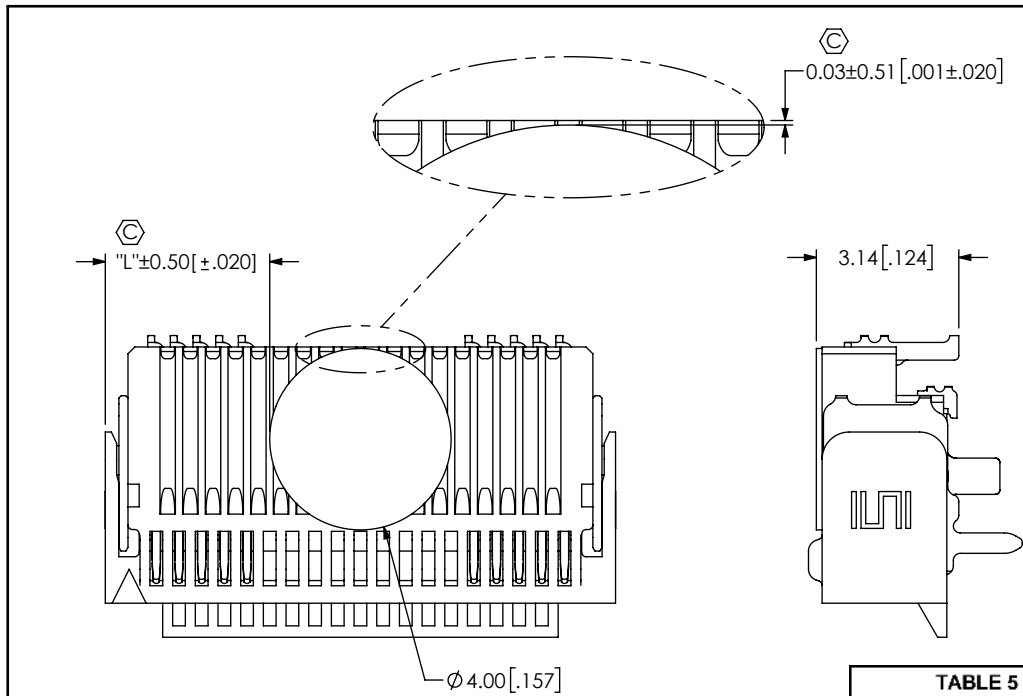
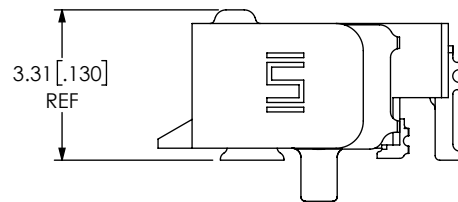

FIG 4
 POLYIMIDE PAD
 UEC5-019-1-X-D-RA-X-A SHOWN
 (USE K-DOT-.157-.250-.005)
 (DIFFERENT AS SHOWN, OTHERWISE SAME AS FIG 1)
 (SOME CENTER FEATURES REMOVED FOR CLARITY)
 (SEE NOTE 6)

No. OF POS	"L"
-019	3.62 [0.143]
*-025	5.12 [0.202]
*-038	9.00 [0.354]
*-050	12.00 [0.472]

(* = NOT TOOLED)

PROPRIETARY NOTE
 THIS DOCUMENT CONTAINS CONFIDENTIAL AND PROPRIETARY INFORMATION AND ALL DESIGN, MANUFACTURING, REPRODUCTION, USE, PATENT RIGHTS AND SALES RIGHTS ARE EXPRESSLY RESERVED BY SAMTEC, INC. THIS DOCUMENT SHALL NOT BE DISCLOSED, IN WHOLE OR PART, TO ANY UNAUTHORIZED PERSON OR ENTITY NOR REPRODUCED, TRANSFERRED OR INCORPORATED IN ANY OTHER PROJECT IN ANY MANNER WITHOUT THE EXPRESS WRITTEN CONSENT OF SAMTEC, INC.

DO NOT SCALE DRAWING
 SHEET SCALE: 6:1

samtec

520 PARK EAST BLVD, NEW ALBANY, IN 47150
 PHONE: 812-944-6733 FAX: 812-948-5047
 e-Mail info@SAMTEC.com code 55322

DESCRIPTION:
 0.5MM EDGE RATE SOCKET ASSEMBLY

DWG. NO.
 UEC5-XXX-1-X-D-RA-X-A

BY: KNOWLDEN 9/10/2013 SHEET 5 OF 5