

### TYPE 1

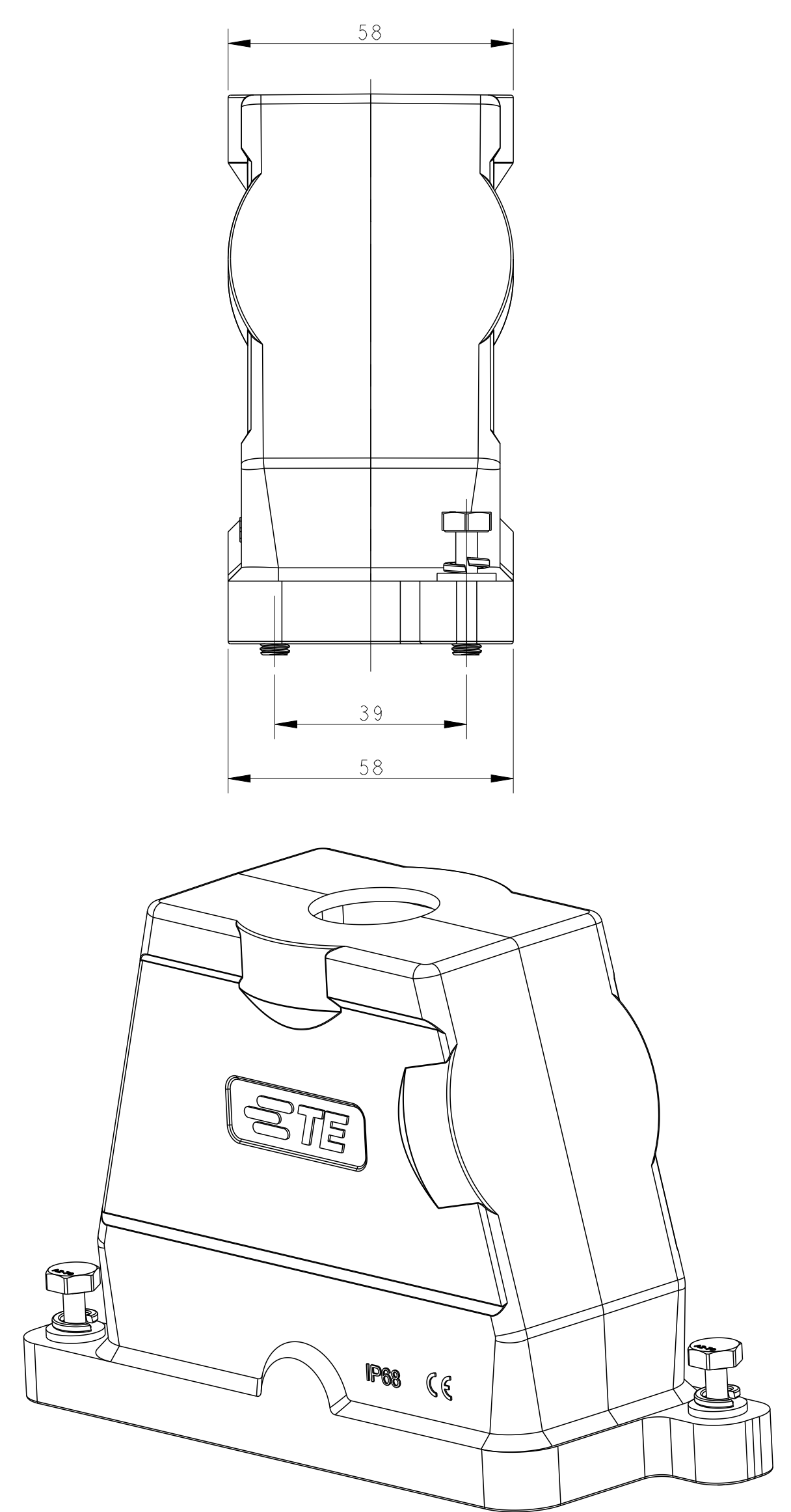

### TYPE 2

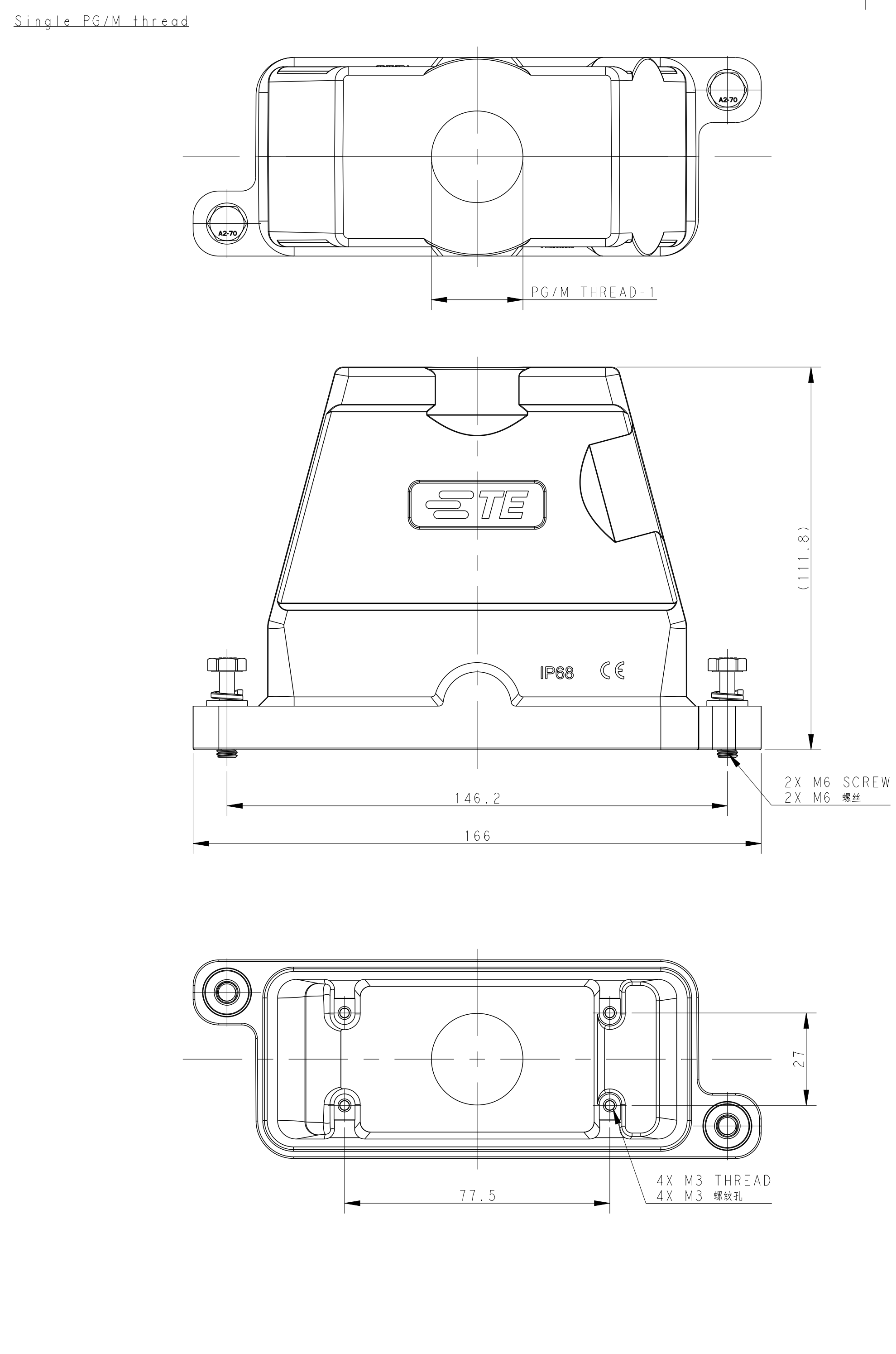
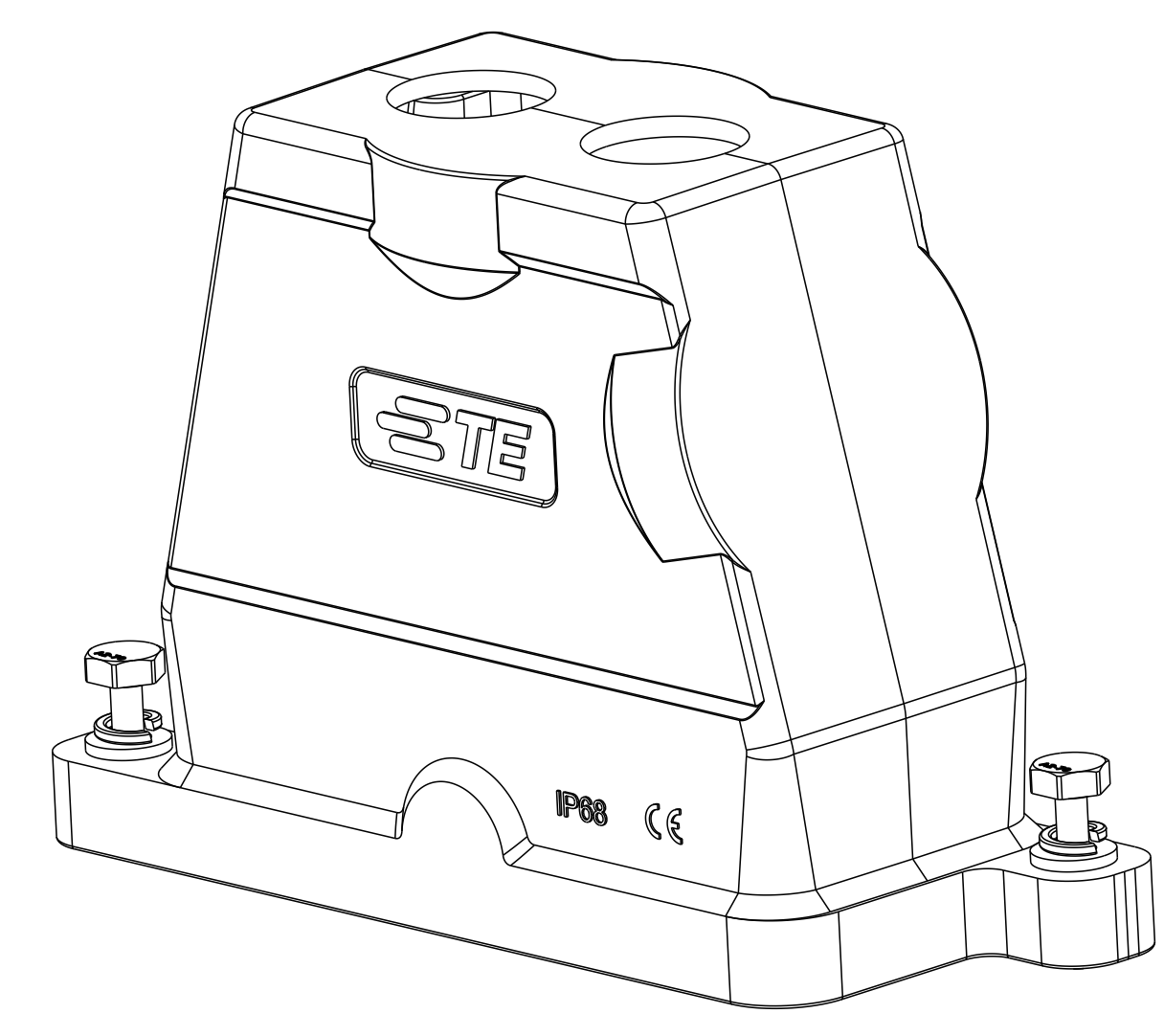
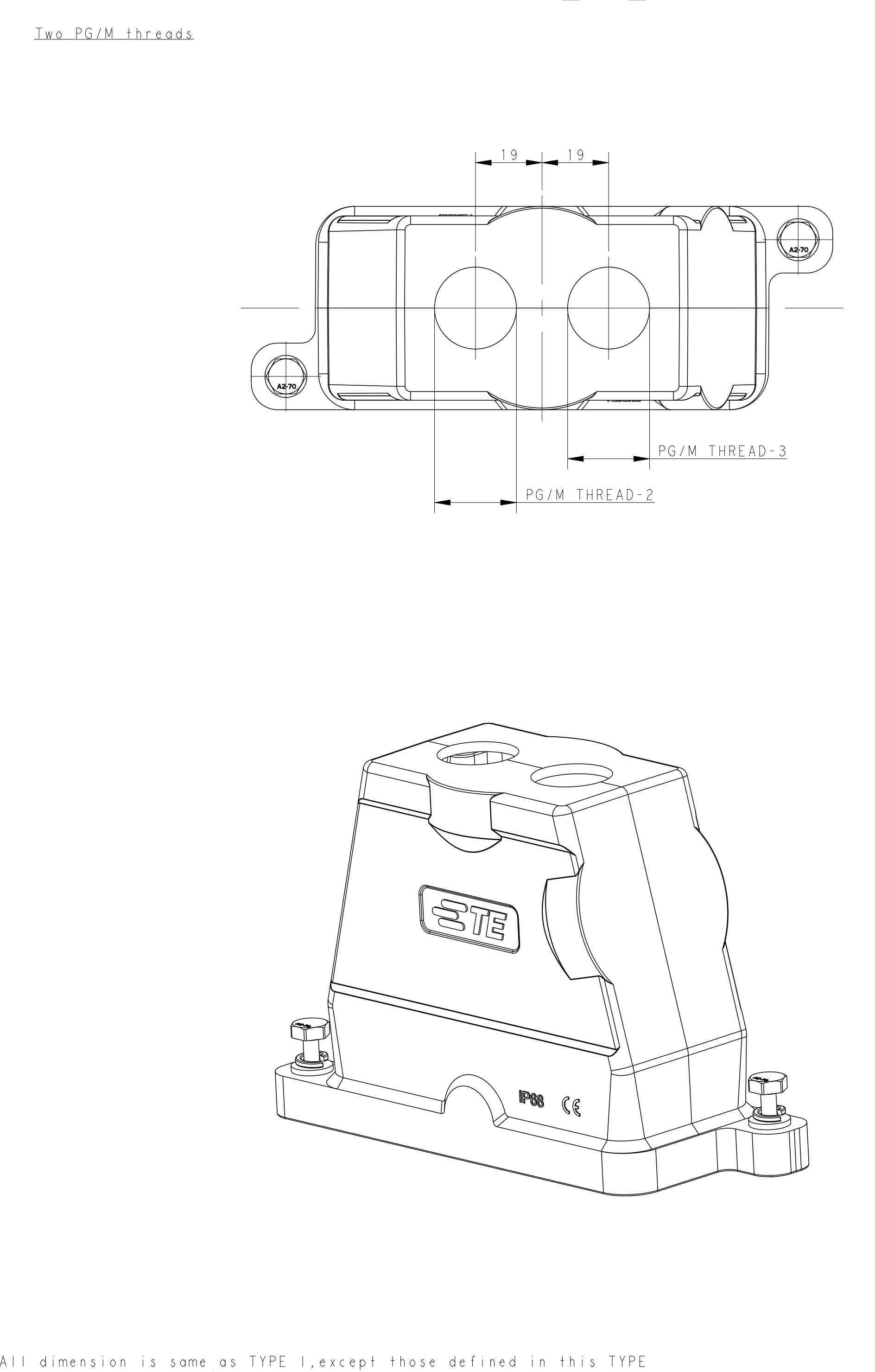

### TYPE 3

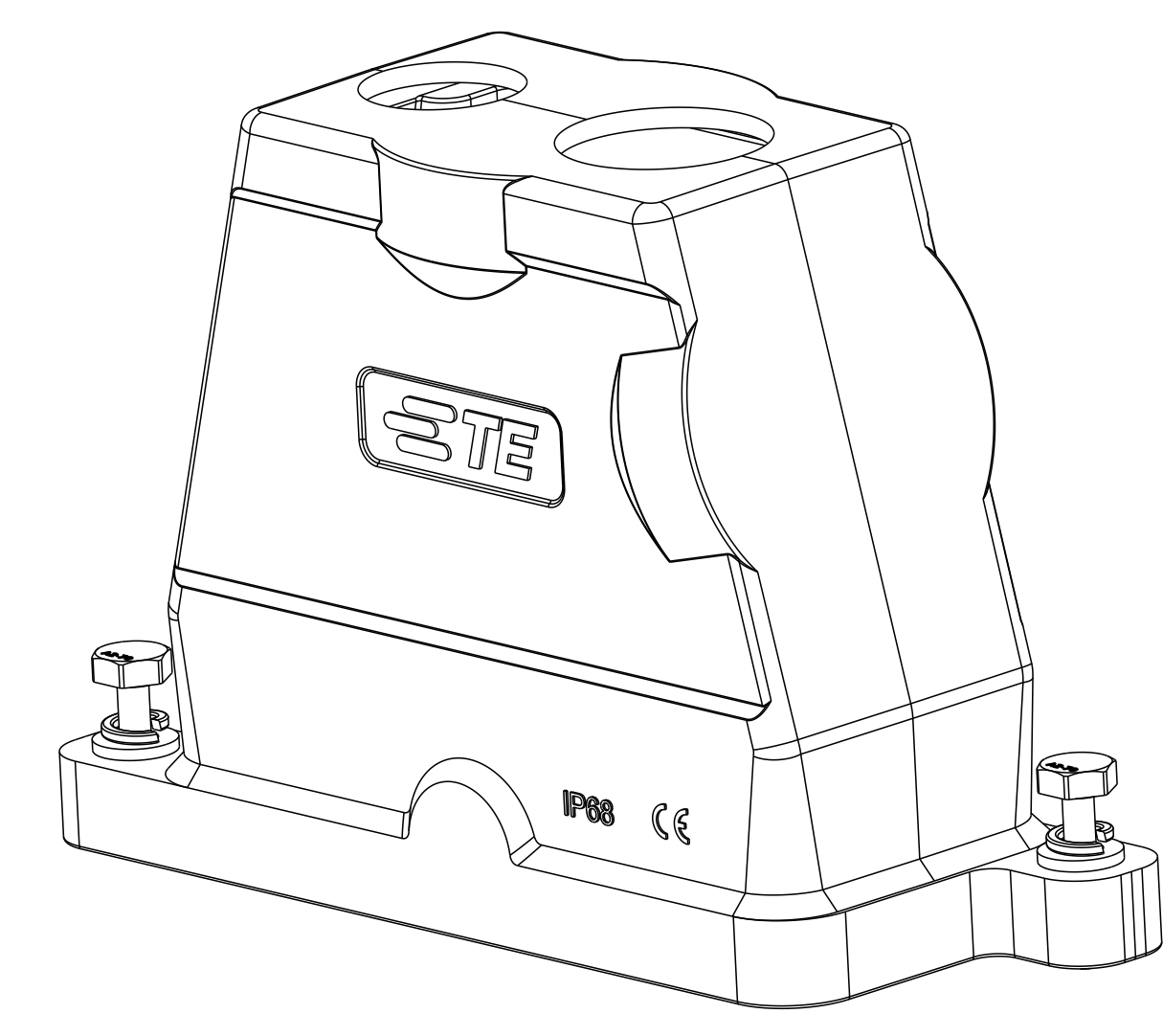
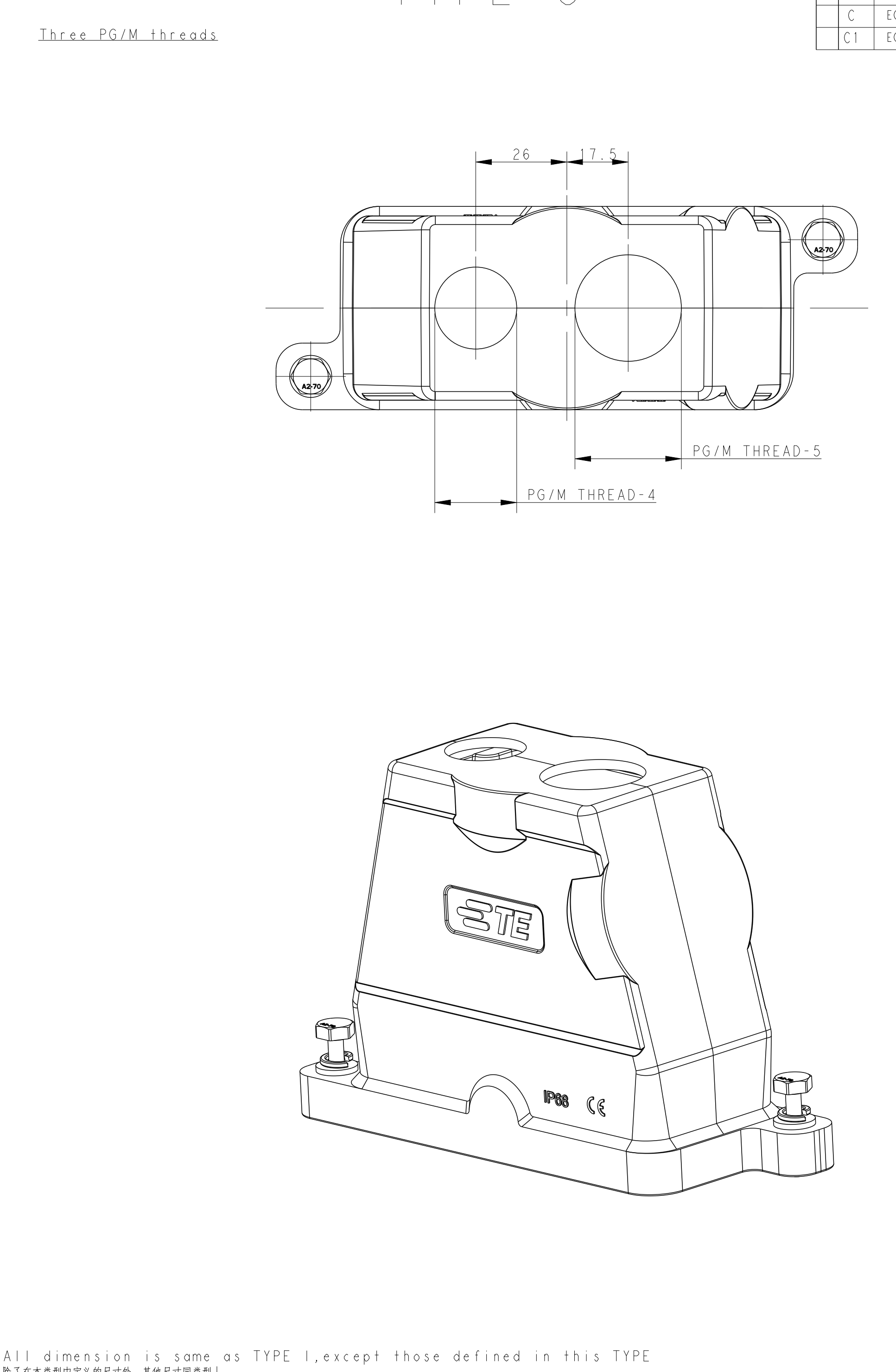

REVISIONS			
REV	DATE	BY	APPD
A	12SEP2016	DW	CW
B	23FEB2019	CD	CW
C	03JUN2021	BS	CW
C1	17FEB2022	BS	CW

All dimension is same as TYPE 1, except those defined in this TYPE  
 除了在本类型中定义的尺寸外,其他尺寸同类型1

All dimension is same as TYPE 1, except those defined in this TYPE  
 除了在本类型中定义的尺寸外,其他尺寸同类型1

NOTES:  
 1. TECHNICAL CHARACTERISTICS:  
 HOOD MATERIAL: DIE CAST ALUMINIUM ALLOY  
 SURFACE: SEE TABLE  
 DEGREE OF PROTECTION: IP68 (MATED)

过程:  
 1. 压铸成型:  
 金属材料: 铝合金  
 表面处理: 见表格  
 防护等级: IP68 (配合)

PART NUMBER	料号	PART DESCRIPTION	描述	PG/M THREAD-5	PG/M THREAD-4	PG/M THREAD-3	PG/M THREAD-2	PG/M THREAD-1	TYPE
T1920163225-109	H16BPR-TGH-M32/M25-EMC-C	H16BPR HOOD, DIAGONAL LOCKING, TOP ENTRY M32/M25, PASSIVATION+POWDER COATED, BLACK	H16BPR上盖, 对角锁定, 顶盖M32/M25, 钝化+黑色粉末喷涂	M32	M25	-	-	-	TYPE 3
T1920163225-009	H16BPR-TGH-M32/M25-EMC-C	H16BPR HOOD, DIAGONAL LOCKING, TOP ENTRY M32/M25, PASSIVATION+POWDER COATED, GREY	H16BPR上盖, 对角锁定, 顶盖M32/M25, 钝化+灰色粉末喷涂	M32	M25	-	-	-	类型3
T1920162516-009	H16BPR-TGH-M25/M16-EMC-C	H16BPR HOOD, DIAGONAL LOCKING, TOP ENTRY M25/M16, PASSIVATION+POWDER COATED, BLACK	H16BPR上盖, 对角锁定, 顶盖M25/M16, 钝化+黑色粉末喷涂	-	-	M16	M25	-	TYPE 2
T1920161225-009	H16BPR-TGH-2M25-EMC-C	H16BPR HOOD, DIAGONAL LOCKING, TOP ENTRY 2M25, PASSIVATION+POWDER COATED, SILVER WHITE	H16BPR上盖, 对角锁定, 顶盖2M25, 钝化+银色粉末喷涂	-	-	M25	M25	-	类型2
T1920160225-009	H16BPR-TGH-2M25-EMC-C	H16BPR HOOD, DIAGONAL LOCKING, TOP ENTRY 2M25, PASSIVATION+POWDER COATED, BLACK	H16BPR上盖, 对角锁定, 顶盖2M25, 钝化+黑色粉末喷涂	-	-	M25	M25	-	-
T1920161140-009	H16BPR-TGH-M40-EMC-C	H16BPR HOOD, DIAGONAL LOCKING, TOP ENTRY M40, PASSIVATION+POWDER COATED, SILVER WHITE	H16BPR上盖, 对角锁定, 顶盖M40, 钝化+银色粉末喷涂	-	-	-	-	M40	-
T1920161136-009	H16BPR-TGH-PG36-EMC-C	H16BPR HOOD, DIAGONAL LOCKING, TOP ENTRY PG36, PASSIVATION+POWDER COATED, SILVER WHITE	H16BPR上盖, 对角锁定, 顶盖PG36, 钝化+银色粉末喷涂	-	-	-	-	PG36	-
T1920161132-009	H16BPR-TGH-M32-EMC-C	H16BPR HOOD, DIAGONAL LOCKING, TOP ENTRY M32, PASSIVATION+POWDER COATED, SILVER WHITE	H16BPR上盖, 对角锁定, 顶盖M32, 钝化+银色粉末喷涂	-	-	-	-	M32	-
T1920161129-009	H16BPR-TGH-PG29-EMC-C	H16BPR HOOD, DIAGONAL LOCKING, TOP ENTRY PG29, PASSIVATION+POWDER COATED, SILVER WHITE	H16BPR上盖, 对角锁定, 顶盖PG29, 钝化+银色粉末喷涂	-	-	-	-	PG29	-
T1920161125-009	H16BPR-TGH-M25-EMC-C	H16BPR HOOD, DIAGONAL LOCKING, TOP ENTRY M25, PASSIVATION+POWDER COATED, SILVER WHITE	H16BPR上盖, 对角锁定, 顶盖M25, 钝化+银色粉末喷涂	-	-	-	-	M25	-
T1920161121-009	H16BPR-TGH-PG21-EMC-C	H16BPR HOOD, DIAGONAL LOCKING, TOP ENTRY PG21, PASSIVATION+POWDER COATED, SILVER WHITE	H16BPR上盖, 对角锁定, 顶盖PG21, 钝化+银色粉末喷涂	-	-	-	-	PG21	TYPE 1
T1920160140-009	H16BPR-TGH-M40-EMC-C	H16BPR HOOD, DIAGONAL LOCKING, TOP ENTRY M40, PASSIVATION+POWDER COATED, BLACK	H16BPR上盖, 对角锁定, 顶盖M40, 钝化+黑色粉末喷涂	-	-	-	-	M40	类型1
T1920160136-009	H16BPR-TGH-PG36-EMC-C	H16BPR HOOD, DIAGONAL LOCKING, TOP ENTRY PG36, PASSIVATION+POWDER COATED, BLACK	H16BPR上盖, 对角锁定, 顶盖PG36, 钝化+黑色粉末喷涂	-	-	-	-	PG36	-
T1920160132-009	H16BPR-TGH-M32-EMC-C	H16BPR HOOD, DIAGONAL LOCKING, TOP ENTRY M32, PASSIVATION+POWDER COATED, BLACK	H16BPR上盖, 对角锁定, 顶盖M32, 钝化+黑色粉末喷涂	-	-	-	-	M32	-
T1920160129-009	H16BPR-TGH-PG29-EMC-C	H16BPR HOOD, DIAGONAL LOCKING, TOP ENTRY PG29, PASSIVATION+POWDER COATED, BLACK	H16BPR上盖, 对角锁定, 顶盖PG29, 钝化+黑色粉末喷涂	-	-	-	-	PG29	-
T1920160125-009	H16BPR-TGH-M25-EMC-C	H16BPR HOOD, DIAGONAL LOCKING, TOP ENTRY M25, PASSIVATION+POWDER COATED, BLACK	H16BPR上盖, 对角锁定, 顶盖M25, 钝化+黑色粉末喷涂	-	-	-	-	M25	-
T1920160121-009	H16BPR-TGH-PG21-EMC-C	H16BPR HOOD, DIAGONAL LOCKING, TOP ENTRY PG21, PASSIVATION+POWDER COATED, BLACK	H16BPR上盖, 对角锁定, 顶盖PG21, 钝化+黑色粉末喷涂	-	-	-	-	PG21	-

THIS DRAWING IS A CONTROLLED DOCUMENT. DATE: 25SEP2016  
 DIMENSIONS: (mm) DAVID.WANG 25SEP2016  
 尺寸: (mm) CHRIS.WANG 25SEP2016  
 MATERIAL: 6061 ALUMINUM FINISH: ANODIZED WEIGHT: 114.137191  
 PRODUCT SPEC: 108-137191 APPLICATION SPEC: 114-137191  
 SCALE: 1:1 SHEET 1 OF 1 REV C1