

Type ESRE Solid Polymer Aluminum SMT Capacitors

Capacitance Tripled



Type ESRE capacitors triple the capacitance found in CDE's type ESRD capacitors.

Type ESRE polymer aluminum capacitors are low voltage polarized electrolytic capacitors, with extremely low equivalent series resistance at high frequency. This yields capacitors with very low high frequency impedance and higher ripple current capability than aluminum electrolytic or tantalum capacitors. One type ESRE capacitor can replace three or more tantalum or aluminum electrolytic capacitors. The solid electrolyte of the polymer aluminum capacitor gives it a long life that is ignition free.

Highlights

- Lowest ESR: <math><10\text{ m}\Omega</math> at 100 kHz
- 3.5 A ripple current at 100 kHz
- "D" case footprint: 7.3 (l) x 4.3 (w)
- Ignition Free

Applications

Motherboard By-Pass

Switching Supply Input/Output Filters

Power Supply Decoupling

High Frequency Noise Reduction

Laptop LCD Displays

Automotive Digital Equipment

Portable Electronic Equipment

Markings

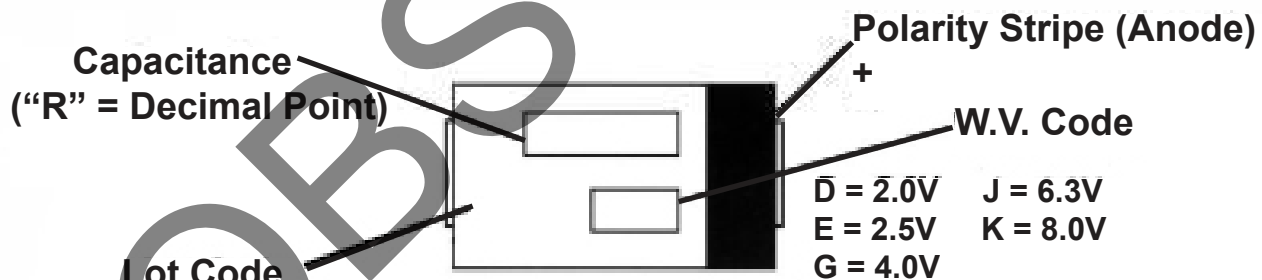

Ordering Information

ESRE

CDE Type

101

Capacitance Code
101 = 100 μ F

M

Capacitance Tolerance
M = \pm 20%

08

WVDC Code
02 = 2.0 Vdc 06 = 6.3 Vdc
0E = 2.5 Vdc 08 = 8.0 Vdc
04 = 4.0 Vdc

R

Packaging Code

R = Tape & Reel 2000 pcs/reel

Type ESRE Solid Polymer Aluminum SMT Capacitors

Surface Mount, High Capacitance

Outline Drawing

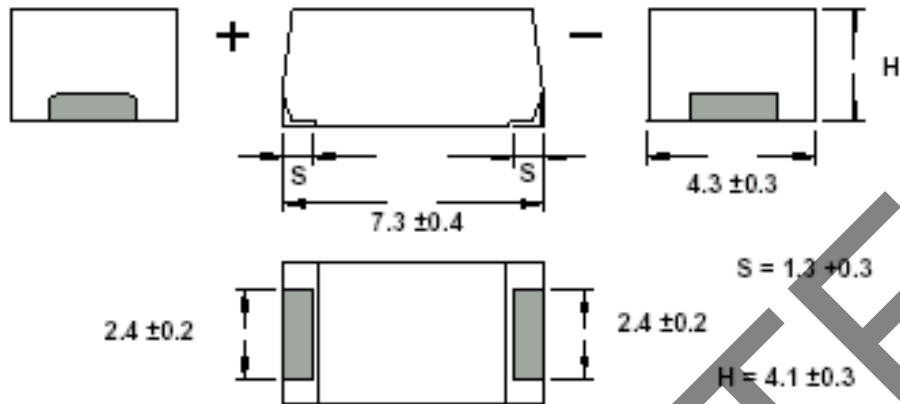

Ratings

| Capacitance (μF) | Catalog Part Number | Maximum E.S.R. 100 kHz/20 °C (Ω) | Maximum Ripple Current 100 kHz/105 °C (Amps) |
|----------------------------------|------------------------|--|---|
| 2.0 Vdc | | | |
| 270 | ESRE271M02R | 0.012 | 3.3 |
| 330 | ESRE331M02R | 0.012 | 3.3 |
| 390 | ESRE391M02XR | 0.010 | 3.5 |
| 2.5 Vdc | | | |
| 220 | ESRE221M0ER | 0.012 | 3.3 |
| 270 | ESRE271M0ER | 0.012 | 3.3 |
| 330 | ESRE331M0EXR | 0.010 | 3.5 |
| 4.0 Vdc | | | |
| 180 | ESRE181M04R | 0.012 | 3.3 |
| 220 | ESRE221M04XR | 0.010 | 3.5 |
| 6.3 Vdc | | | |
| 150 | ESRE151M06R | 0.012 | 3.3 |
| 180 | ESRE181M06XR | 0.010 | 3.5 |
| 8.0 Vdc | | | |
| 100 | ESRE101M08R | 0.012 | 3.3 |

Type ESRE Solid Polymer Aluminum SMT Capacitors

Specifications

Operating Temperature Range:

-55 °C to +105 °C, at 100% rated voltage

Surge Voltage:

125% of the rated working Vdc

Capacitance Range:

100 µF to 390 µF

Capacitance Tolerance:

±20% at 120 Hz and +20 °C

DC Leakage Current (DCL):

After a two minute application of the rated working voltage at +20 °C:

2V — 4V: $I \leq 0.06CV$

6.3V — 8V: $I \leq 0.04CV$ or 3 µA
(whichever greater)

Dissipation Factor (DF):

The ratio of the capacitor's equivalent series resistance to its reactance at 120Hz and +20 °C
ESRE: DF is 0.10 Max.

Resistance to Soldering Heat:

Heat the capacitors at 235 °C in an oven for 200 seconds. The capacitors will meet the following limits after stabilizing at 20 °C:

$\Delta C = \pm 10\%$ of the initial measured value

$DF \leq$ the initial specified value

$DCL \leq$ the initial specified value

Vibration:

No abnormal change shall occur to capacitors that have been soldered (and attached) to a board when subjected to a vibration of 1.5 mm amplitude that is varied from 10 Hz to 2000 Hz in 20 min. cycles. The test duration is 2 hours for each right angle direction (total 6 hours). Capacitance is monitored during the last cycle of the test for stability.

Moisture Resistance:

After 500 hours storage at +60 °C and 90% to 95% RH without load, the capacitor will meet the following limits:

$\Delta C = +70\%/-20\%$ of the initial measured value (2.0 Vdc, 2.5 Vdc),

+60%/-20% of the initial measured value (4.0 Vdc),

+50%/-20% of the initial measured value (6.3 Vdc),

+40%/-20% of the initial measured value (all other voltages)

$DF \leq$ two times the initial specified value

$DCL \leq$ the initial specified value

Life Test:

Apply rated DC working voltage at 105 °C for 1000 hours, and then stabilize them to +20 °C. Capacitors will meet the following limits:

$\Delta C = \pm 10\%$ of the initial measured value

$DF \leq$ the initial specified value

$DCL \leq$ the initial specified value

Shelf Life Test:

Shelf life is typically 42 months. Accelerated test: after 500 hours at 105 °C, capacitors will meet the following limits after stabilization at 20 °C:

$\Delta C = \pm 10\%$ of the initial measured value

$DF \leq$ the initial specified value

$DCL \leq$ the initial specified value

Shear Test:

No damage shall be visible after subjecting a mounted capacitor to a side force of 5 N for 10 seconds.

For more information on this product please see the Solid Polymer Aluminum Capacitors Application Guide

Type ESRE Solid Polymer Aluminum SMT Capacitors

Notice and Disclaimer: All product drawings, descriptions, specifications, statements, information and data (collectively, the "Information") in this datasheet or other publication are subject to change. The customer is responsible for checking, confirming and verifying the extent to which the Information contained in this datasheet or other publication is applicable to an order at the time the order is placed. All Information given herein is believed to be accurate and reliable, but it is presented without any guarantee, warranty, representation or responsibility of any kind, expressed or implied. Statements of suitability for certain applications are based on the knowledge that the Cornell Dubilier company providing such statements ("Cornell Dubilier") has of operating conditions that such Cornell Dubilier company regards as typical for such applications, but are not intended to constitute any guarantee, warranty or representation regarding any such matter – and Cornell Dubilier specifically and expressly disclaims any guarantee, warranty or representation concerning the suitability for a specific customer application, use, storage, transportation, or operating environment. The Information is intended for use only by customers who have the requisite experience and capability to determine the correct products for their application. Any technical advice inferred from this Information or otherwise provided by Cornell Dubilier with reference to the use of any Cornell Dubilier products is given gratis (unless otherwise specified by Cornell Dubilier), and Cornell Dubilier assumes no obligation or liability for the advice given or results obtained. Although Cornell Dubilier strives to apply the most stringent quality and safety standards regarding the design and manufacturing of its products, in light of the current state of the art, isolated component failures may still occur. Accordingly, customer applications which require a high degree of reliability or safety should employ suitable designs or other safeguards (such as installation of protective circuitry or redundancies or other appropriate protective measures) in order to ensure that the failure of an electrical component does not result in a risk of personal injury or property damage. Although all product-related warnings, cautions and notes must be observed, the customer should not assume that all safety measures are indicated in such warnings, cautions and notes, or that other safety measures may not be required.

OBSOLETE