



Pb Free

RoHS Comforming

Features

- Small and low profile
- Low insertion loss
- High Selectivity
- Withstanding High Voltage

Applications

- PCS
- GPS

How to Order

SF 16 - 1575 F 4 UU 01
① ② ③ ④ ⑤ ⑥ ⑦

- ① Series
- ② Package Size
- ③ Frequency
- ④ Application
- ⑤ Terminals
- ⑥ Input/Output Condition
- ⑦ Custom Specification

Dimensions

(Unit : mm)

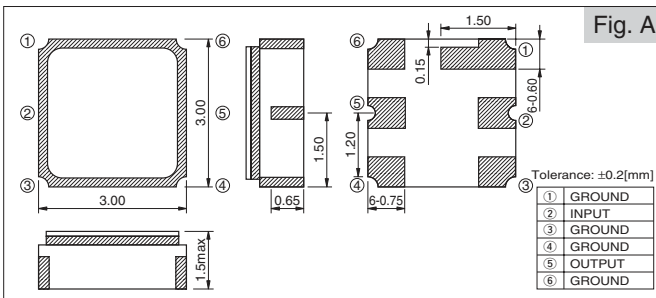

Fig. A

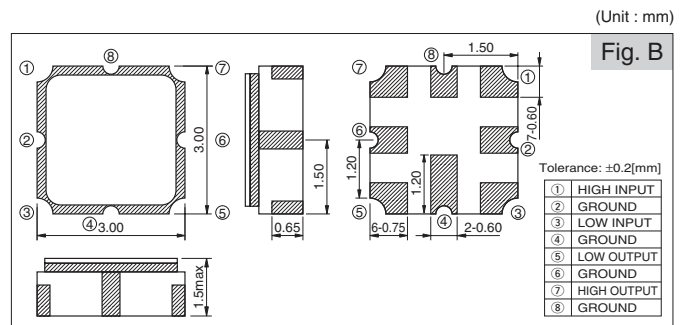
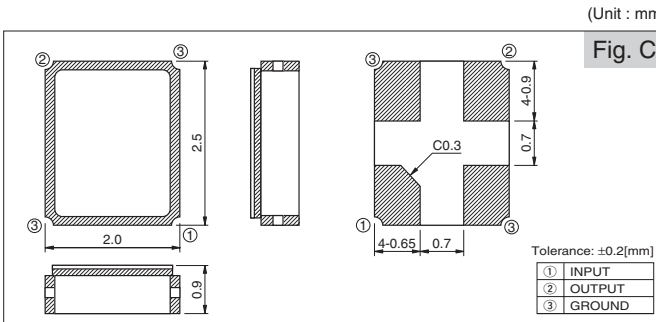
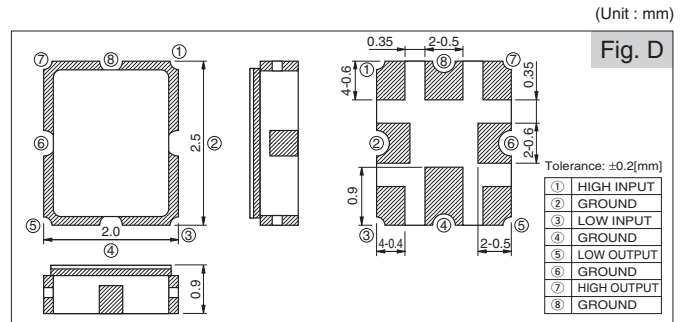

Fig. B



(Unit : mm)

Fig. C



(Unit : mm)

Fig. D

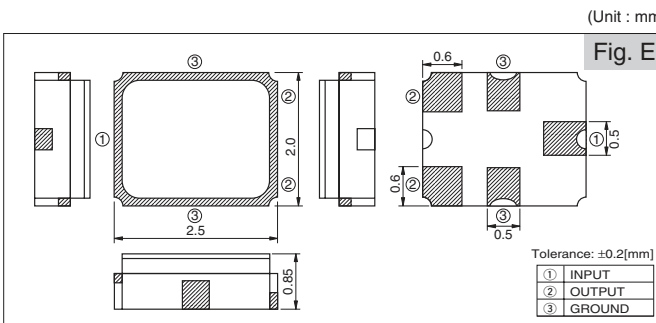

(Unit : mm)

Fig. E

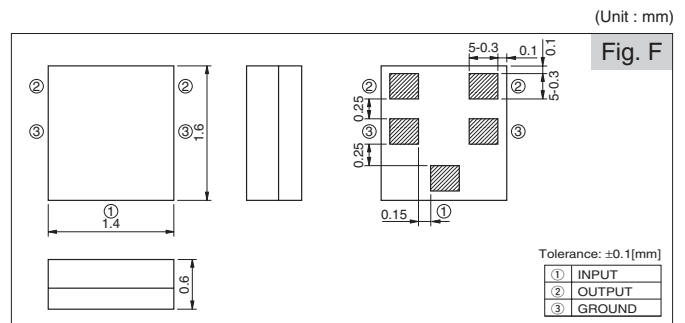

(Unit : mm)

Fig. F

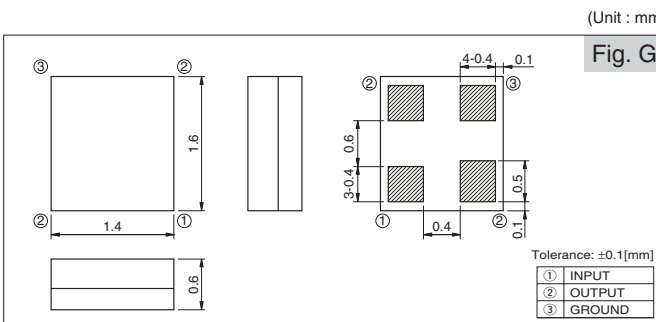

(Unit : mm)

Fig. G

Recommended Land Pattern

(Unit : mm)

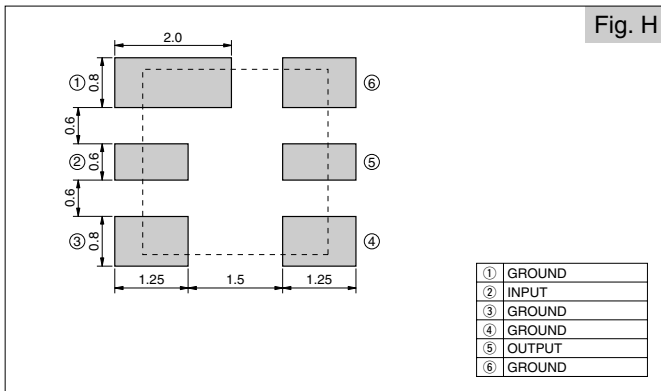

(Unit : mm)

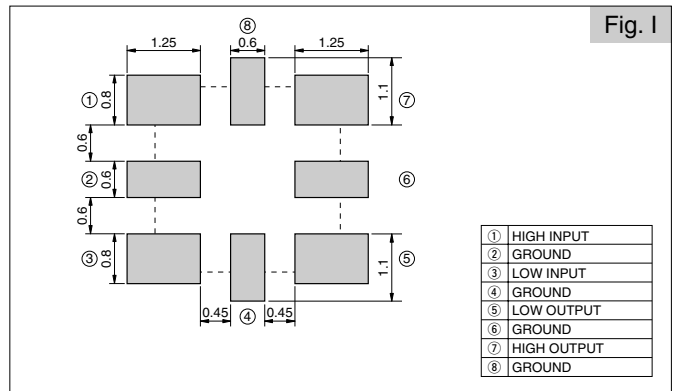

(Unit : mm)

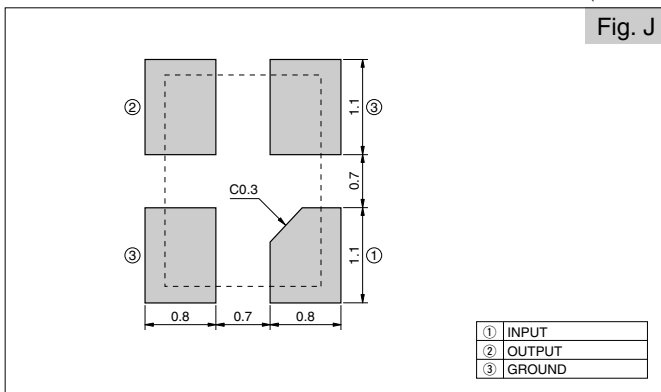

(Unit : mm)

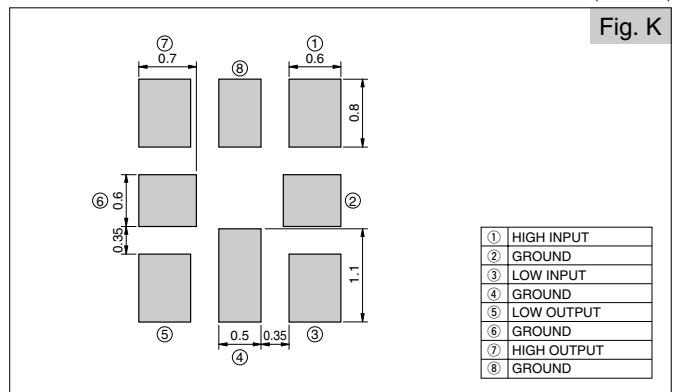

(Unit : mm)

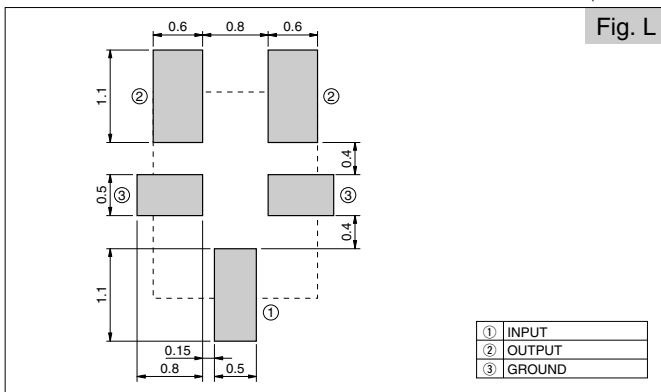

(Unit : mm)

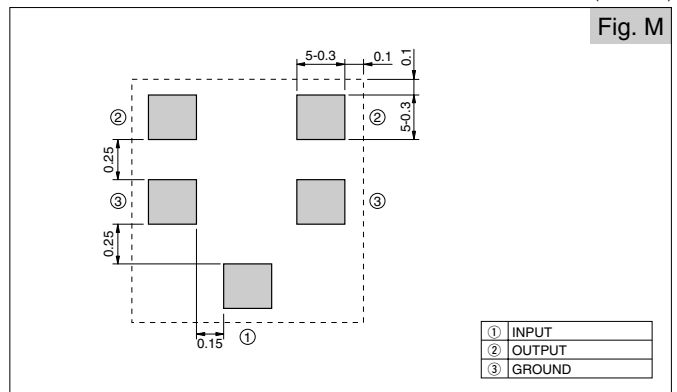

(Unit : mm)

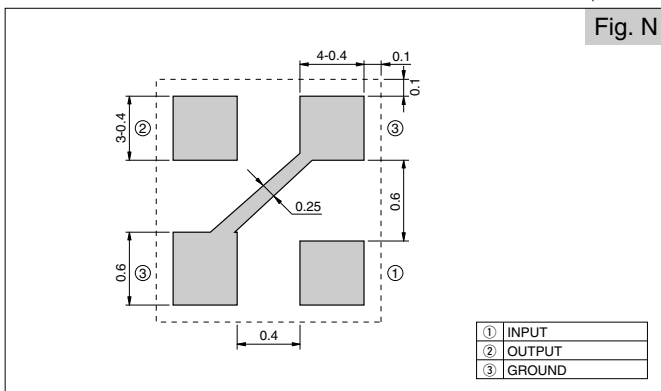

Specifications

Parts No.	Application		Pass Band Frequency	Pass Band Insertion Loss	Pass Band Variation	Pass Band VSWR	Absolute Rejection						Operating Temperature	Storage Temperature	Dimensions	Test Circuit	Recommended Land Pattern	Taping Dimensions
							0MHz	824MHz	915MHz	960MHz								
SF16-0881M5UB01	Cellular	Differential	869MHz 894MHz	3.0dB max	1.5dB max	2.5 max	0MHz 824MHz 35dB min	824MHz 849MHz 30dB min	915MHz 960MHz 23dB min	960MHz 3000MHz 40dB min					Fig. F	Fig. R	Fig. M	Dimensions 4
SF16-1575F4UU01	GPS	Front End	1573.92MHz 1576.92MHz	1.8dB max	1.0dB max	2.0 max	810MHz 960MHz 27dB min	1429MHz 1501MHz 37dB min	1893MHz 2170MHz 35dB min						Fig. G	Fig. Q	Fig. N	Dimensions 4
SF16-1575M4UU01	GPS	Inter Stage	1573.92MHz 1576.92MHz	1.8dB max	1.0dB max	2.5 max	810MHz 960MHz 35dB min	1208.22MHz 1210MHz 45dB min	1207MHz 1210MHz 45dB min	1522.42MHz 1628.42MHz 25dB min	1628.42MHz 1910MHz 35dB min	1850MHz 1910MHz 30dB min			Fig. G	Fig. Q	Fig. N	Dimensions 4
SF16-1960M5UB01	PCS	Differential	1930MHz 1990MHz	4.1dB max	2.0dB max	2.5 max	0MHz 1850MHz 30dB min	1850MHz 1910MHz 15dB min	2200MHz 2800MHz 25dB min	2800MHz 3400MHz 30dB min	2800MHz 3400MHz 30dB min	3400MHz 6000MHz 20dB min			Fig. F	Fig. R	Fig. M	Dimensions 4
SF25-0881M5UB02	Cellular	Differential	869MHz 894MHz	3.0dB max	1.5dB max	2.5 max	0MHz 824MHz 35dB min	824MHz 849MHz 30dB min	915MHz 960MHz 23dB min	960MHz 3000MHz 40dB min					Fig. E	Fig. R	Fig. L	Dimensions 3
SF25-1575F4UU01	GPS Single	Front End	1573.92MHz 1576.92MHz	1.8dB max	1.0dB max	2.0 max	810MHz 960MHz 27dB min	1429MHz 1501MHz 37dB min	1893MHz 2170MHz 35dB min						Fig. C	Fig. Q	Fig. J	Dimensions 3
SF25-1575M5UB01	GPS	Differential	1573.92MHz 1576.92MHz	1.8dB max	0.7dB max	2.5 max	0MHz 1475MHz 30dB min	1475MHz 1525MHz 10dB min	1625MHz 1675MHz 10dB min	1675MHz 3155MHz 30dB min	3155MHz 6000MHz 20dB min				Fig. E	Fig. R	Fig. L	Dimensions 3
SF25-1575S4UU01	GPS Single	Inter Stage	1573.92MHz 1576.92MHz	3.0dB max	1.0dB max	2.0 max	810MHz 960MHz 45dB min	1429MHz 1501MHz 40dB min	1895MHz 1916MHz 35dB min						Fig. C	Fig. Q	Fig. J	Dimensions 3
SF25-1880H8UU00	PCS (Half)	Tx(Low)	1850MHz 1880MHz	2.2dB max	1.5dB max	2.0 max	0MHz 1700MHz 20dB min	1700MHz 1760MHz 15dB min	1770MHz 1800MHz 15dB min	1930MHz 1960MHz 32dB min	2040MHz 2100MHz 25dB min	2100MHz 2500MHz 20dB min	-30 to +85°C	-40 to +85°C	Fig. D	Fig. P	Fig. K	Dimensions 3
		Tx(High)	1880MHz 1910MHz	2.2dB max	1.5dB max	2.0 max	0MHz 1700MHz 20dB min	1700MHz 1760MHz 15dB min	1800MHz 1830MHz 15dB min	1960MHz 1990MHz 32dB min	2040MHz 2100MHz 25dB min	2100MHz 2500MHz 20dB min						
SF25-1960M5UB01	PCS	Differential	1930MHz 1990MHz	4.1dB max	2.0dB max	2.5 max	0MHz 1850MHz 30dB min	1850MHz 1910MHz 15dB min	2200MHz 2800MHz 25dB min	2800MHz 3400MHz 30dB min	2800MHz 3400MHz 30dB min	3400MHz 6000MHz 20dB min			Fig. E	Fig. R	Fig. L	Dimensions 3
SF30-1575F6UU03	GPS Single	Front End	1573.92MHz 1576.92MHz	1.8dB max	1.0dB max	2.0 max	810MHz 958MHz 25dB min	1429MHz 1501MHz 25dB min	1687MHz 1893MHz 25dB min	1893MHz 1920MHz 25dB min	1920MHz 2170MHz 25dB min	2450MHz 18dB min			Fig. A	Fig. O	Fig. H	Dimensions 1
SF30-1575S6UU03	GPS Single	Inter Stage	1573.92MHz 1576.92MHz	3.0dB max	1.0dB max	2.0 max	DC 810MHz 25dB min	810MHz 958MHz 45dB min	1429MHz 1501MHz 40dB min	1701MHz 1920MHz 45dB min	1893MHz 1920MHz 40dB min	1920MHz 3000MHz 30dB min			Fig. A	Fig. O	Fig. H	Dimensions 1
SF30-1880M6UU00	PCS	Tx	1850MHz 1910MHz	4.5dB max	2.8dB max	2.5 max	1590MHz 1650MHz 20dB min	1720MHz 1780MHz 20dB min	1930MHz 1990MHz 7dB min	3400MHz 4800MHz 15dB min					Fig. A	Fig. O	Fig. H	Dimensions 1
SF30-1880H8UU00	PCS (Half)	Tx(Low)	1850MHz 1880MHz	3.0dB max	1.7dB max	2.3 max	0 1700MHz 20dB min	1700MHz 1760MHz 15dB min	1930MHz 1960MHz 32dB min	2200MHz 2700MHz 20dB min	2700MHz 3000MHz 7dB min		-30 to +85°C	-40 to +85°C	Fig. B	Fig. P	Fig. L	Dimensions 1
		Tx(High)	1880MHz 1910MHz	3.0dB max	1.7dB max	2.3 max	0 1700MHz 20dB min	1700MHz 1760MHz 15dB min	1960MHz 1990MHz 32dB min	2200MHz 2700MHz 20dB min	2700MHz 3000MHz 7dB min							
SF30-1960M6UU00	PCS	Rx	1930MHz 1990MHz	4.0dB max	2.8dB max	2.0 max	1509MHz 1780MHz 20dB min	1850MHz 1910MHz 10dB min	2100MHz 2375MHz 24dB min	3400MHz 4350MHz 10dB min					Fig. A	Fig. O	Fig. H	Dimensions 1

Characteristics

<GPS Single Front End>Parts No. : SF16-1575F4UU01

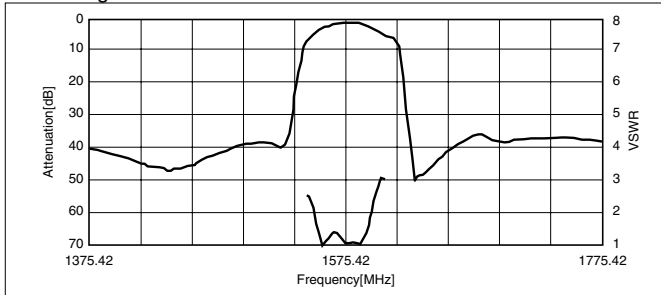

Pass Band Characteristics

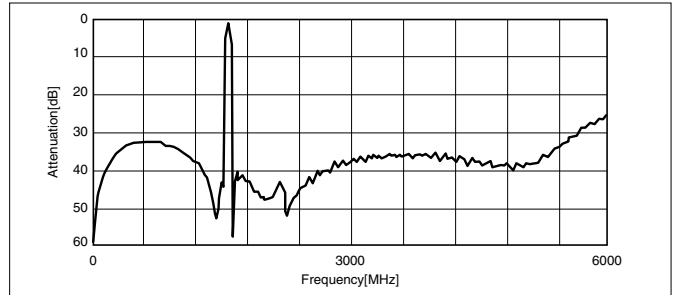

Spurious Characteristics

<GPS Single Inter Stage>Parts No. : SF16-1575M4UU01

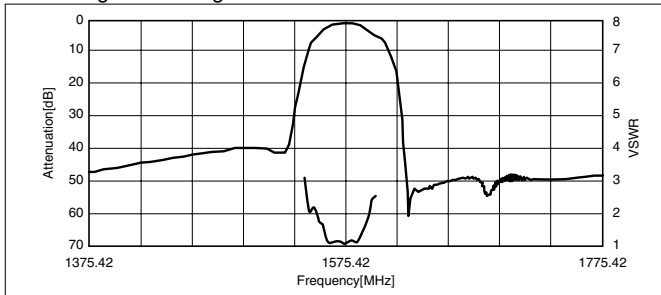

Pass Band Characteristics

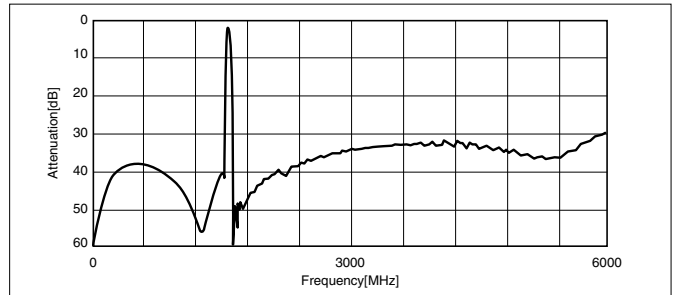

Spurious Characteristics

<GPS Single Front End>Parts No. : SF25-1575F4UU00

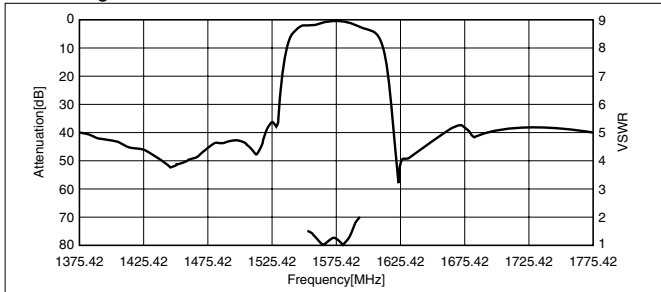

Pass Band Characteristics

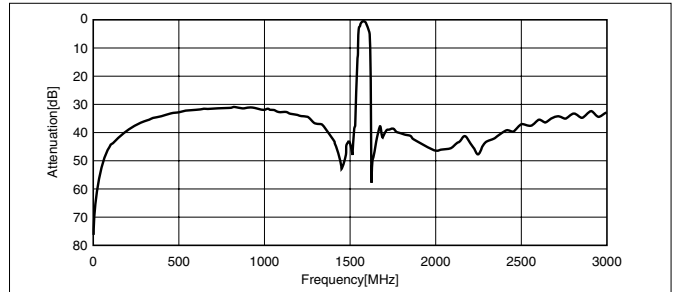

Spurious Characteristics

<GPS Single Inter Stage>Parts No. : SF25-1575S4UU00

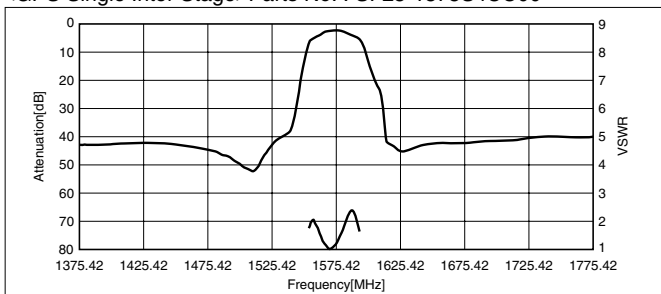

Pass Band Characteristics

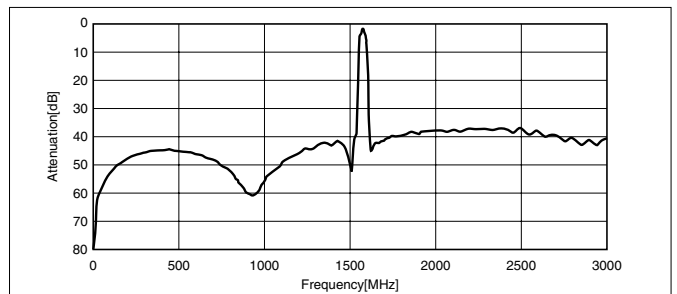

Spurious Characteristics

Characteristics

<Cellular Rx>Parts No. : SF16-0881M5UB01

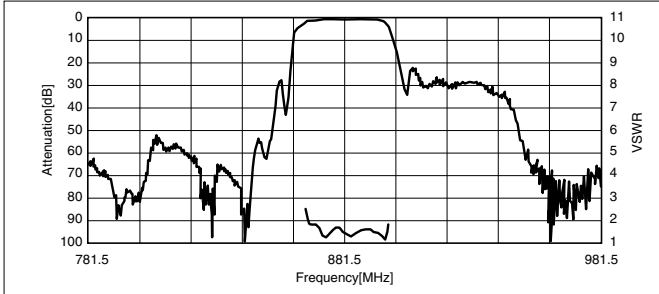

Pass Band Characteristics

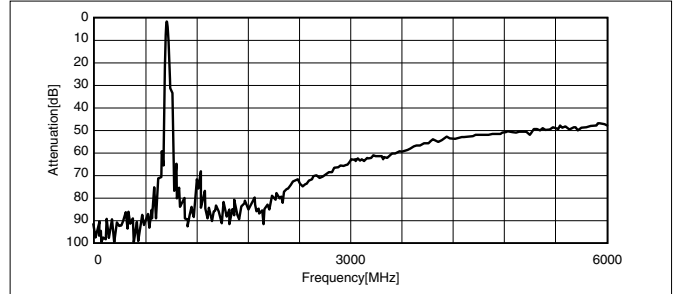

Spurious Characteristics

<PCS Rx>Parts No. : SF16-1960M5UB01

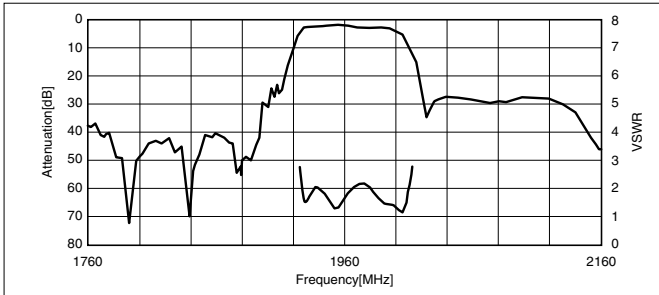

Pass Band Characteristics

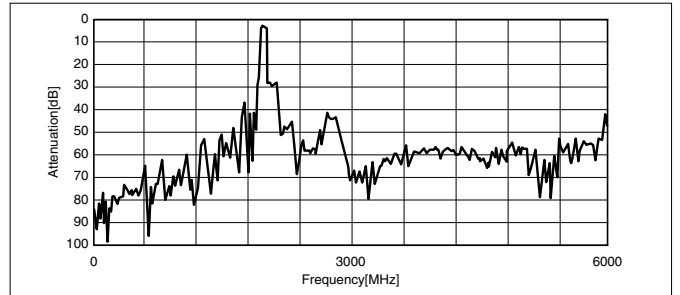

Spurious Characteristics

Test Circuit

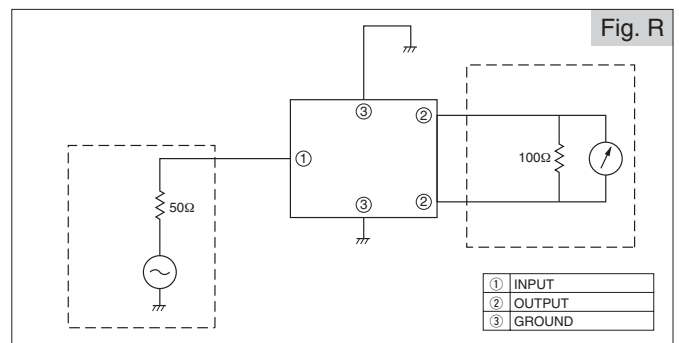
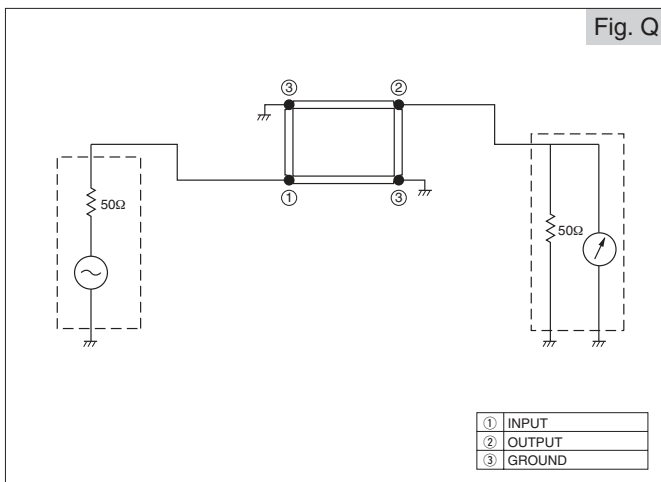
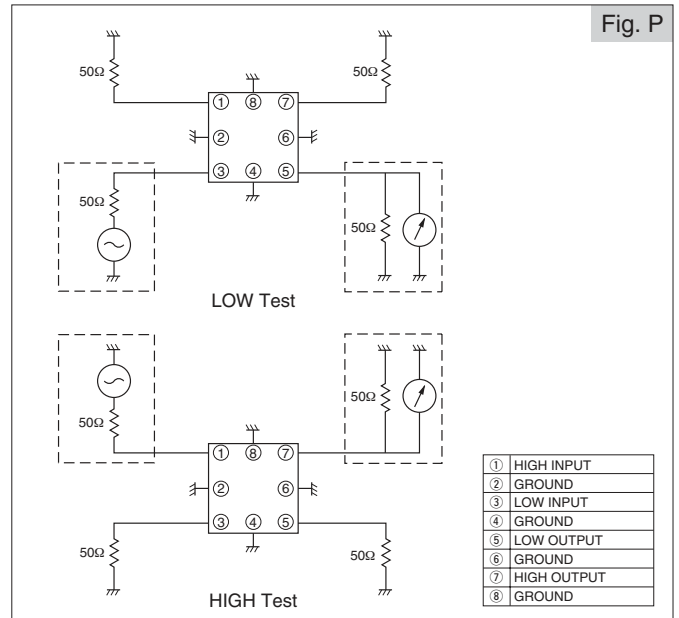
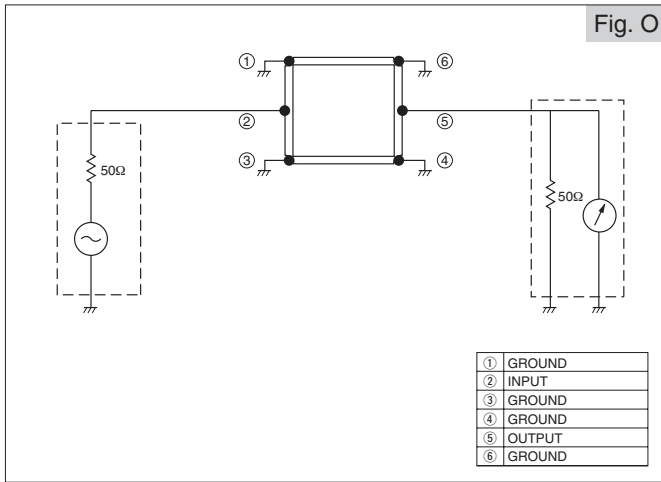

Recommended Temperature Profile IR Reflow

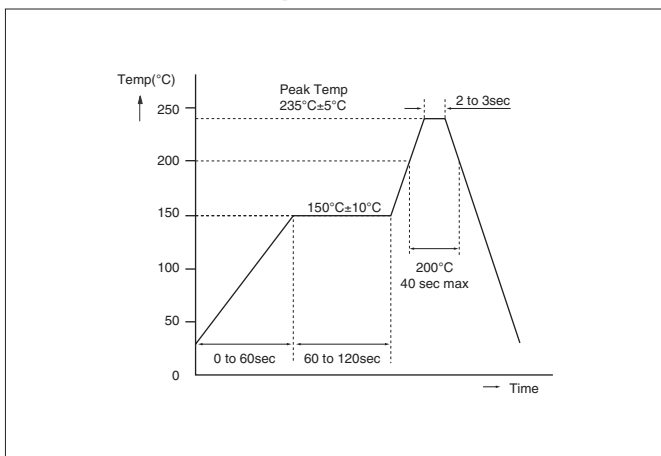

Taping Dimensions

(Unit : mm)

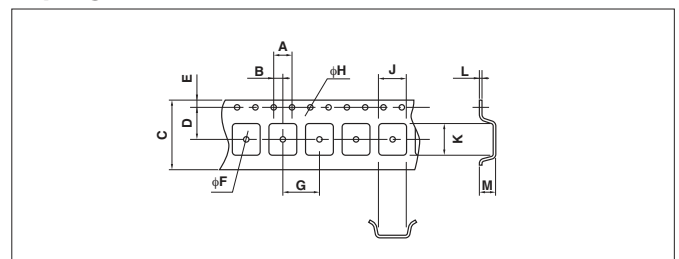

Code	A	B	C	D	F	G	H	J	K	L	M
Dimensions1	4.0	2.0	12.0	5.5	1.55	8.0	1.55	3.3	3.3	0.3	1.85
Dimensions2	4.0	2.0	12.0	5.5	1.55	8.0	1.55	4.0	4.0	0.3	1.40
Dimensions3	4.0	2.0	12.0	5.5	1.10	4.0	1.55	2.4	2.9	0.3	1.20
Dimensions4	4.0	2.0	8.0	3.5	1.10	4.0	1.50	1.7	1.8	0.25	0.85

Characteristic diagram and terms of crystal filters

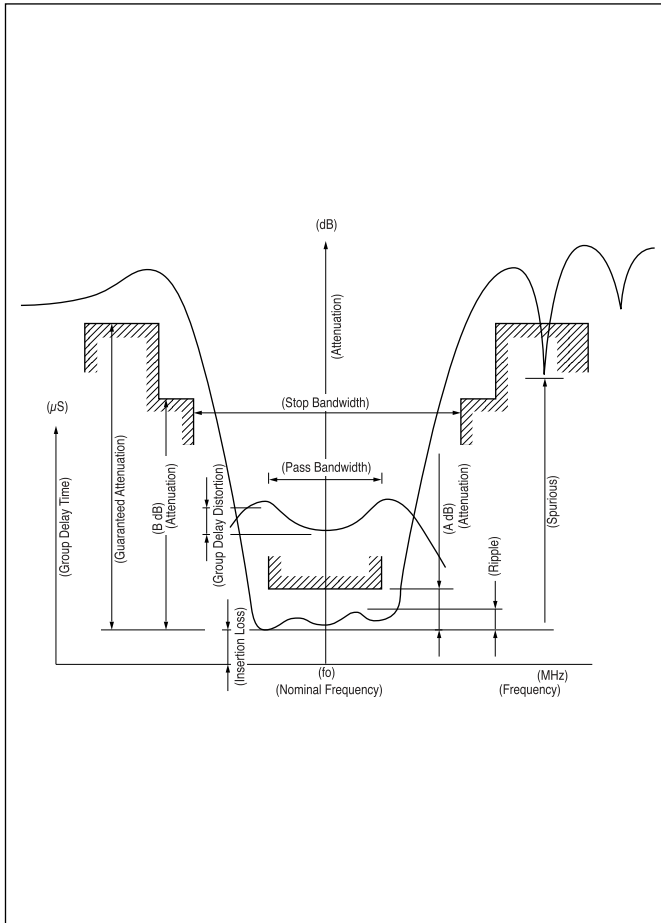

■Nominal Frequency

This is the nominal value of the center frequency (f_0) and is used as the reference frequency of related standards.

■Pass Bandwidth

This is the frequency interval in which the relative attenuation (the attenuation from the minimum insertion loss) is equal to the specified value "A dB" (Usually 3dB).

■Insertion Loss

This is the difference of attenuation when a filter is and isn't inserted. The minimum insertion loss is the minimum value of insertion loss and becomes as the reference level of attenuation characteristics specification. The constant loss is the insertion loss at the nominal frequency.

■Ripple

This is the maximum value of the difference between the peak value of attenuation in the pass band and the minimum insertion loss.

■Stop Bandwidth

This is the frequency interval in which the relative attenuation is equal to the specified value "B dB".

■Guaranteed Attenuation

This is the relative attenuation guaranteed in the specified range within attenuation band scope.

■Spurious Response

This is the value of relative attenuation generated by the secondary vibration in the specified range within attenuation band scope.

■Group Delay Time

This is the difference between the maximum and the minimum value of the group delay in the specified range of the pass band.

■Terminating Impedance

This is the impedance value terminated to the input and the output side of filter and is indicated by the resistance portion and the parallel capacity portion including the floating capacity.

ORDERING FORMAT for CRYSTAL FILTERS

Please specify the following items when ordering crystal filters.

I. Standard product in catalog Indicate type name.

for example : MXF10.7-6A

II. Indicate following items in specification if you order special type.

1. Electrical Characteristics

- | | |
|---------------------------|-------------------------------------|
| (1)Nominal Frequency | _____MHz |
| (2)Pass Bandwidth | at_____dB ±_____kHz MIN. |
| (3)Stop Bandwidth | at_____dB ±_____kHz MAX. |
| (4)Guaranteed Attenuation | _____dB MINn. ($f_0 \pm$ _____kHz) |
| (5)Spurious Response | _____dB MIN. |
| (6)Ripple | _____dB MAX. |
| (7)Insertion Loss | _____dB MAX. |
| (8)Terminating Impedance | _____Ω//_____pF |

2. Environmental Condition

- (1)Operating Temperature Range _____°C ~ _____°C

3. Dimensions _____

4. Application _____

Tape & Reel Specifications

SAW FILTERS / MCFs

		SAW FILTERS			
		SF16	SF25	SF30	
T A P E	A	2.0±0.05	2.0±0.05	2.0±0.05	
	B	4.0±0.1	4.0±0.1	4.0±0.1	
	C	φ1.5±0.1	φ1.55±0.1/-0	φ1.55±0.1/-0	
	D	4.0±0.1	4.0±0.1	8.0±0.1	
	E	3.5±0.05	5.5±0.05	5.5±0.05	
	F	1.75±0.1	1.75±0.1	1.75±0.1	
	G	8.0±0.2	12.0±0.2	12.0±0.2	
	H	φ1.1±0.1	φ1.1±0.1	φ1.55±0.1	
	J	1.9±0.1	2.9±0.1	3.3±0.1	
	L	1.85±0.1	2.4±0.1	3.3±0.1	
	N	0.95±0.1	1.2±0.1	1.85±0.1	
	O	0.25±0.05	0.3±0.05	0.3±0.05	
	R E E L	P	φ178±2	φ330±2	φ330±2
		Q	φ80±2	φ100±2	φ100±2
R		φ13±0.2	φ13±0.2	φ13±0.2	
S		φ21±0.8	φ21±0.8	φ21±0.8	
U		2±0.5	2±0.5	2±0.5	
W		13.5±1	13.5±1	13.5±1	
Qty		3000	3000	3000	

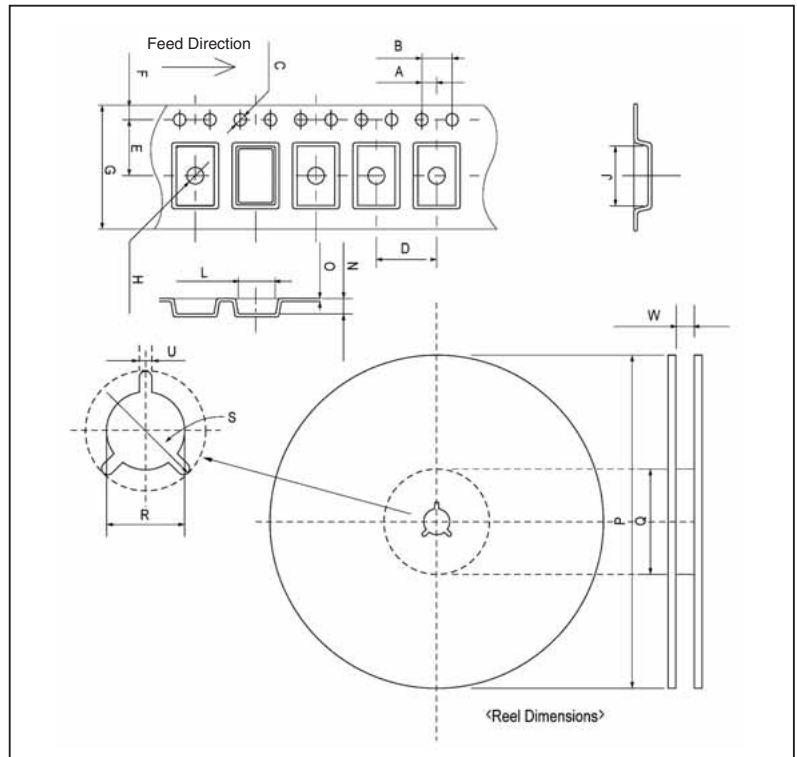

		SAW FILTERS								MCF	
		PAFA	PAFC243B	PAFC433.92A	B54	B22 B43	B19 B25	C12 C30	B44	FP2 FP4	
T A P E	A	2.0±0.05	2.0±0.05	2.0±0.05	2.0±0.10	2.0±0.10	2.0±0.05	2.0±0.10	2.0±0.10	2.0±0.1	
	B	4.0±0.1	4.0±0.1	4.0±0.1	4.0±0.1	4.0±0.1	4.0±0.1	4.0±0.1	4.0±0.1	4.0±0.1	
	C	φ1.55±0.05	φ1.5±0.1/-0	φ1.5±0.1/-0	φ1.55±0.05	φ1.55±0.05	φ1.55±0.05	φ1.55±0.05	φ1.55±0.05	φ1.55±0.05	
	D	8.0±0.1	8.0±0.1	8.0±0.1	8.0±0.1	8.0±0.1	8.0±0.1	8.0±0.1	8.0±0.1	8.0±0.1	
	E	5.5±0.05	5.5±0.05	5.5±0.05	5.5±0.1	7.5±0.1	5.5±0.05	7.5±0.1	5.5±0.05	7.5±0.1	
	F	1.75±0.1	1.75±0.1	1.75±0.1	1.75±0.1	1.75±0.1	1.75±0.1	1.75±0.1	1.75±0.1	1.75±0.1	
	G	12.0±0.2	12.0±0.2	12.0±0.3	12.0±0.3	16.0±0.3	12.0±0.15	16.0±0.3	12.0±0.2	16.0±0.3	
	H	φ1.55±0.05	φ1.55±0.1	φ1.55±0.1	φ1.5±0.05/-0	φ1.55±0.05	φ1.55±0.05	φ1.55±0.05	φ1.55±0.05	φ1.55±0.05	
	J	3.3±0.1	4.3±0.1	5.3±0.1	5.25±0.1	9.4±0.1	4.2±0.1	7.6±0.1	3.95±0.2	7.5±0.1	
	L	3.3±0.1	4.3±0.1	5.3±0.1	3.45±0.1	5.1±0.1	4.2±0.1	5.6±0.1	3.95±0.2	5.5±0.1	
	N	1.85±0.1	2.05±0.1	2.1±0.1	1.5±0.1/-0	2.0±0.1	1.8±0.1	1.94±0.1	1.35±0.1	1.8±0.1	
	O	0.3±0.05	0.3±0.05	0.3±0.05	0.3±0.1	0.3±0.05	0.3±0.05	0.3±0.05	0.2±0.05	0.3±0.05	
	R E E L	P	φ255±2	φ255±2	φ255±2	φ330±1	φ330±1	φ178±2	φ330±1	φ178±2	φ178±2
		Q	φ100±2	φ80±2	φ80±2	φ100±1	φ100±1	φ80±1	φ100±1	φ80±1	φ80±2
R		φ13±0.2	φ13±0.2	φ13±0.2	φ13±0.3	φ13±0.3	φ13±0.5	φ13±0.3	φ13±0.5	φ13±0.5	
S		φ21±0.8	φ21±0.8	φ21±0.8	φ21±0.5	φ21±0.5	φ21±0.5	φ21±0.5	φ21±0.5	φ21±0.8	
U		2±0.5	2±0.5	2±0.5	2±0.5	2±0.5	2±0.5	2±0.5	2±0.5	2±0.5	
W		13.5±1	13.5±1	13.5±1	12.4±2/-0	16.4±0.5	13.5±2/-0	16.4±0.5	13.5±2/-0	17.5±1/-0.5	
Qty		2000	2000	2000	3000	3000	1000	3000	1000	1000	