

Data Sheet

Description

The HSMR-CL25 series of parts is designed with an ultra small form factor to allow this miniaturization. The HSMR-CL25 series is the thinnest available top emitting package in the market with high brightness InGaN die technology. The leadframe construction of this package allows the part to transfer heat from the package, thus it is able to survive temperature conditions of -40°C to 85°C despite its small size.

The target applications are Keypad backlighting, Push button backlighting and Status indicators.

The target markets are Mobile Handsets, Communications, Office Automation, Industrial and Commercial automations, Home Market appliances, Networking, Medical Instruments, and Mobile Computing. This product is competitively priced, and production is geared towards short lead times and ample capacity.

Features

- Small size top firing
- Small 1.6 (L) x 0.8 (W) x 0.25 (H) mm package
- Compatible with IR Reflow
- High brightness using InGaN die technology
- Available in 8mm Tape on 7" (178 mm) Diameter Reels

Advantages

- High package thermal dissipation capability due to the superior package leadframe design
- Small footprint to overcome space count
- Low thickness to overcome space constrains
- Short lead times and competitive pricing

Package Dimensions

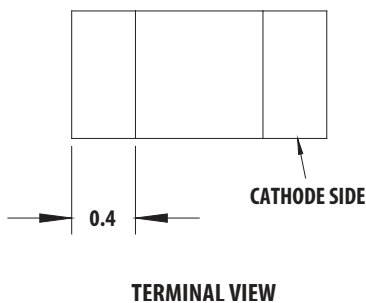
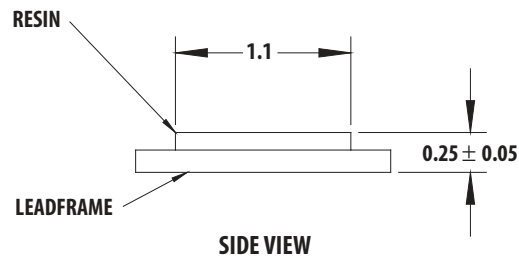
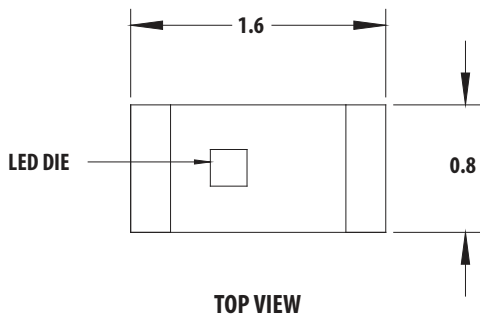

Notes:

1. All dimensions are in millimeters.
2. Tolerance is ± 0.1 mm unless otherwise specified.

CAUTION: HSMR-CL25 LEDs are Class 1B ESD sensitive per JESD22-A114C.01. Please observe appropriate precautions during handling and processing. Refer to Application Note AN-1142 for additional details.

Device Selection Guide

Package Dimension (mm)	Die Technology	Colors	Testing Current (mA)	Parts per Reel	Package Description
1.6 (L) x 0.8 (W) x 0.25 (H)	InGaN	Blue	5	4000	Untinted, Diffused

Absolute Maximum Ratings at TA = 25°C

Parameter	HSMR-CL25	Units
DC Forward Current ^[1]	10	mA
Power Dissipation	39	mW
Reverse Voltage (IR = 100μA)	5	V
LED Junction Temperature	95	°C
Operating Temperature Range	-40 to +85	°C
Storage Temperature Range	-40 to +85	°C
Soldering Temperature	See reflow soldering profile (Refer to Figures 7 & 8)	

Notes:

1. Derate linearly as shown in Figure 4.

Electrical Characteristics at TA = 25°C

Part Number	Forward Voltage VF (Volts) ^[1] @ IF = 5mA		Reverse Breakdown VR (Volts) @ IR = 100μA	Thermal Resistance RθJ-PIN (°C/W)
	Typ.	Max.	Min.	Typ.
HSMR-CL25	2.85	3.15	5	300

Notes:

1. Vf tolerance : ±0.1V

Optical Characteristics at TA = 25°C

Part Number	Luminous Intensity IV ^[1] (mcd) @ 5mA		Peak Wavelength λ _{peak} (nm)	Dominant Wave- length λ _d ^[2] (nm)	Viewing Angle ^[3] (°)
	Min.	Typ.	Typ.	Typ.	Typ.
HSMR-CL25	11.2	18	469	473	120

Notes:

1. The luminous intensity IV is measured at the peak of the spatial radiation pattern which may not be aligned with the mechanical axis of the LED package.
2. The dominant wavelength, λ_d, is derived from the CIE Chromaticity Diagram and represents the perceived color of the device.
3. θ_{1/2} is the off-axis angle where the luminous intensity is 1/2 the peak intensity.

Light Intensity (IV) Bin Limits

Bin ID	Intensity (mcd)	
	Minimum	Maximum
L	11.20	18.00
M	18.00	28.50
N	28.50	45.00

Tolerance : ±15%

Color Bin Limits

Bin ID	Dominant Wavelength (nm)	
	Minimum	Maximum
B	465.0	470.0
C	470.0	475.0

Tolerance : ±1nm

Forward Voltage (VF) Bin Limits

Bin ID	Forward Voltage (V)	
	Minimum	Maximum
1	2.55	2.75
2	2.75	2.95
3	2.95	3.15

Tolerance : ±0.1V

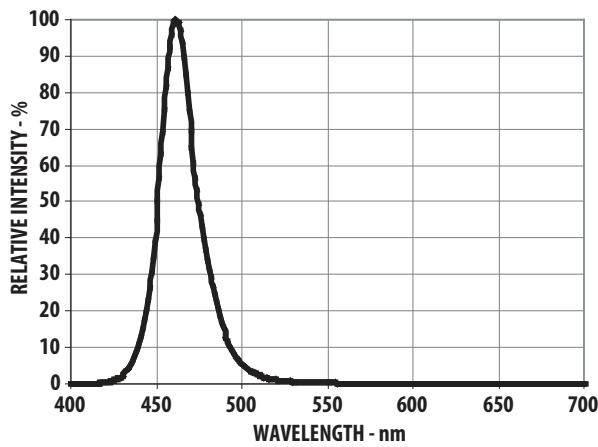

Figure 1. Relative intensity vs. wavelength

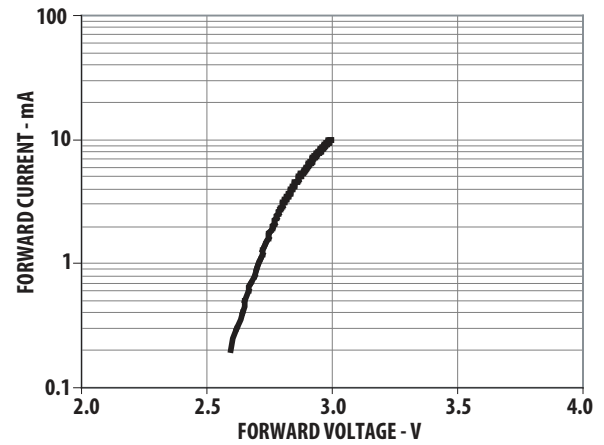

Figure 2. Forward voltage vs. forward current

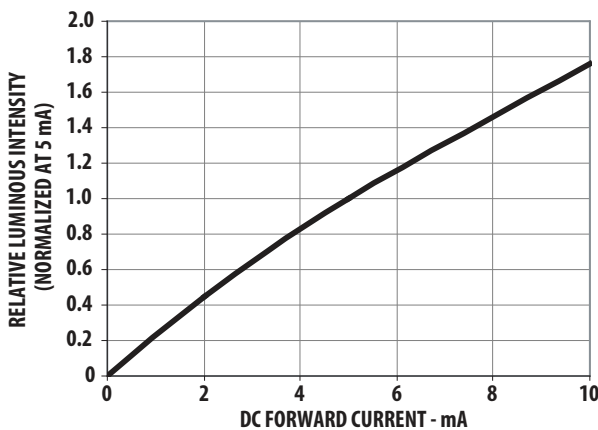

Figure 3. Luminous intensity vs. forward current

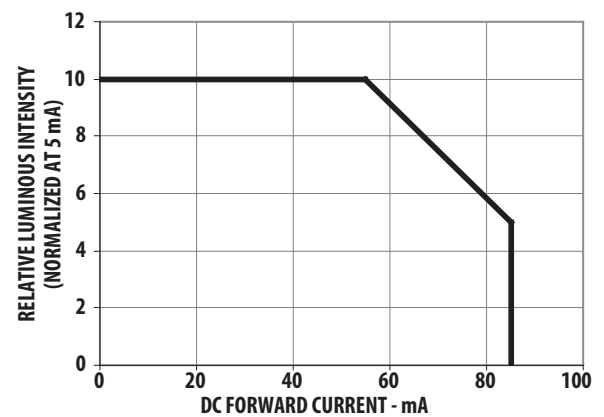

Figure 4. Maximum forward current vs. ambient temperature

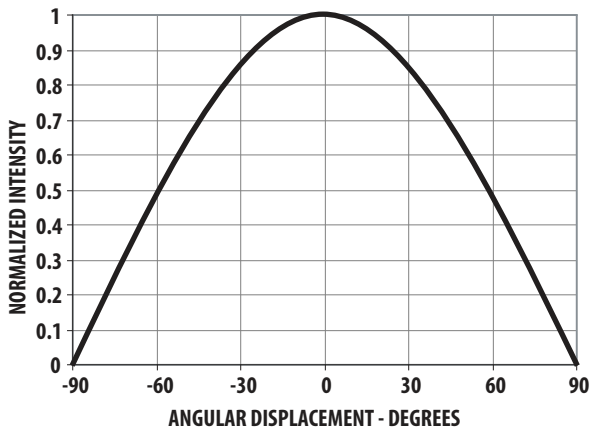
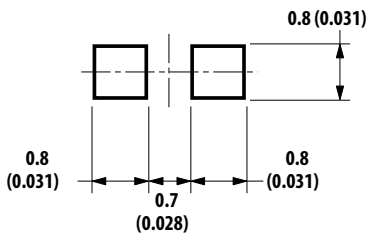

Figure 5. Radiation Pattern



Notes:

1. All dimensions are in millimeters (inches).
2. Tolerance is $\pm 0.1\text{mm}$ ($\pm 0.004\text{in.}$) unless otherwise specified.

Figure 6. Recommended soldering land pattern.

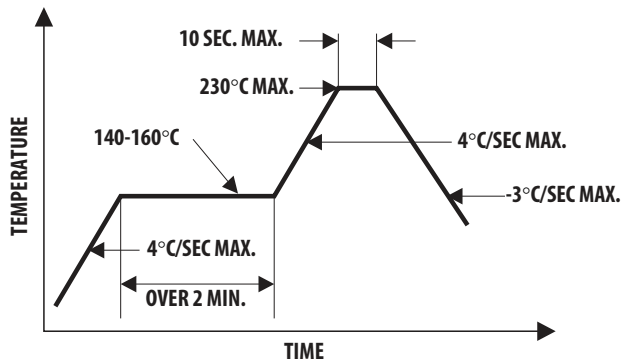

Figure 7. Recommended reflow soldering profile

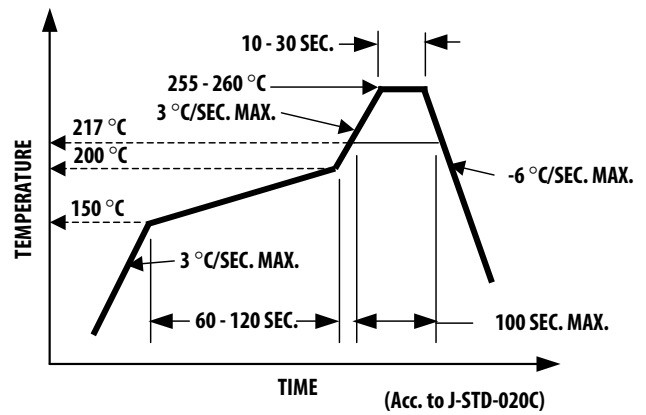

Figure 8. Recommended Pb-free reflow soldering profile.

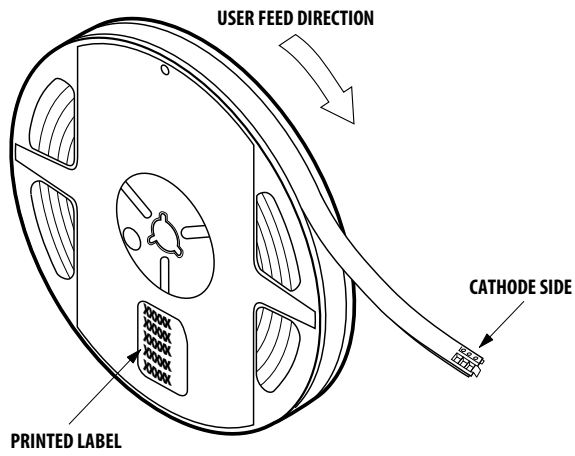
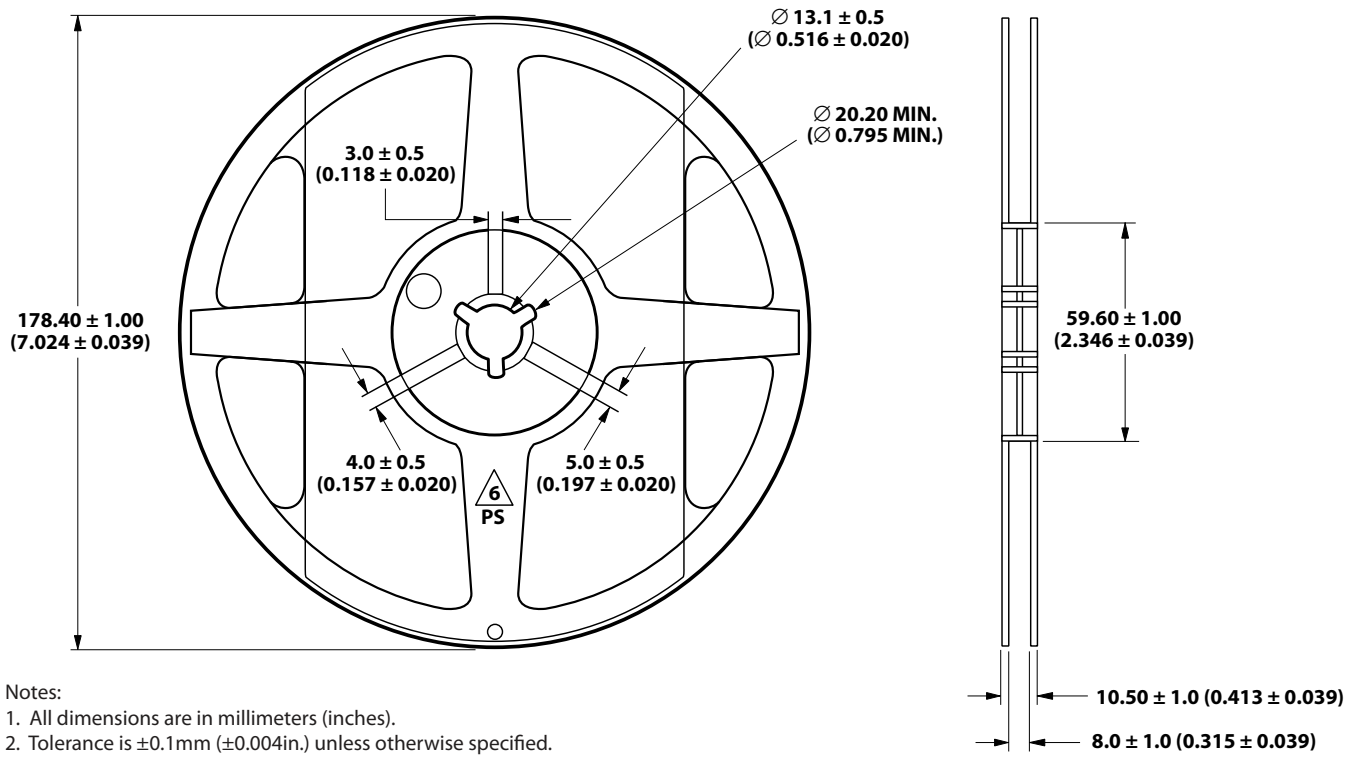

Figure 9. Reeling orientation.



- Notes:
1. All dimensions are in millimeters (inches).
 2. Tolerance is $\pm 0.1\text{mm}$ ($\pm 0.004\text{in.}$) unless otherwise specified.

Figure 10. Reel dimensions.

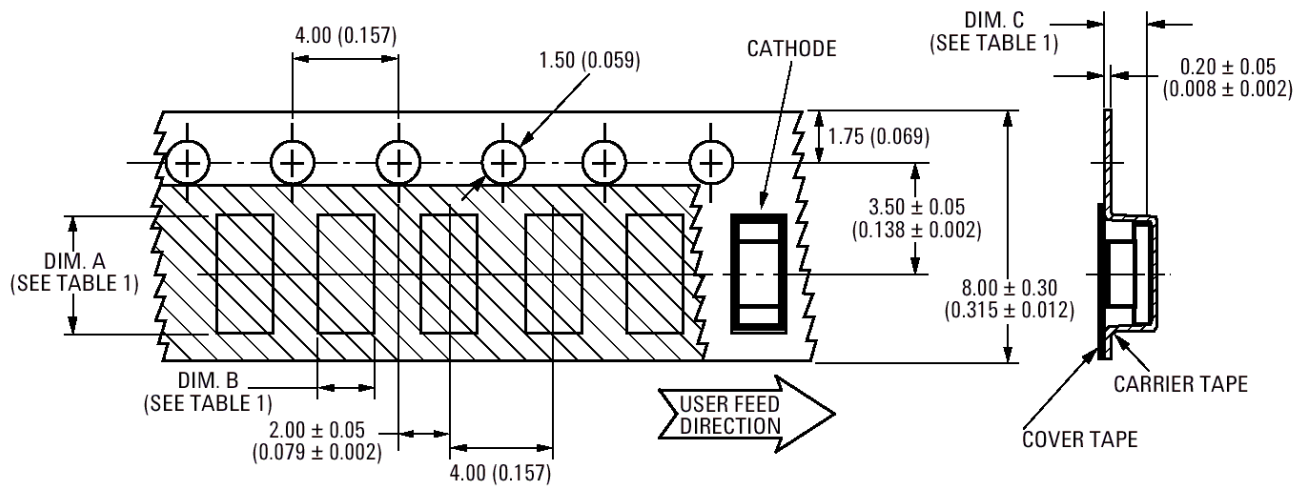

TABLE 1
DIMENSIONS IN MILLIMETERS (INCHES)

PART NUMBER	DIM. A	DIM. B	DIM. C
HSMR-CL25	1.75 (0.069) ± 0.10 (0.004)	0.88 (0.035) ± 0.10 (0.004)	0.40 (0.016) ± 0.10 (0.004)

Figure 11. Tape Dimensions

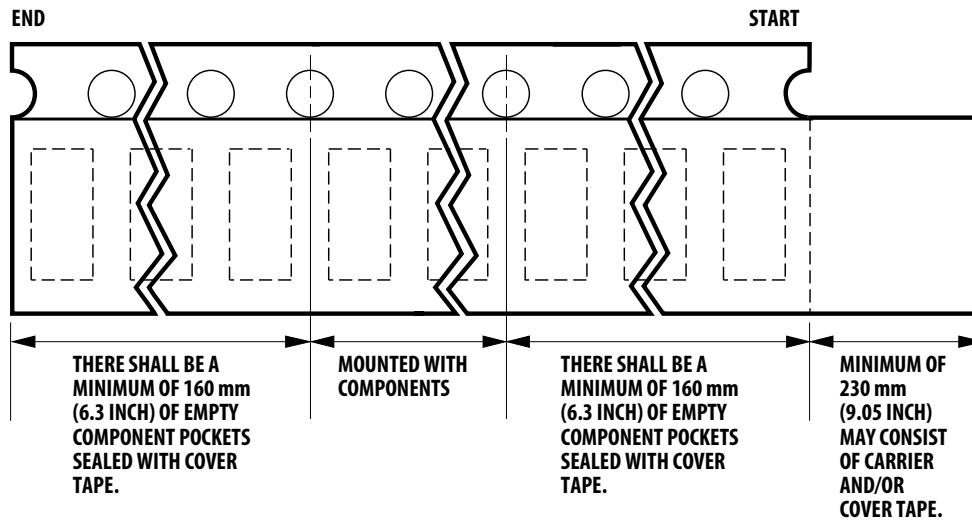

Figure 12. Tape leader and trailer dimensions.

Reflow Soldering:

For more information on reflow soldering, refer to Application Note AN-1060, Surface Mounting SMT LED Indicator Components.

Storage Condition:

5 to 30°C @ 60%RH max.

Baking is required before mounting, if:

1. Humidity Indicator Card is > 10% when read at $23 \pm 5^\circ\text{C}$.
2. Device expose to factory conditions <30°C/60%RH more than 168 hours.

Recommended baking condition:

$60 \pm 5^\circ\text{C}$ for 20 hours.

For product information and a complete list of distributors, please go to our web site: www.avagotech.com

Avago, Avago Technologies, and the A logo are trademarks of Avago Technologies in the United States and other countries. Data subject to change. Copyright © 2005-2009 Avago Technologies. All rights reserved.. Obsoletes AV01-0704EN
Av02-1920EN - May 13, 2009

