

## CUSTOMER DRAWING

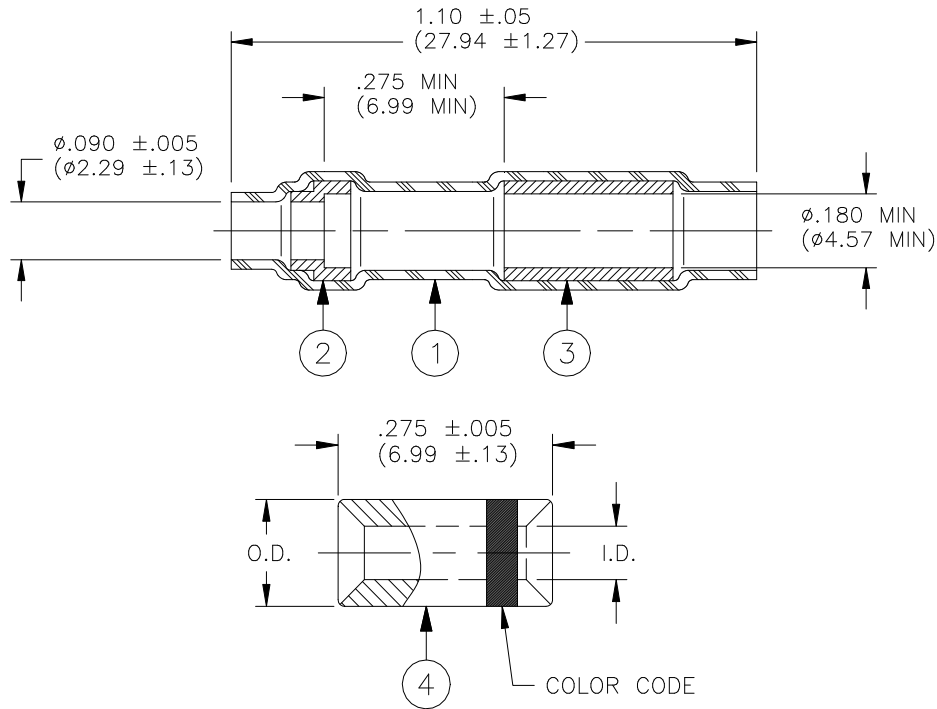

Dimensions Of Sub Splicer				I.D.		O.D.	
Product Name	Color Code	Max. Weight	CMA Range	min	max	min	max
D-436-58	Blue	1.4 lbs/Mpcs	1058-2680	1.63 (0.064)	1.75 (0.069)	2.57 (0.101)	2.69 (0.106)
D-436-59	Yellow	1.8 lbs/Mpcs	2375-6755	2.46 (0.097)	2.59 (0.102)	3.73 (0.147)	3.89 (0.153)

### MATERIAL

1. INSULATION SLEEVE: Heat-shrinkable, radiation cross-linked modified polyvinylidene fluoride. Transparent blue.
2. MELTABLE SEALING INSERT: Modified, immersion resistant thermoplastic. Color: natural.
3. MELTABLE SEALING INSERT: Modified, immersion resistant thermoplastic. Color: natural.
4. SEAMLESS STUB SPLICER:  
 BASE METAL: Copper alloy 101 or 102 per WW-T-775.  
 PLATING: Tin per MIL-T-10727, Type 1.

### APPLICATION

1. These parts are designed to provide an immersion resistant 2 wire stub splice, or a 2 to 1 parallel splice, made with having insulations rated for 135°C minimum.
2. Recovered dimensions of insulation sleeve (Item1):  
 I.D.: .095 (2.4130) Max.  
 Wall: .013 (0.3302) Min.
3. For installation procedures refer to Tyco Electronics/Raychem's "Miniseal D-436 Series Sealed Crimp Splice Products Installation Guidelines."

			<b>TITLE:</b> <b>STUB SPLICE SEALING SYSTEM</b>			
Unless otherwise specified dimensions are in millimeters. [Inches dimensions are shown in brackets]		<b>Raychem Devices</b>		<b>DOCUMENT NO.:</b> <b>D-436-58/-59</b>		
TOLERANCES: 0.00 N/A 0.0 N/A 0 N/A	ANGLES: N/A  ROUGHNESS IN MICRON	Tyco Electronics reserves the right to amend this drawing at any time. Users should evaluate the suitability of the product for their application.		REV:  J1	DATE:  June 14, 2018	
REVISED BY: UNGUYEN	CAGE CODE: 06090			ECO NUMBER: ECO-18-009289	SCALE:  NTS	SIZE:  A

© 2004-2018 TE Connectivity Corporation. All rights reserved.

If this document is printed it becomes uncontrolled. Check for the latest revision.