

THIS DRAWING IS UNPUBLISHED. RELEASED FOR PUBLICATION  
 © COPYRIGHT BY TYCO ELECTRONICS CORPORATION. ALL RIGHTS RESERVED.

LOC	DIST	REVISIONS			
P	LTR	DESCRIPTION	DATE	DWN	APVD
AJ	16	A	REV PER ECO 06-002539	07APR06	GB JH

1. USE INSTRUCTION SHEET 408-1799-5.
2. FOR USE WITH: RG-58/U, 58A/U, 58B/U, & 58C/U CABLE.
3. USE PROCRIMPER 354940-1 WITH DIE SET 91904-4.

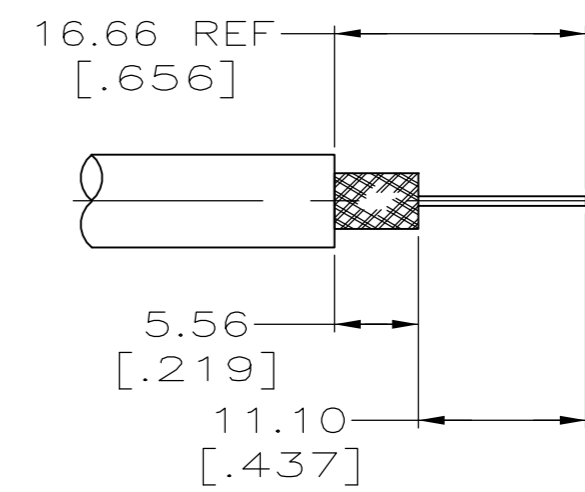
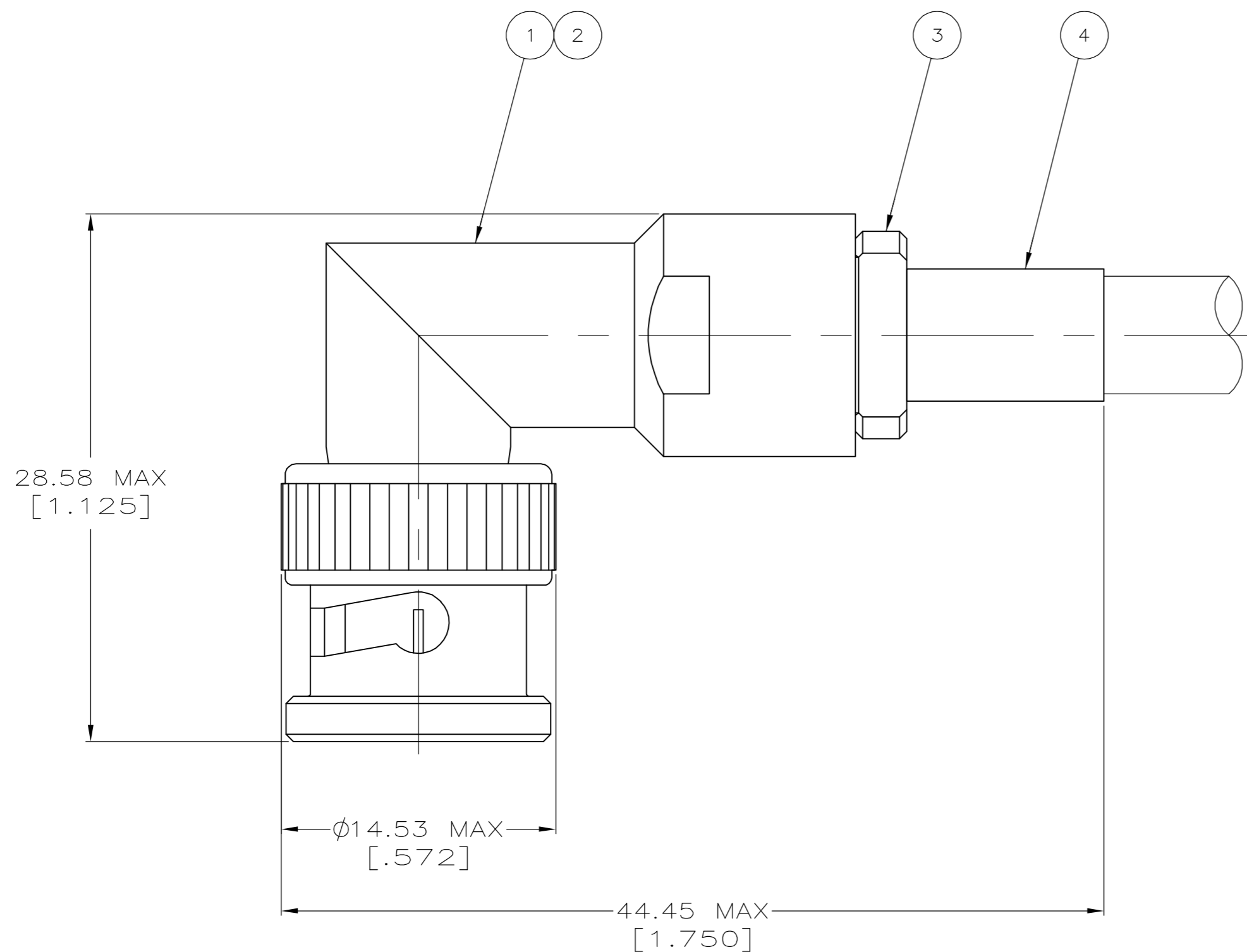

RECOMMENDED STRIP LENGTH  
SCALE 2:1

9-328663-0	9-50793-0	2-329106-1	9-330797-0	5331175
④ FERRULE QTY=1	③ CRIMP END ASSEMBLY QTY=1	② GASKET QTY=1	① PLUG ASSEMBLY, BULKHEAD QTY=1	PART NUMBER

THIS DRAWING IS A CONTROLLED DOCUMENT.

DWN	B. MCMASTER	20DEC05
CHK	J. LIPPERT	20DEC05
APVD	J. LIPPERT	20DEC05
PRODUCT SPEC	-	
APPLICATION SPEC	-	
WEIGHT	-	
CUSTOMER DRAWING	-	

TOLERANCES UNLESS OTHERWISE SPECIFIED:

0 PLC	± -
1 PLC	± -
2 PLC	± 0.41 [.016]
3 PLC	± -
4 PLC	± -
ANGLES	± -
FINISH	-

**tyco Electronics** Tyco Electronics Corporation  
Harrisburg, PA 17105-3608

PLUG, RIGHT ANGLE, 50 OHM, BNC

SIZE	A2	CAGE CODE	00779	DRAWING NO	C=5331175	RESTRICTED TO	-
SCALE	4:1	SHEET	1 of 1	REV	A		