

Features

- Eight (8) Outputs Rated at 60V, 200mA
- Open-Drain, Pull-Down Driver Configuration
- 6V to 60V Driver Supply Range
- 2.7V to 5.5V Logic Supply Range
- 3-Wire Serial Interface plus Chip Select
- Captures Serial & Parallel Input Data
- Outputs Can Be Paralleled
- 28-Lead QFN Package

Applications

- White Goods
- ATE
- Industrial Equipment

Description

The MX878 is an 8-channel, high voltage switch with 8-bit parallel or serial input control. The MX878 connects directly to a microprocessor through a standard 3-wire serial interface. The open-drain, pull-down output configuration can drive up to 60 volts at 200mA. Outputs can be paralleled for increased drive current up to a device total of 1000mA sink.

The MX878 is designed to operate over a temperature range of -40°C to +85°C, and is available in a 28-lead QFN Package.

Ordering Information

Part	Description
MX878R	QFN-28 in Tubes (73/Tube)
MX878RTR	QFN-28 Tape & Reel (2500/Reel)



Functional Block Diagram

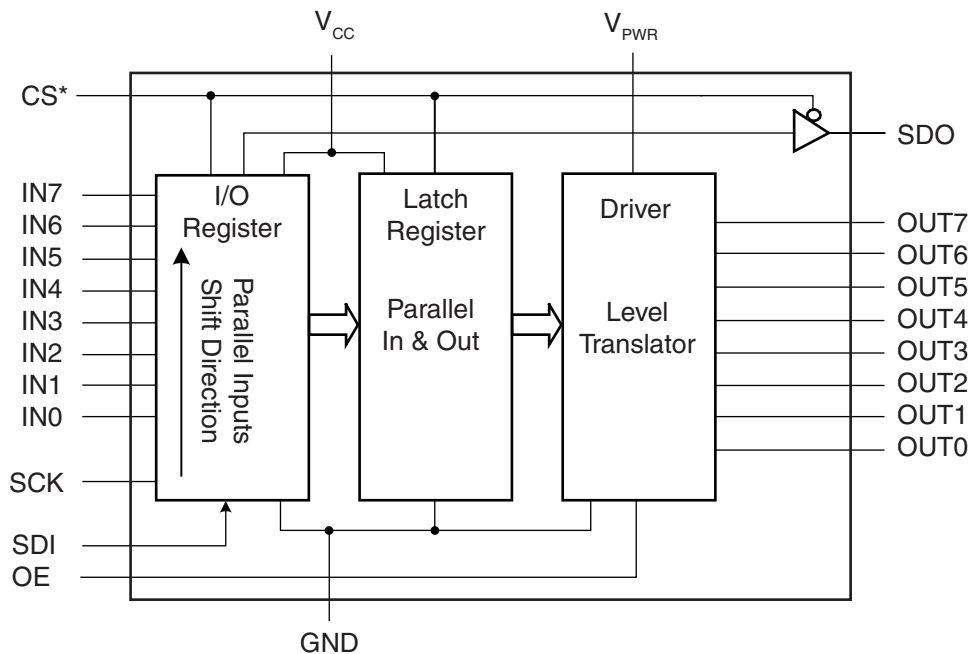

1. Specifications	3
1.1 Package Pinout	3
1.2 Pin Description	3
1.3 Absolute Maximum Ratings	4
1.4 DC Electrical Characteristics	4
1.5 Dynamic Electrical Characteristics	5
1.6 Serial Timing	6
1.7 Parallel Timing	6
2. Functional Description	7
3. Application Examples	8
3.1 Parallel In / Parallel Out Application	8
3.2 Serial Cascade Application	8
3.3 Control System Application	9
4. Manufacturing Information	10
4.1 Mechanical Dimensions	10
4.2 Soldering	11
4.3 Washing	11

1 Specifications

1.1 Package Pinout

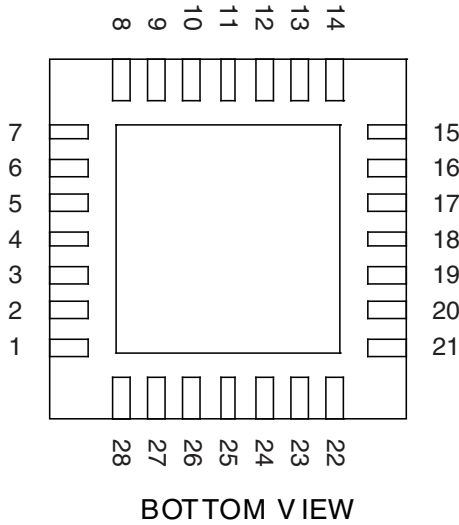

1.2 Pin Description

Pin#	Name	Description
1	OUT7	Parallel Output
2	N/C	No Connection
3	GND	Ground
4	V _{PWR}	High Voltage Supply (6V to 60V)
5	N/C	No Connection
6	V _{CC}	Logic Supply (2.7V to 5.5V)
7	SDO	Serial Data Output
8	IN7	Parallel Input
9	IN6	Parallel Input
10	IN5	Parallel Input
11	IN4	Parallel Input
12	IN3	Parallel Input
13	IN2	Parallel Input
14	IN1	Parallel Input
15	IN0	Parallel Input
16	SCK	Serial Clock
17	GND	Ground
18	SDI	Serial Data Input
19	CS*	Chip Select (Active Low)
20	OE	Output Enable
21	GND	Ground
22	OUT0	Parallel Output
23	OUT1	Parallel Output
24	OUT2	Parallel Output
25	OUT3	Parallel Output
26	OUT4	Parallel Output
27	OUT5	Parallel Output
28	OUT6	Parallel Output

1.3 Absolute Maximum Ratings

Parameter	Symbol	Min	Max	Units
VPWR Supply Voltage	V_{PWR}	-	60	V
Logic Supply Voltage	V_{CC}	-	6	V
Input Pin Voltage	V_{IN}	-	6	V
Continuous Output Current OUT0 - OUT7	I_{OUTn}	-	250	mA
Operating Junction Temperature	T_J	-	150	°C
Thermal Resistance (Junction to Ambient)	$R_{\theta JA}$	110 Typical		°C/W
Operating Temperature	T_A	-40	85	°C
Storage Temperature	T_{STG}	-55	150	°C

Absolute maximum electrical ratings are at 25°C

Absolute Maximum Ratings are stress ratings. Stresses in excess of these ratings can cause permanent damage to the device. Functional operation of the device at these or any other conditions beyond those indicated in the operational sections of this data sheet is not implied. Exposure of the device to the absolute maximum ratings for an extended period may degrade the device and affect its reliability.

Voltages with respect to GND=0V.

ESD Warning: ESD (electrostatic discharge) sensitive device. Although the MX878 features proprietary ESD protection circuitry, permanent damage may be sustained if subjected to high energy electrostatic discharges. Proper ESD precautions are recommended to avoid performance degradation or loss of functionality.

1.4 DC Electrical Characteristics

$V_{CC}=5V$, $V_{PWR}=42V$, $T_A=25^\circ C$, unless otherwise specified.

Parameter	Conditions	Symbol	Minimum	Typical	Maximum	Units
Logic Supply Voltage	-	V_{CC}	2.7	-	5.5	V
Logic Supply Current	$f_{SCK}=5MHz$	I_{CC}	-	50	-	μA
Quiescent Logic Supply Current	$f_{SCK}=0$	I_{CC}	-	-	1	μA
V_{PWR} Voltage	-	V_{PWR}	6	-	60	V
GND Current	Total of all Outputs	-	-	-	1000	mA
Quiescent VPWR Current	$V_{PWR}=42V$, No Load	I_{PWR}	-	0.75	-	mA
High Level Input Voltage	IN0-IN7, SCK, SDI, OE, CS*	V_{IH}	$V_{CC}-0.5$	-	-	V
Low Level Input Voltage	-	V_{IL}	-	-	0.5	V
Input Leakage Current	-	-	-	-	1	μA
SDO Tri-State Leakage Current	CS*=Logic High	-	-	-	1	μA
OUT0-OUT7 Current	Any One Output, Sink	-	-	-	200	mA
OUT0-OUT7 On-Resistance	$V_{PWR}=42V$	-	-	4.5	-	Ω
OUT0-7 Tri-State Leakage Current	OE=Logic Low	-	-	-	1	μA

Notes: To avoid unwanted output during V_{PWR} application and system initialization, keep OE at a logic low until CS* has completed one cycle.

Thermal Resistance is measured in still air with the device soldered to a 6 square inch board without a ground plane. Applications may require derating of the specified maximum currents to avoid exceeding the maximum operation junction temperature.

1.5 Dynamic Electrical Characteristics

$V_{CC}=5V$, $V_{PWR}=42V$, $T_A=25^\circ C$, unless otherwise specified.

Parameter	Conditions	Symbol	Minimum	Typical	Maximum	Units
SCK Period	-	-	100	-	DC	ns
SCK High Time	-	-	40	-	-	ns
SCK Low Time	-	-	40	-	-	ns
CS* High Time	-	tCSwh	50	-	-	ns
CS* Falling to SCK Rising	Setup Time	tCSs	150	-	-	ns
CS* Low Time	SCK Low (Parallel Input Mode)	tCSwl	150	-	-	ns
INx to CS Falling (SETUP TIME)	-	tINs	15	-	-	ns
INx to CS Falling (HOLD TIME)	-	tINh	30	-	-	ns
SDI to SCK Rising (SETUP TIME)	-	tSDIs	20	-	-	ns
SDI to SCK Rising (HOLD TIME)	-	tSDIh	25	-	-	ns
SCK Falling to SDO Data Valid	-	tSDO	-	10	-	ns
CS* Rising to SDO High Z	-	tSDOz	-	12	-	ns
CS* Rising to OUTx Falling	To 50%, C(OUTx)=1000pF	tOUTf	-	570	-	ns
OUTx Fall Time	From 10% to 90%, C(OUTx)=1000pF	-	-	75	-	ns
OE Rising to OUTx Rising	To 90%	-	-	580	-	ns
OE Rising to OUTx Falling	To 90%	-	-	390	-	ns
OE Falling to OUTx High Z	To 10%, OUTx High	-	-	130	-	ns
	To 10%, OUTx Low	-	-	90	-	ns

1.6 Serial Timing

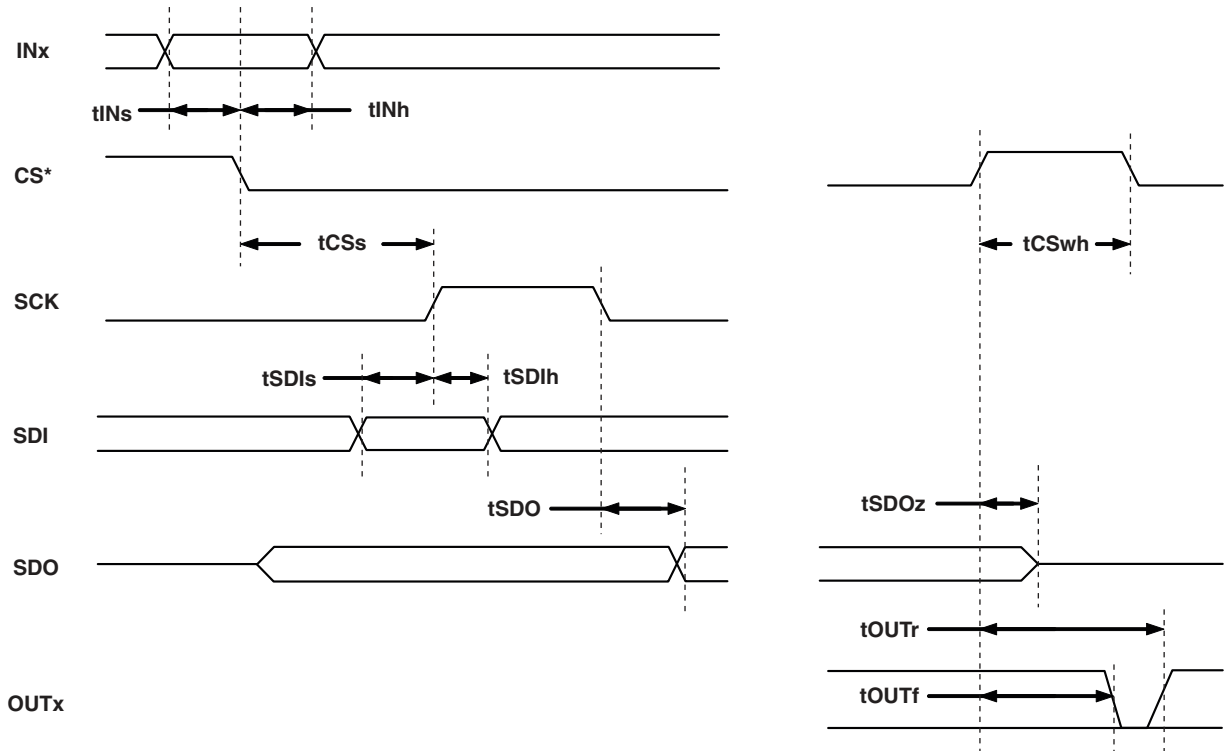

1.7 Parallel Timing

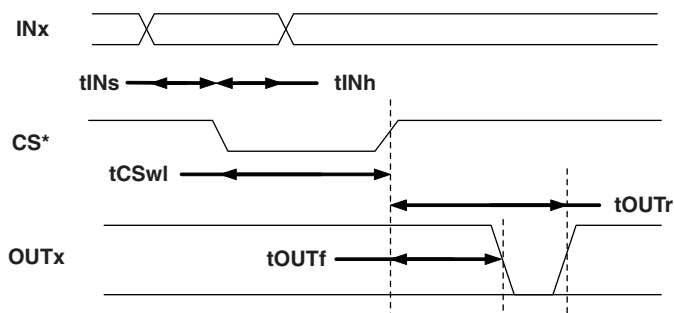

2 Functional Description

The MX878 is an 8-channel high-voltage driver with 8-bit input control. The MX878 interfaces to a microprocessor through a standard 3-wire serial interface and an active-low chip select, or can be used in a parallel-in, parallel-out configuration.

Parallel data is transferred to the I/O register of the MX878 through the parallel input pins, IN0 through IN7, on the falling edge of the chip select pin, CS*. When CS* is in a logic-low state, serial data can be transferred to the I/O register through the serial input pin, SDI, and from the I/O register through the serial output pin, SDO. Parallel or serial input data is transferred from the I/O register to the latch and high voltage output drivers, OUT0 through OUT7, on the positive edge of CS*. This data remains latched until the next positive edge of CS*.

The 8-bit I/O shift register is clocked by the serial clock pin, SCK. Serial data presented at the SDI pin is transferred to the shift register on the positive edge of SCK. Data shifts out of the register through the SDO pin on the negative edge of SCK. SDI and SCK are ignored, and SDO transitions to a high impedance condition when CS* is at a logic high state.

Serial data is received by the MX878 through the SDI pin. This data is accepted on the rising edge of SCK. A specific output is programmed to a logic-high state if SDI is at a logic-high state during the rising edge of SCK. Conversely, a specific output is programmed to a logic-low state if SDI is at a logic-low state during the rising edge of SCK. Outputs transition to their programmed states on the positive edge of CS* if the output enable pin, OE, is in a logic-high state.

The MSB input data (IN7) is presented at the serial output pin, SDO, on the falling edge of CS*. Input data from IN6 through IN0 is sequentially presented at SDO on negative SCK transitions if CS* remains in a logic-low state. If CS* is at a logic-low state beyond 8 cycles of SCK, SDI data that has propagated through the I/O register will then be presented at SDO. The SDO pin transitions to a high-impedance state when CS* is in a logic-high state, thus allowing multiple serial peripherals to share the microprocessor data pin.

Figure 1. Serial Data Transfer Example

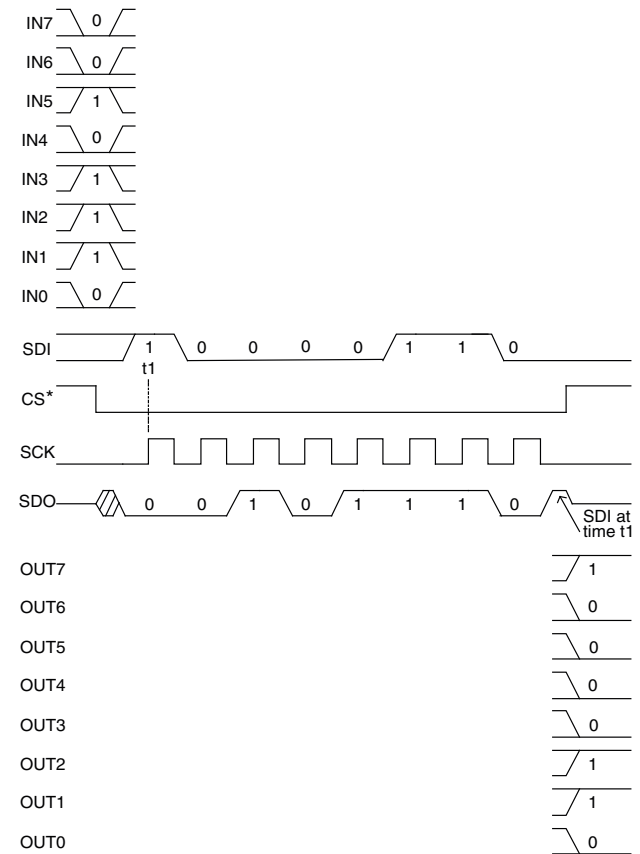

Devices may be serially cascaded by connecting SDO to SDI of the next device. Pins SCK and CS* are common to all devices in serial cascade. For n-cascaded devices the CS* should remain low for 8n cycles of SCK.

An output enable pin, OE, enables the driver outputs OUT0 through OUT7 when logic-high. A logic-low level on OE forces the OUT0 through OUT7 outputs to a high-impedance state.

The MX878 can also operate as a parallel-in, parallel-out level shifter and driver. SCK must remain at a logic-low state when operating in this mode. Parallel input data presented to IN0 through IN7 is captured on the falling edge of CS*. This data is transferred to OUT0 through OUT7 on the rising edge of CS*, and remains latched until the next rising edge of CS*.

3 Application Examples

3.1 Parallel In / Parallel Out Application

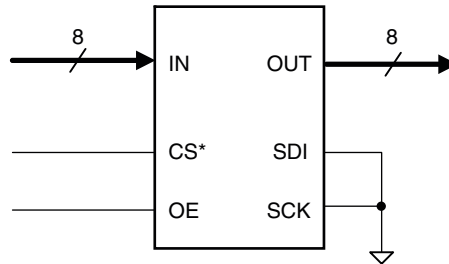

3.2 Serial Cascade Application

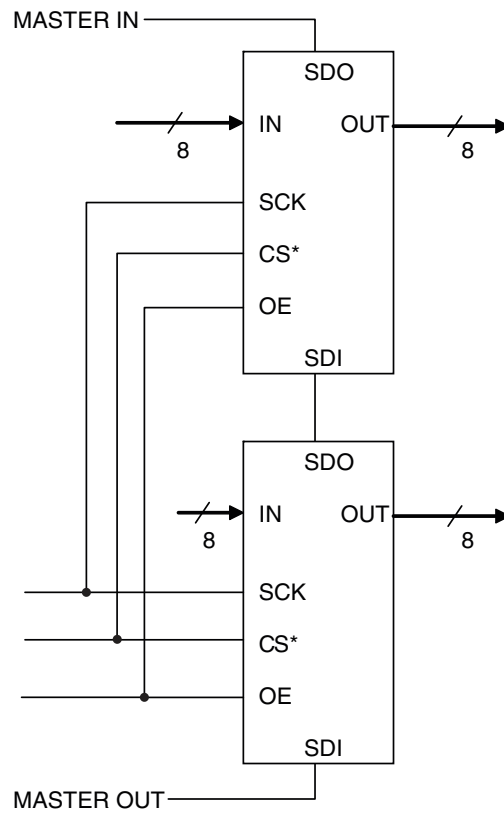

3.3 Control System Application

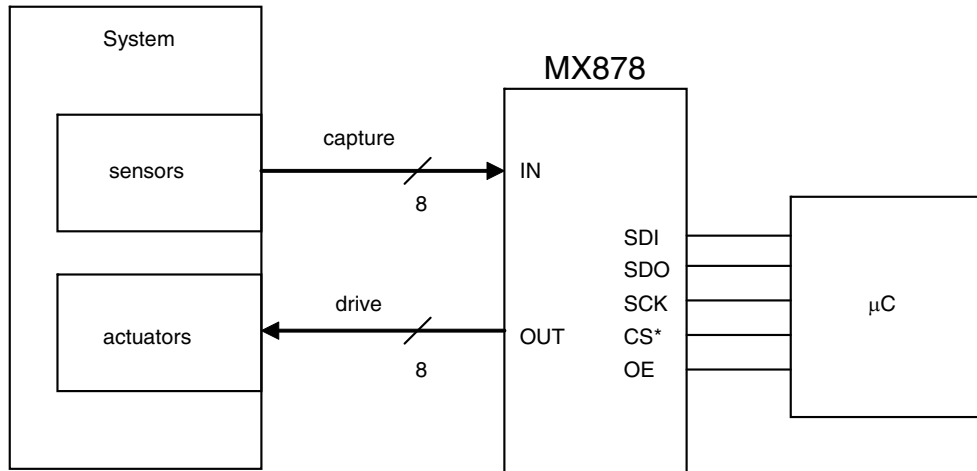

Type 1 timing:

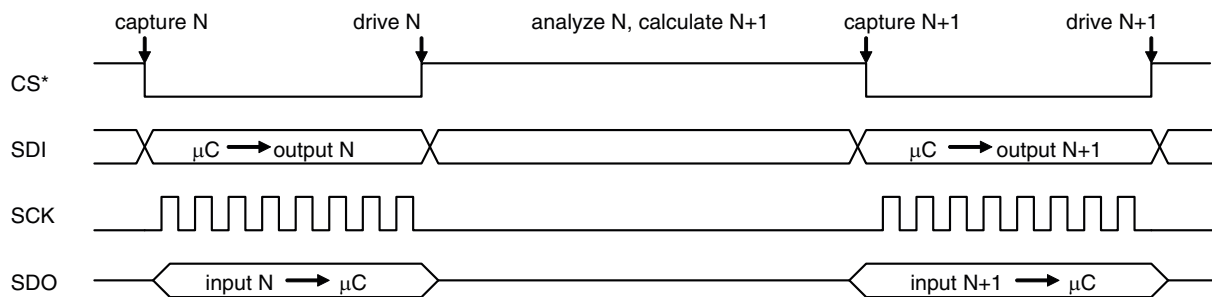

Type 2 timing:

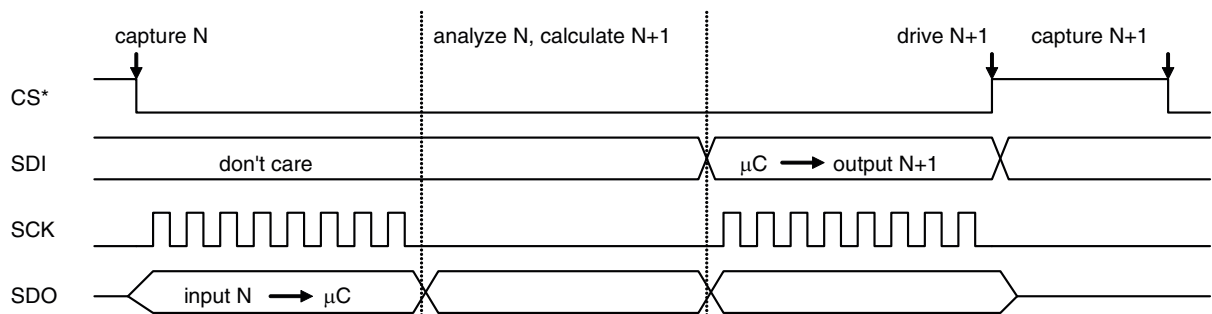

4 Manufacturing Information

4.1 Mechanical Dimensions

4.1.1 QFN-28 Package & Recommended PCB Land Pattern

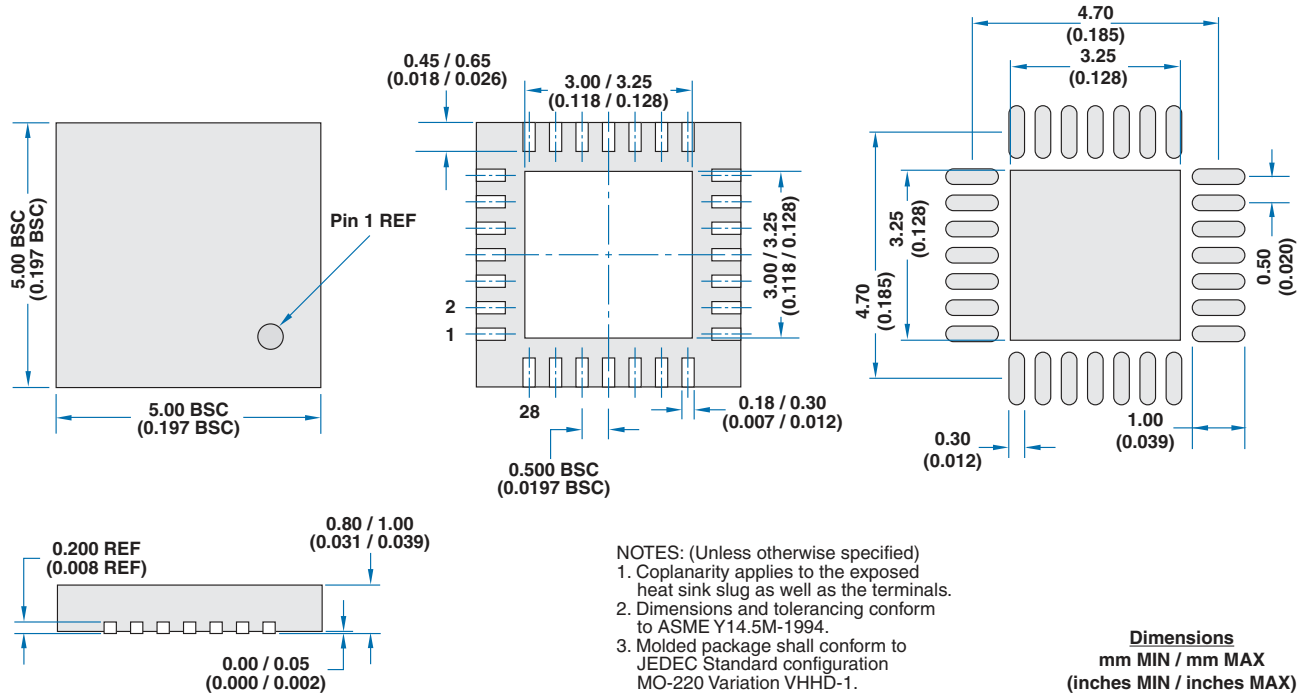

4.1.2 Tape & Reel

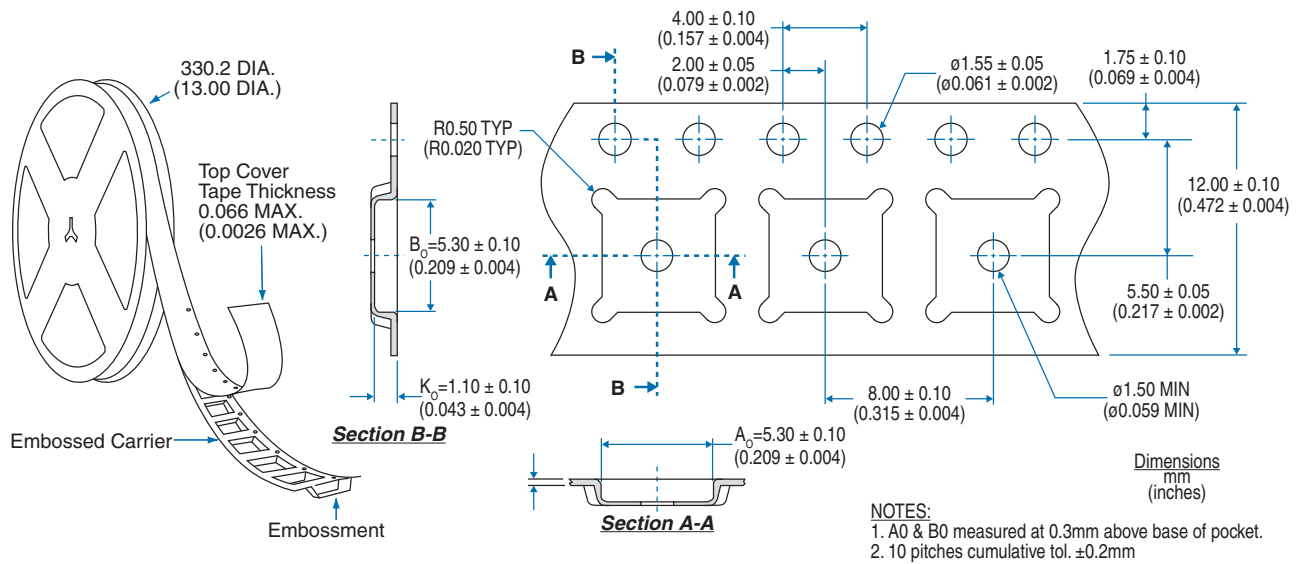

4.2 Soldering

For proper assembly, the component must be processed in accordance with the current revision of IPC/JEDEC standard J-STD-020. Failure to follow the recommended guidelines may cause permanent damage to the device resulting in impaired performance and/or a reduced lifetime expectancy.

4.3 Washing

Clare does not recommend ultrasonic cleaning or the use of chlorinated hydrocarbons.



For additional information please visit our website at: www.clare.com

Clare, Inc. makes no representations or warranties with respect to the accuracy or completeness of the contents of this publication and reserves the right to make changes to specifications and product descriptions at any time without notice. Neither circuit patent licenses nor indemnity are expressed or implied. Except as set forth in Clare's Standard Terms and Conditions of Sale, Clare, Inc. assumes no liability whatsoever, and disclaims any express or implied warranty, relating to its products including, but not limited to, the implied warranty of merchantability, fitness for a particular purpose, or infringement of any intellectual property right.

The products described in this document are not designed, intended, authorized or warranted for use as components in systems intended for surgical implant into the body, or in other applications intended to support or sustain life, or where malfunction of Clare's product may result in direct physical harm, injury, or death to a person or severe property or environmental damage. Clare, Inc. reserves the right to discontinue or make changes to its products at any time without notice.

Specification: DS-MX878-R00B
©Copyright 2009, Clare, Inc.
All rights reserved. Printed in USA.
12/17/09