

REVISIONS				
P	LTR	DESCRIPTION	DATE	APPV
A		REVISED PER ECO-15-016753	17NOV15	BJ FY

- ① HOUSING MATERIAL: GLASS-FILLED POLYMER.
- ② CONTACT MATERIAL: COPPER ALLOY.
- ③ CONTACT FINISH: DIN 41612 CLASS 2 IN CONTACT AREA. TIN PLATE ON POSTS.
- ④ PART NUMBER, DATE CODE IDENTIFICATION, CSA LOGO IN THIS APPROXIMATE AREA, ON REVERSE SIDE.
- ⑤ CONTACT POINT.
- ⑥ RECOMMENDED HOLE SIZE FOR MANUAL APPLICATION OF CONNECTOR ONTO PC BOARD.
- ⑦ PACKAGED BY TUBE

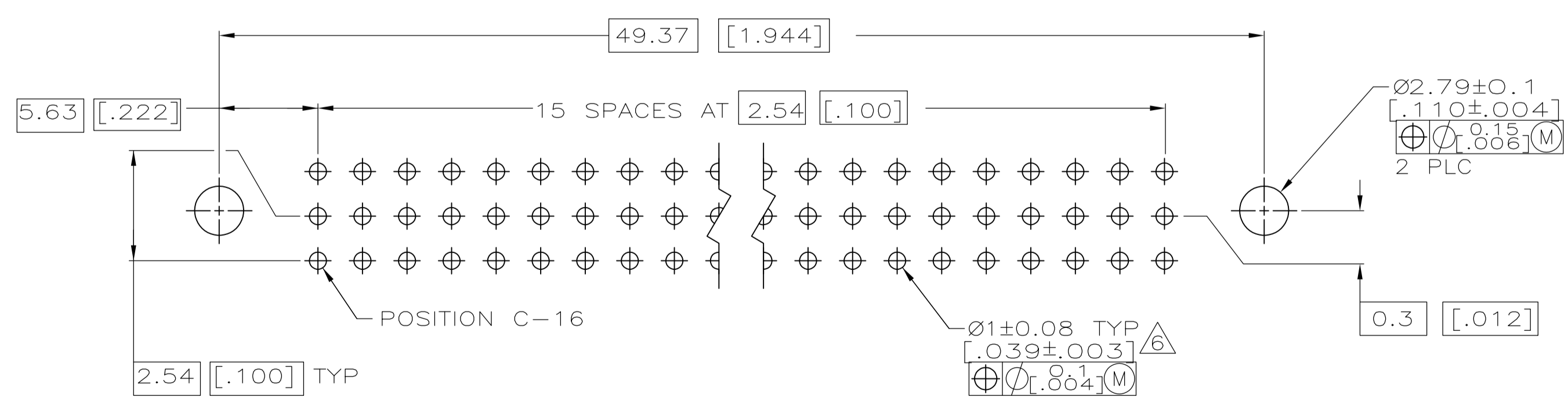
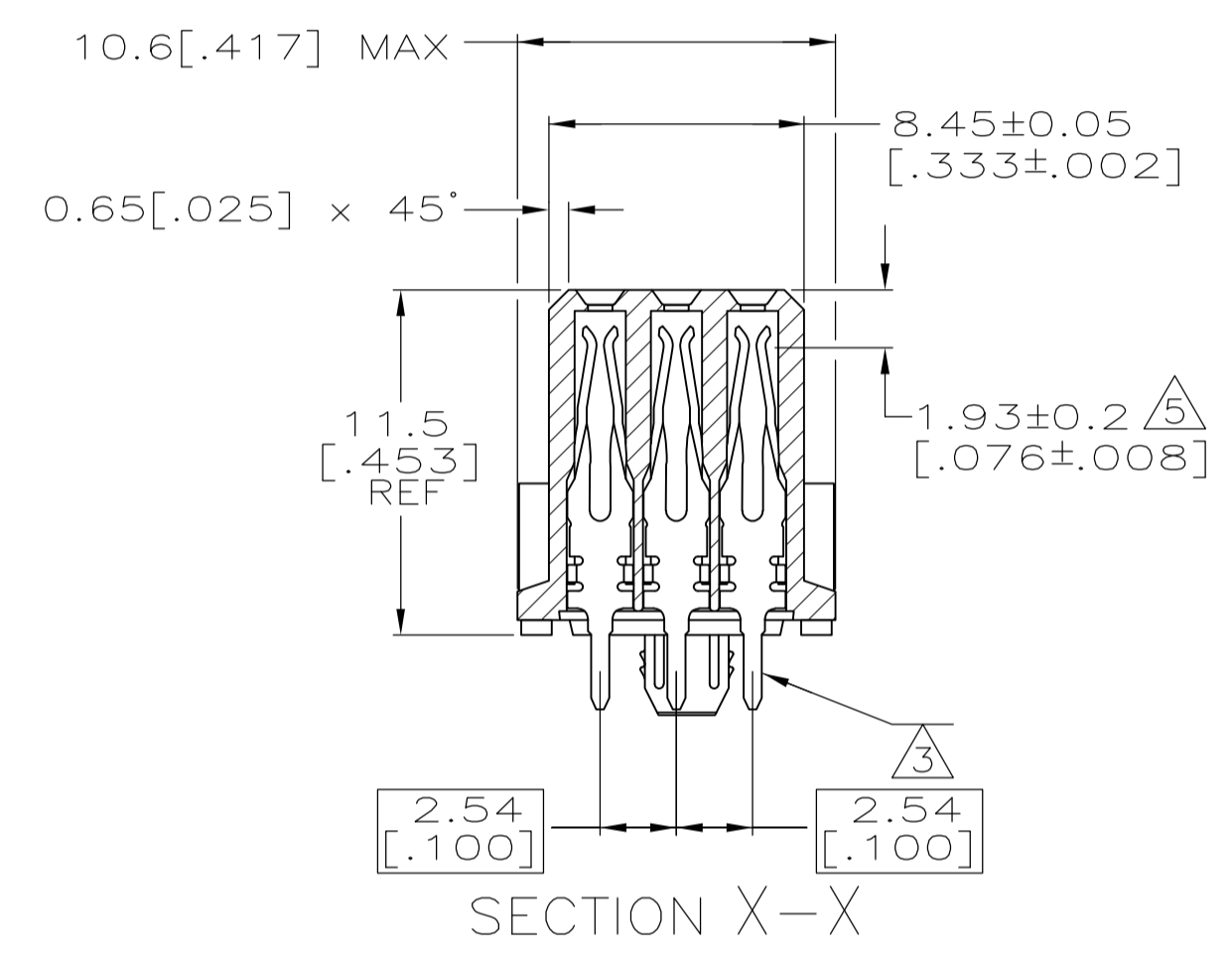
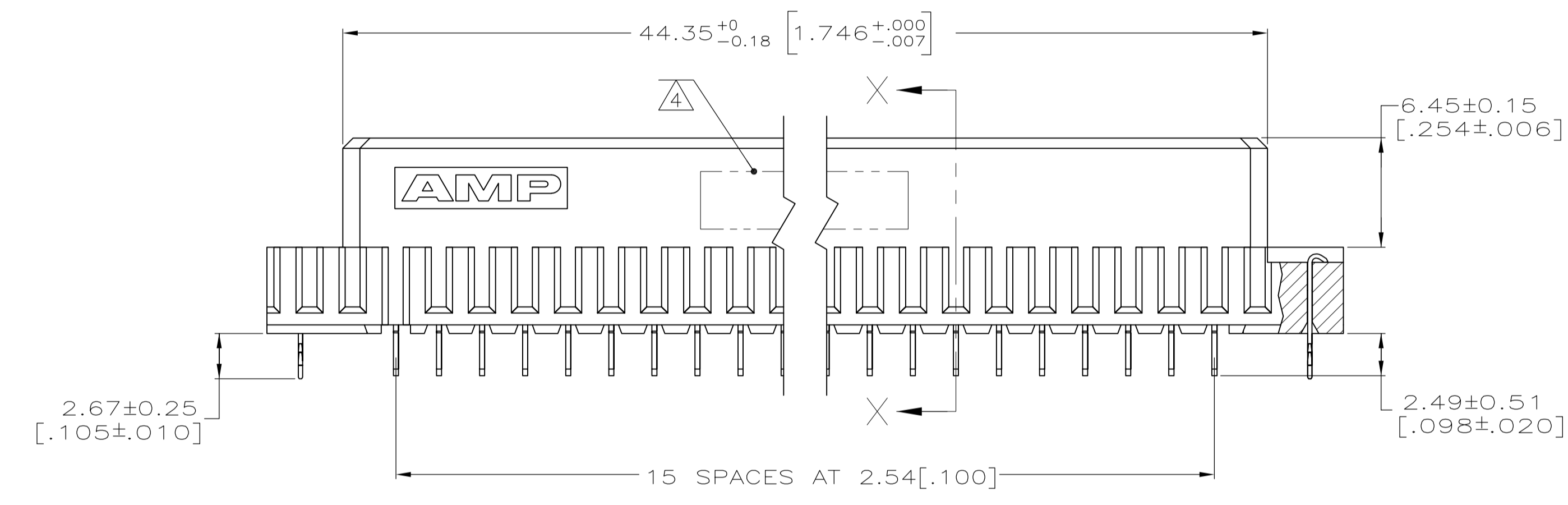
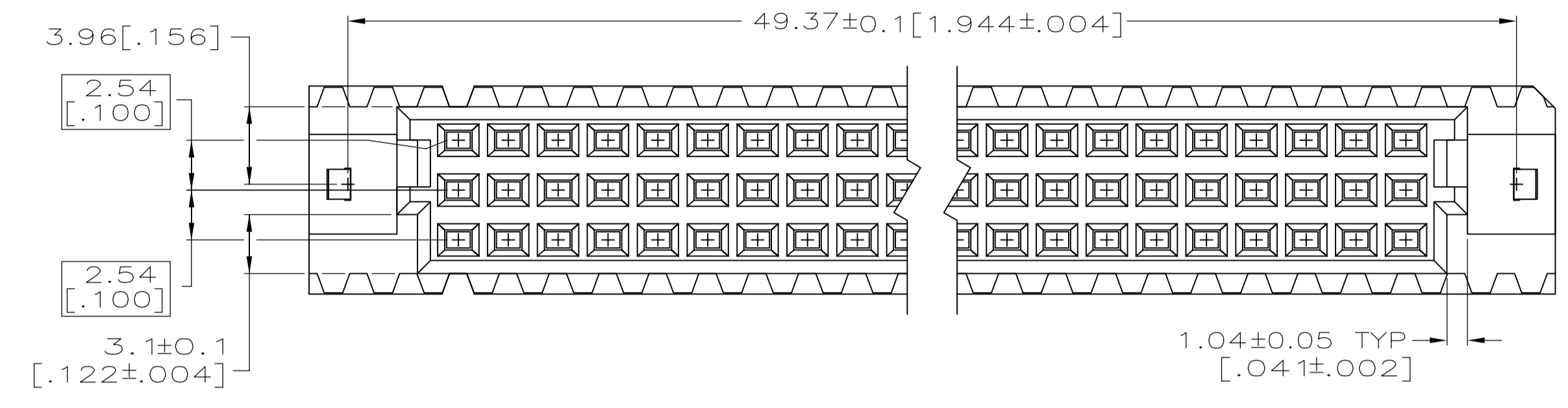

PC BOARD LAYOUT

⑦ 1-5536397-5  
5536397-5  
PART NUMBER

THIS DRAWING IS A CONTROLLED DOCUMENT.		DIN J. POLIGNONE 27MAY05	TE Connectivity
DIMENSIONS: mm [INCHES]		CIK A. SHARPE 27MAY05	
TOLERANCES UNLESS OTHERWISE SPECIFIED:		APVD A. SHARPE 27MAY05	NAME ASSEMBLY, RECEPTACLE, EUROCARD, TYPE 1/2C, LEAD-FREE, 48 POSITION, 2.49 [.098] SOLDER POSTS WITH BOARD-LOCKS
0 PLC ± -	1 PLC ± -	APPLICATION SPEC	SIZE CAGE CODE DRAWING NO
2 PLC ± -	3 PLC ± 0.13 [.005]	WEIGHT	A1 00779 C=5536397
4 PLC ± -	ANGLES ± -	CUSTOMER DRAWING	SCALE 4:1 SHEET 1 OF 1 REV A