

REV.	DATE	ECR NO.	DESCRIPTION
NC	08/12/10	XXXXXX	INITIAL RELEASE

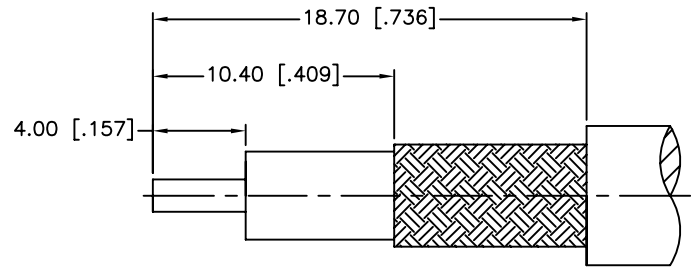

RECOMMENDED  
CABLE STRIPPING DIM'S

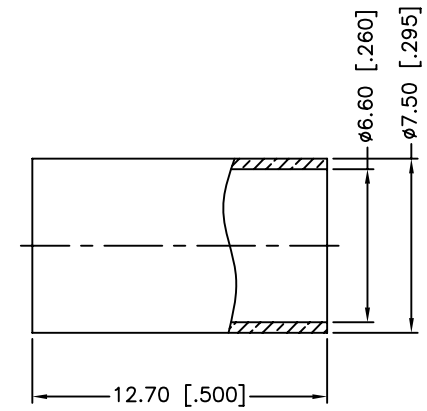
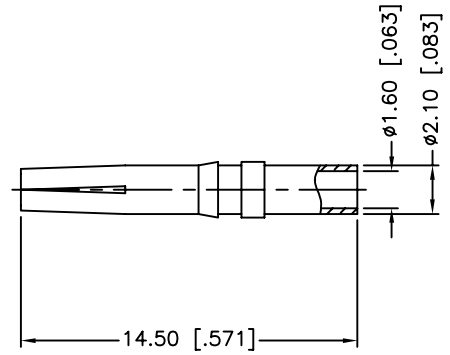
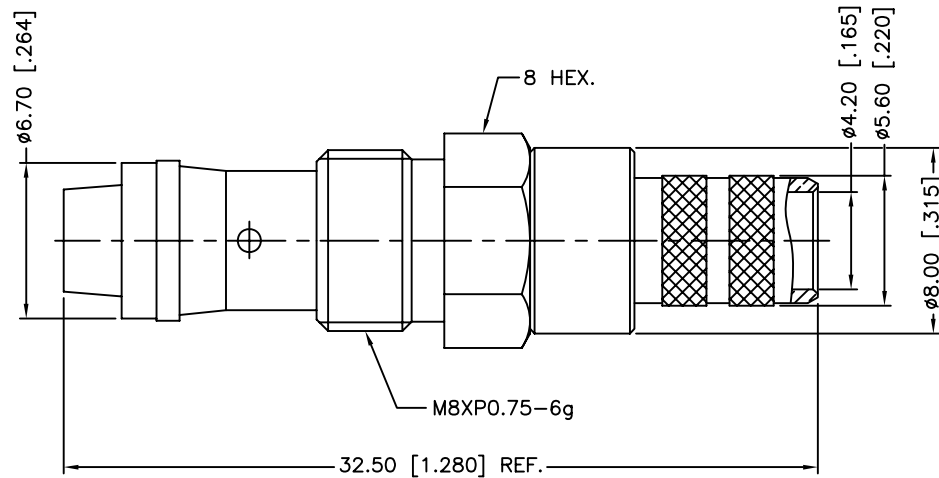

1. CRIMPED FERRULE  
HEX CRIMP SIZE .255"
2. CRIMPED CONTACT PIN  
HEX CRIMP SIZE .068"

6	FERRULE	BRASS	NICKEL	1
5	CONTACT PIN	PHOSPHOR BRONZE	GOLD	1
4	BARREL	BRASS	NICKEL	1
3	HEX NUT	BRASS	NICKEL	1
2	INSULATOR	PTFE	NATURAL	1
1	BODY	BRASS	NICKEL	1
DESCRIPTION	MATERIAL	FINISH	QTY	

UNLESS OTHERWISE SPECIFIED DIMENSIONS ARE IN MILLIMETERS. DIMENSIONS IN [ ] ARE IN INCHES AND FOR CUSTOMER REFERENCE ONLY.

UNLESS OTHERWISE SPECIFIED TOLERANCES FOR MILLIMETERS ARE:  
0.5 - 8mm ± 0.20mm  
8 - 30mm ± 0.40mm  
30 - 120mm ± 0.50mm

UNLESS OTHERWISE SPECIFIED TOLERANCES FOR INCHES ARE:  
.020 - .315 = ± 0.007"  
.315 - 1.180 = ± 0.015"  
1.180 - 4.724 = ± 0.020"

DO NOT SCALE DRAWING

APPROVALS	DATE
DRAWN M.ZHANG	08/12/10
CHECKED	
ISSUED	
SHEET 1 OF 1	
CAD FILE	C:/CONNEX/192116.DWG

**Amphenol Connex**

PART DESCRIPTION  
**FME ROTATING NIPPLE CRIMP JACK  
(FOR TIMES LMR-240, RG-8X CABLE)**

PART NO. **192116**

DWG. NO. 192116.DWG	REV. NC	SIZE A	SCALE NA
---------------------	---------	--------	----------