

## Introduction

The AMD Hammer family microprocessors feature higher clock speeds and greater device density than previous product families. The power management solution for this next generation family of microprocessors must contend with lower core voltages, tighter transient specifications, and higher peak current demands. Responding to the changing power management needs of its customers, Intersil introduces the ISL6559 controller to power the AMD Hammer family microprocessors.

## Intersil ISL6559 and ISL6605

The ISL6559EVAL1 is a versatile voltage regulator-module (VRM) design. The evaluation board comes configured for 4-phase multi-phase buck operation, designed to meet AMD Hammer Family Desktop Processor specifications. The board can easily be modified to support evaluation at lower current specifications. The ISL6559 controller functions are specifically designed to compliment and support the Hammer Family feature set with ISL6605 drivers. The chipset forms a highly integrated solution for AMD Hammer processor applications.

The ISL6559 regulates output voltage and balances load currents for two to four synchronous buck converter channels. The controller features a 5-bit DAC, which provides a digital interface for accurate voltage programming over the entire Hammer Family range of 0.800V to 1.550V. New multi-phase family features include differential remote output voltage sensing, to improve regulation tolerance; pin-adjustable reference offset, for ease of implementation; VID-on-the-Fly, to respond to DAC changes during operation; and optional load line regulation. For a more detailed description of the ISL6559 functionality, refer to the data sheet [1].

The ISL6605 driver is chosen to drive two N-Channel power MOSFETs in a synchronous-rectified buck converter channel. Each channel has a single logic input that controls the upper and lower MOSFETs. Dead time is optimized on both switching edges to provide shoot-thru protection. Internal bootstrap circuitry only requires an external capacitor and provides better enhancement of the upper MOSFET. For a more detailed description of the ISL6605, refer to the data sheet [2].

The Intersil multi-phase family controller and driver portfolio continues to expand with new selections to better fit our customer's needs. Refer to our website for updated information, [www.intersil.com](http://www.intersil.com).

## ISL6559 VRM Reference Design

The evaluation kit consists of the ISL6559EVAL1 board, associated data sheets on the ISL6559 controller and ISL6605 driver, as well as this application note. The evaluation kit also includes the Elcon VRM test board which has an edged connector for the VRM to plug into. The evaluation kit provides convenient test points, a banana jack for power supply connectors, and an on-board transient load generator to facilitate the evaluation process. The ISL6559EVAL1 board and test board is configured to run off of a single 12V supply.

**TABLE 1. 4-PHASE VRM DESIGN PARAMETERS**

PARAMETER	MIN	MAX
Static Regulation	1.109V	1.250V
Transient Regulation	1.109V	1.250V
Continuous Load Current	3A	100A
Load Current Step		100A
Load Current Transient		~560A/ $\mu$ s

The evaluation board meets the output voltage and current specifications, shown in Table 1, with the VID DIP switch (set to 01100 (1.250V)). The 1U VRM board is fabricated using 6 layers with 3oz copper on outer and 4oz copper on inner layers. The test board is implemented in 4-layer, 2oz copper. Layout plots and part lists are provided at the end of the application note for this design.

## Quick Start Evaluation

### Circuit Setup

The ISL6559EVAL1 board will arrive with the VID DIP switch (U2) set to 01100 (1.250V). If another output voltage level is desired, refer to the ISL6559 data sheet for the complete DAC table and change the VID switches accordingly. Note that changing the U2 VID states will change the dynamics of the load generator.

### Input Power Connections

A single power supply connection is provided on the VRM test board. Insure connection is secure.

Two female banana jacks are provided for connection of the bench top power supply. Connect the +12V terminal to J5, and the common ground to terminal J6.

**Power Output Connections**

The ISL6559EVAL1 output can be exercised using either resistive or electronic loads. Copper alloy terminal lugs provide connection points for loading. Tie the positive load connection to V<sub>CORE</sub>, terminal J2 or J3, and the negative to ground, terminal J4 and J10. A shielded scope probe test point, J8, allows for inspection of the output voltage, V<sub>CORE</sub>.

**Enabling the Controller**

The state of V<sub>CC</sub>, EN, and FS/DIS dictate the beginning of a soft-start interval. The FS/DIS pin is used to set the per phase switching frequency on the evaluation board. Once the input and output terminal connections are made, remove the shunt across the jumper (J11) pins 3, 4 labeled OUT\_EN if installed. The EN signal is released to rise above the ENABLE threshold of 1.23V nominal. Once the ENABLE threshold is exceeded, a soft-start interval is initiated. The output voltage will ramp in a controlled manner.

A resistor divider from the +12V input is connected to EN on the controller and the drivers to insure that the drivers and controller come up at the same time.

**On-Board Load Transient Generator**

Most bench-top electronic loads are not capable of producing the current slew rates required to emulate modern microprocessors. For this reason, a discrete transient load generator is provided on the VRM test board for evaluation.

The VRM test board is designed to work in conjunction with the ISL6559 eval board. The VRM test board schematic is located in later pages of this application note. In addition to the transient load generator, the board consists of a card edge connector (J1), pull up resistors for the VID pins, and scope probes as well as turrets for monitoring the input and output voltage. This board comes configured with an all ceramic output filter, but you have the option to add Oscon or larger ceramic capacitors.

The on board transient circuit can be modified to operate at different frequencies or have different load steps. As received the on-board transient is designed to operate at 33Hz. The current step is dependent on the di/dt of the transient load which is dependent on the output voltage and the number of switches being used as seen in Figure 1.

Where: (EQ. 1)

- $di/dt = V_{out} \times N / (t_{rise} \times R_{EQ})$
- di/dt is the transient slew rate
- N is the number of switches
- $t_{rise}$  is the rise time
- $R_{EQ}$  is the equivalent resistance
- $V_{OUT}$  is the output voltage

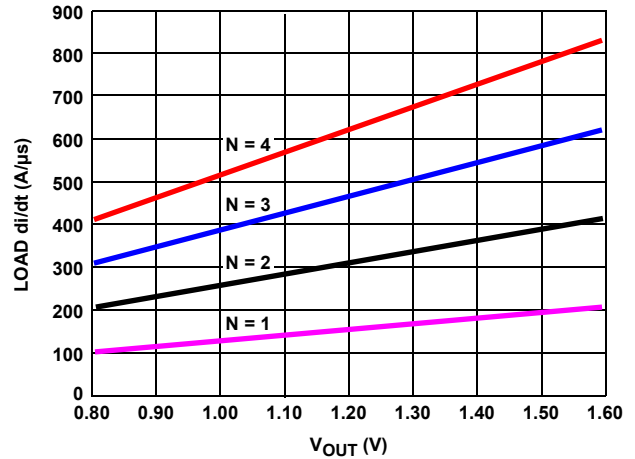

FIGURE 1. PLOT OF TRANSIENT LOAD CIRCUIT

The load step can be verified by measuring the voltage at J7 of the test board. Once you have that value you can calculate your current step. The di/dt can be verified by measuring the rise time of the load step. Rise time is measured from 10% and 90% of the transient voltage. Plug that value into equation 1 to calculate the di/dt. The rise time can be improved by switching to thin film resistors from the wire wound resistors.

The low frequency transient is running at 33Hz but can be modified to run faster by simply adjusting the values of R6, R7 and C80. Frequency can be increased by decreasing the value of C80 (currently 10µF). If you want to change the duty cycle, ON time is proportional to R7 (402Ω) and the OFF time is proportional to R6 (46.7kΩ). It may be necessary to decrease the ON time at high frequency. If the duty cycle is too high, the switching transistor and sense resistors will overheat. Do not use less than 10Ω for R7 or the max pulsed current in Q1 will exceed its rating.

The load resistor values are 120mΩ stacked 3 high that gives effectively 40mΩ, the r<sub>DS(ON)</sub> of the FETs is 16mΩ. Thus, the equivalent resistance for each switch is 56mΩ.

## ISL6559 VRM Performance

### Soft-Start Interval

The typical start-up waveforms for the ISL6559EVAL1 are shown in Figure 2. The DAC is set to 01100 (1.250V) and the converter is started into a 100A load. The OUT\_EN jumper is removed and the voltage on EN quickly rises above the ISL6559 enable threshold, triggering a soft-start interval. The switching frequency of the converter is 600kHz, therefore the soft-start interval (SS Interval) is approximately 3.4ms per the datasheet. On this evaluation board the 5V linear supply that is used to power up the controller is disabled when the enable pin is tied low. This causes the PGOOD pin to float high until VCC rises above the POR threshold of the controller and pulls the PGOOD pin low.

The output undervoltage threshold is defined as the DAC setting minus 350mV. Once this threshold is surpassed, the internal pull down on the PGOOD pin is released.

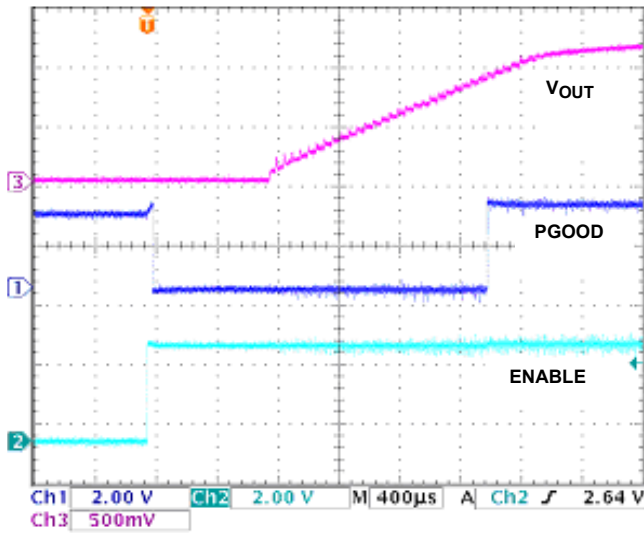

FIGURE 2. SOFT-START INTERVAL WAVEFORMS

### Transient Response

The transient slew rate is designed for a nominal 560A/µs, but can be adjusted as described previously. During a transient, the core voltage is required to remain within the static window of ±50mV around the DAC setting. The on-board load generator and a bench-top electronic load simulate these conditions.

The OFS pin allows the user to positively offset the DAC reference voltage by placing a correctly sized resistor from this pin to ground, R14. For this design, the resistor value is 0Ω, which equates to no offset at no-load. Load-line regulation is supported by the ISL6559. The average current of the four active channels flows out I<sub>OUT</sub>. When this pin is connected to FB, this average current creates a voltage drop across R9. This voltage drop is proportional to the output

current of the converter and effectively creates an output voltage droop; the output impedance is 0.91mΩ.

The rising edge transient response of the ISL6559EVAL1 to the aforementioned maximum load conditions is shown in Figure 3. A bench-top electronic load draws 0A continuously from the converter, while the on-board load generator provides a ~100A load step. This design incorporates an all ceramic output filter which reduces the effective ESR/ESL resulting in an excellent transient response with a measured bandwidth of 140kHz.

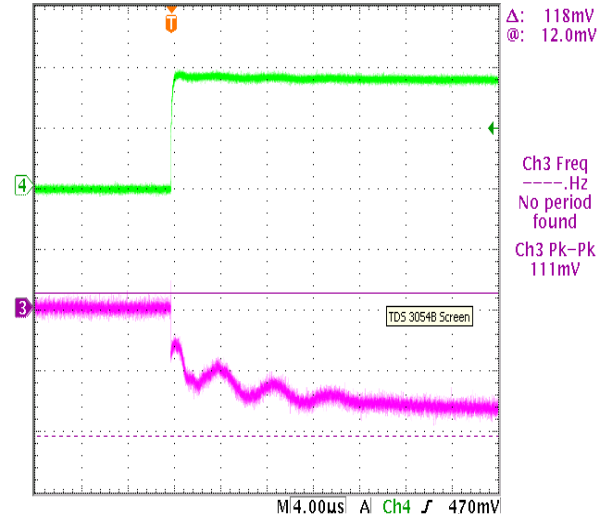

FIGURE 3. RISING EDGE TRANSIENT RESPONSE

Figure 4 shows the load release response of the converter. There is no overshoot due to the low ESR and ESL of the all ceramic output capacitor bank and small output inductors (100nH) employed in this design.

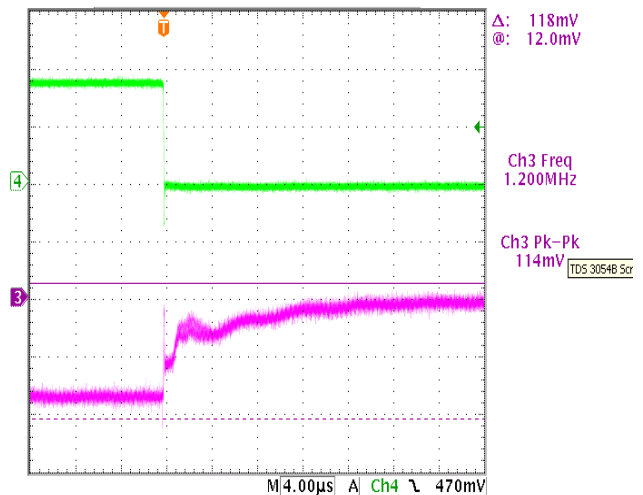

FIGURE 4. FALLING EDGE TRANSIENT RESPONSE

**Overcurrent Protection**

The ISL6559 monitors the output current level by averaging the sampled current from each ISEN pin. The  $R_{ISEN}$  resistors (R1, R2, R3, R4) are selected such that the current sourced by the ISEN pins is  $50\mu A$  at maximum load current. The average of the sampled currents is compared with an overcurrent trip level of  $90\mu A$ . Once the average current meets or exceeds the OC reference current, the controller immediately places all PWM signals in a high-impedance state, quickly removing gate drive to the ISL6605 drivers. This forces the core voltage to decay as the output capacitors discharge. The PGOOD signal transitions low when the core voltage drops below the UV threshold.

After the overcurrent event is detected, the controller waits a short delay time before initiating a soft-start interval to allow the disturbance to clear. The delay time is equivalent to the soft-start interval and for this design is 3.4ms. If during the soft-start interval another overcurrent trip is detected, the PWM signals are again placed in a high impedance state and PGOOD remains low. The controller waits another 3.4ms before another soft-start interval is attempted. This hiccup mode of operation repeats up to six times, with a seventh successive event causing the converter to latch off.

Figure 5 shows the hiccup mode operation of the converter when a hard short is applied across the output terminals of the evaluation board. The converter quickly places the PWM signals in a high-impedance state and the core voltage decays quickly. The short is not removed, resulting in the controller latching off after the seventh attempt. The hiccup mode is explained more thoroughly in the datasheet.

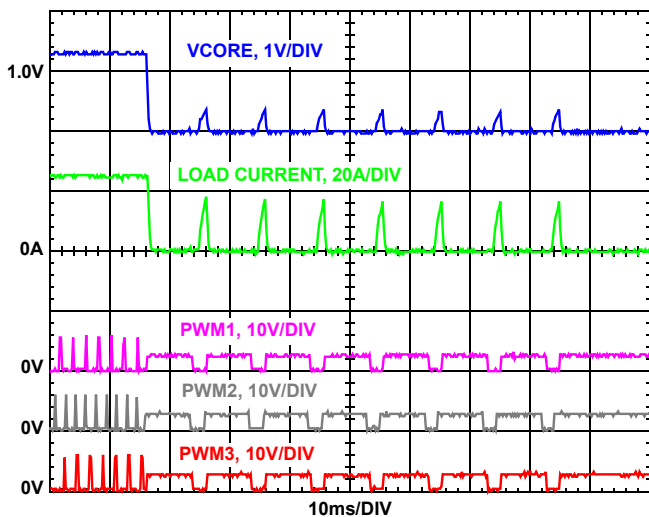

FIGURE 5. OVERCURRENT PROTECTION

**VID on the Fly**

The AMD Hammer Family microprocessors can change VID inputs at any time while the regulator is in operation. The power management solution is required to monitor the DAC inputs and respond to VID voltage transitions in a controlled manner, supervising the safe output voltage transition within the DAC range of the processor without discontinuity or disruption. The ISL6559 checks the five VID inputs at the beginning of each switching cycle. If the VID code has changed, the controller waits one complete switching cycle to validate the new code. If the new code is stable during this one cycle delay, then the controller begins incrementing the reference voltage toward the new DAC code in 25mV steps, every two switching-cycles, until the new DAC code is reached.

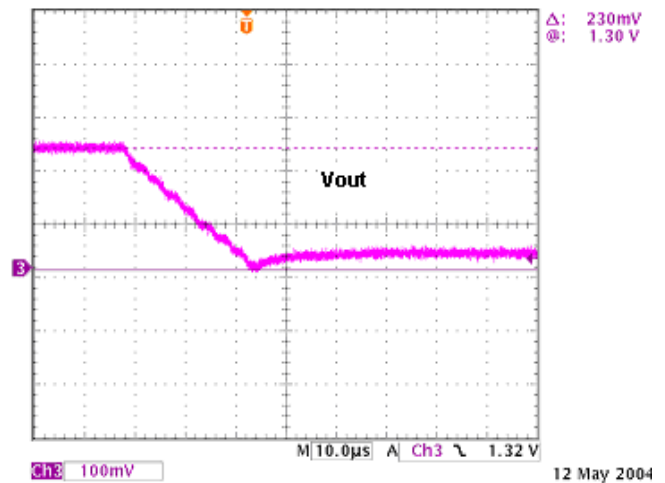

FIGURE 6. VID-ON-THE-FLY TRANSITION FROM 1.55V TO 1.30V

Figure 6 shows a 250mV DAC change prompted by changing VID3 and VID1 simultaneously. Originally at 1.550V (00000), the core voltage ramps to the new DAC setting of 1.300V (01010). The VID-on-the-Fly transition is completed in  $30\mu s$ , well within the  $100\mu s$  maximum window allowed. The converter is supporting a 26A load during the transition. The cursors on the scope shot reflect only a 230mV transition because the transition happened very fast and the final voltage was not captured.

Figure 7 shows the converter returning to a DAC level of 1.550V after the VID3 and VID1 states are returned to ground. Again, the converter is loaded at 26A during the DAC change.

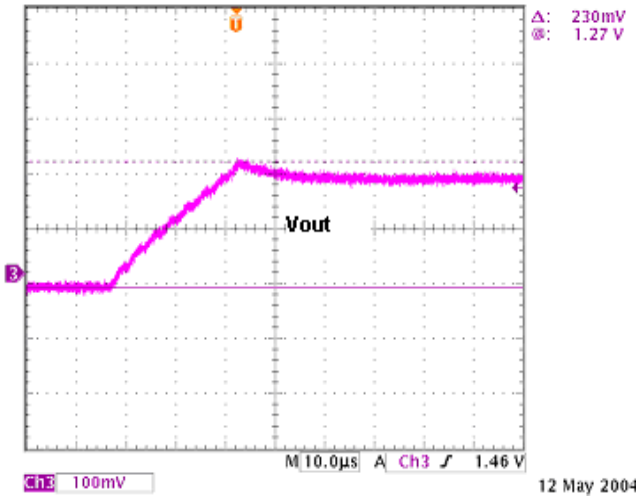

FIGURE 7. VID-ON-THE-FLY TRANSITION FROM 1.30V TO 1.55V

**Efficiency**

The efficiency of the ISL6559EVAL1 board, loaded up to 100A is plotted in Figure 8. Measurements were performed at room temperature and taken at thermal equilibrium with 400 LFM of air and heatsink. The design exceeds the AMD Hammer Desktop minimum requirements of 50% efficiency under minimum loading and 80% efficiency at maximum loading.

Additional testing was performed in a wind tunnel where we were able to achieve a 120A constant load at 45°C ambient and 300LFM of airflow. The board temperature was monitored and stabilized at around 100°C.

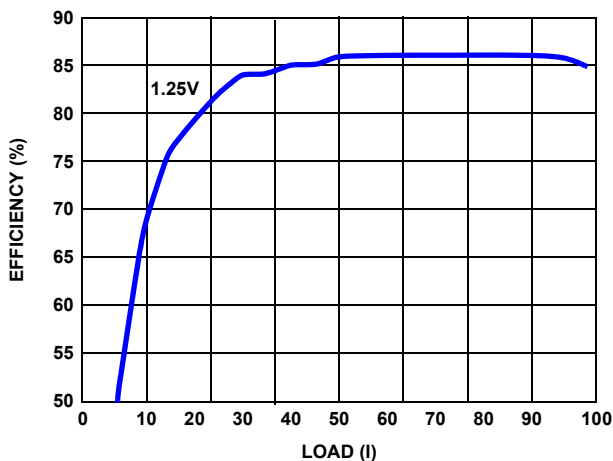

FIGURE 8. VRM EFFICIENCY vs LOAD CURRENT

**Adapting Circuit Performance**

Higher  $r_{DS(ON)}$  MOSFETs can be employed in the design, if the cost curve must be tilted lower. The tradeoff for lowering

cost is reduced thermal and efficiency performance of the solution. Select an upper MOSFET with an  $r_{DS(ON)}$  no larger than  $12m\Omega$  and keep the total gate charge below 15nC. This combined with a lower MOSFET of no more than  $7m\Omega$  with a total gate charge of 50nC to 70nC can provide a cost effective and thermally acceptable solution.

**Summary**

The ISL6559EVAL1 is an adaptable evaluation tool which showcases the performance of the ISL6559 and ISL6605 chip set. Designed to meet the performance requirements of AMD’s Hammer Family Desktop microprocessors, the board allows the user the flexibility to configure the board for current as well as future microprocessor offerings. The following pages provide a schematic of the board, bill of materials and layout drawings to support implementation of this solution.

**References**

Intersil documents are available on the web at <http://www.intersil.com/>.

[1] ISL6559 Data Sheet, Intersil Corporation, File No. FN9084.

[2] ISL6605 Data Sheet, Intersil Corporation, File No. FN9091.

# Schematic

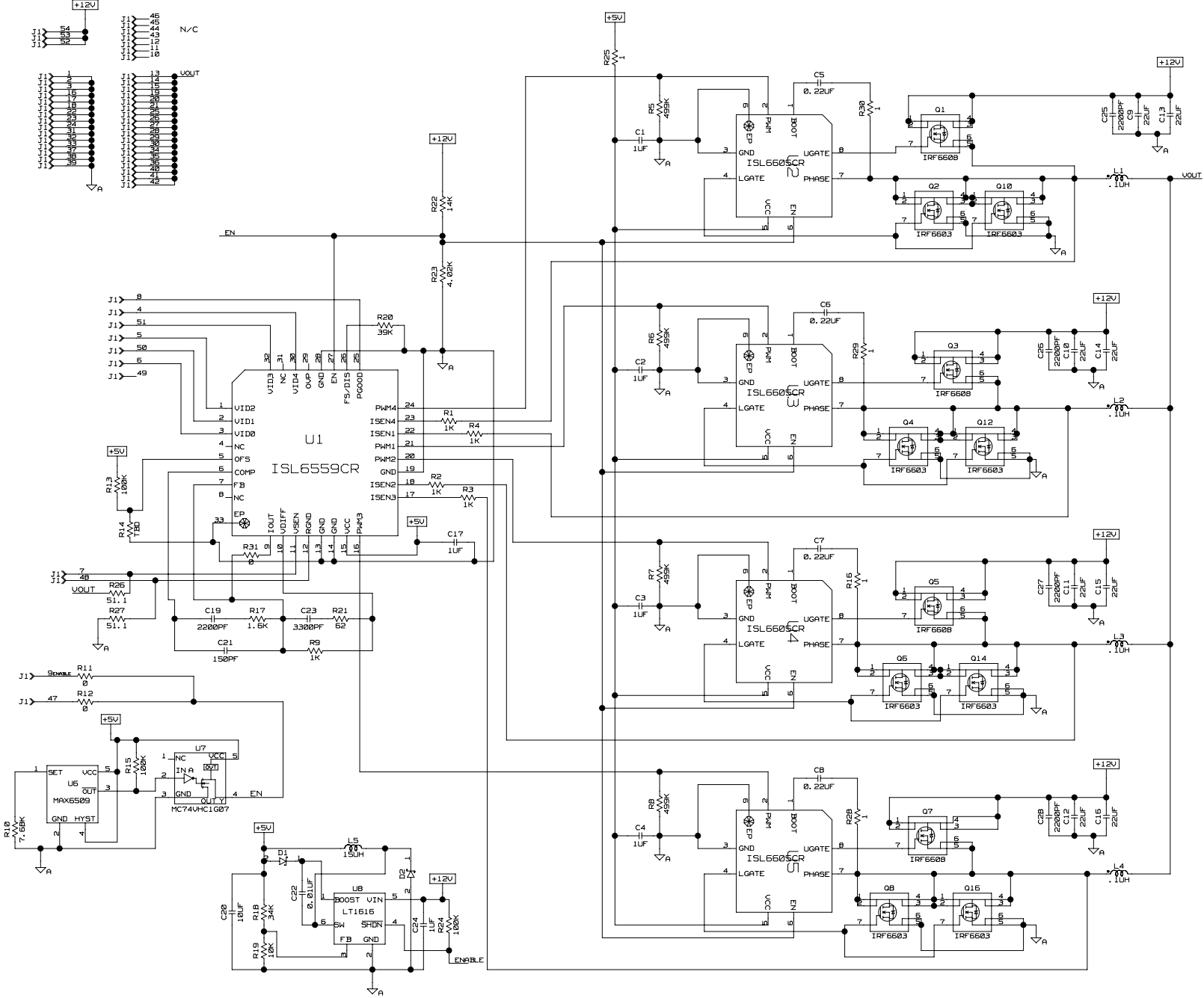

ISL6559EVAL1 Layout

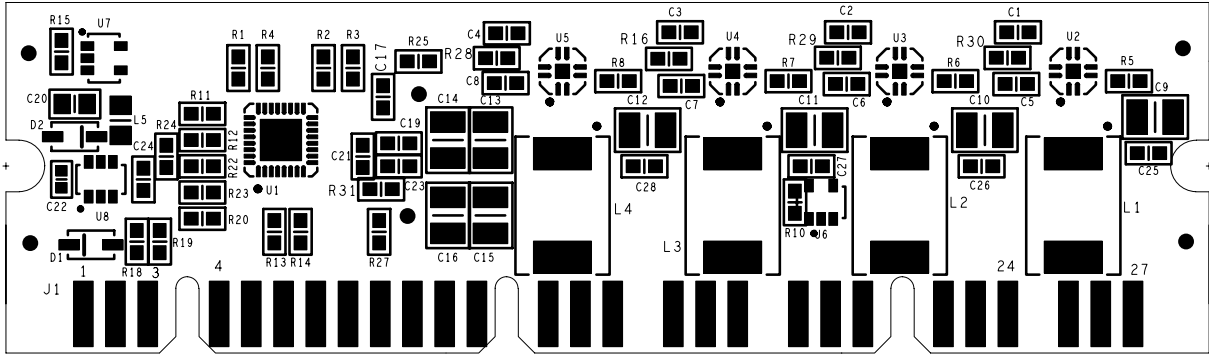

INTERMIL CORPORATION  
 PART # ISL6559EVAL1 REVA  
 DATE 02/20/2004

FIGURE 9. TOP

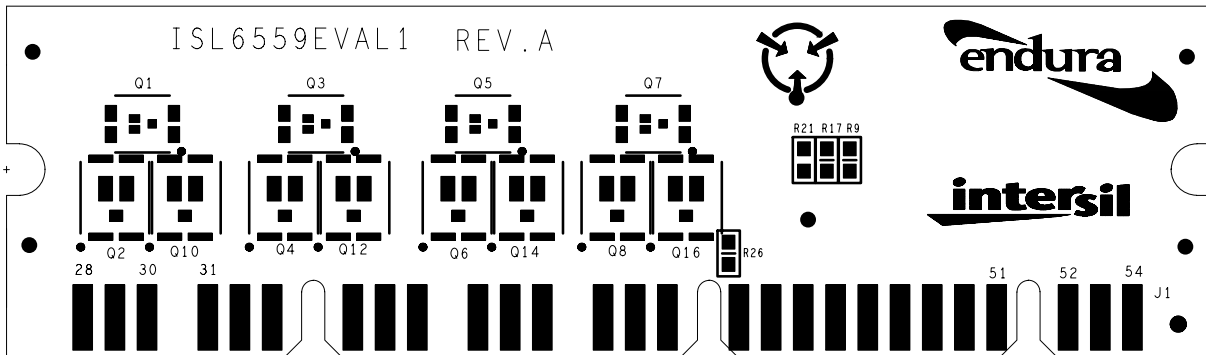

INTERMIL CORPORATION  
 PART # ISL6559EVAL1 REVA  
 DATE 02/20/2004

FIGURE 10. BOTTOM

# VRM Test Board Schematic

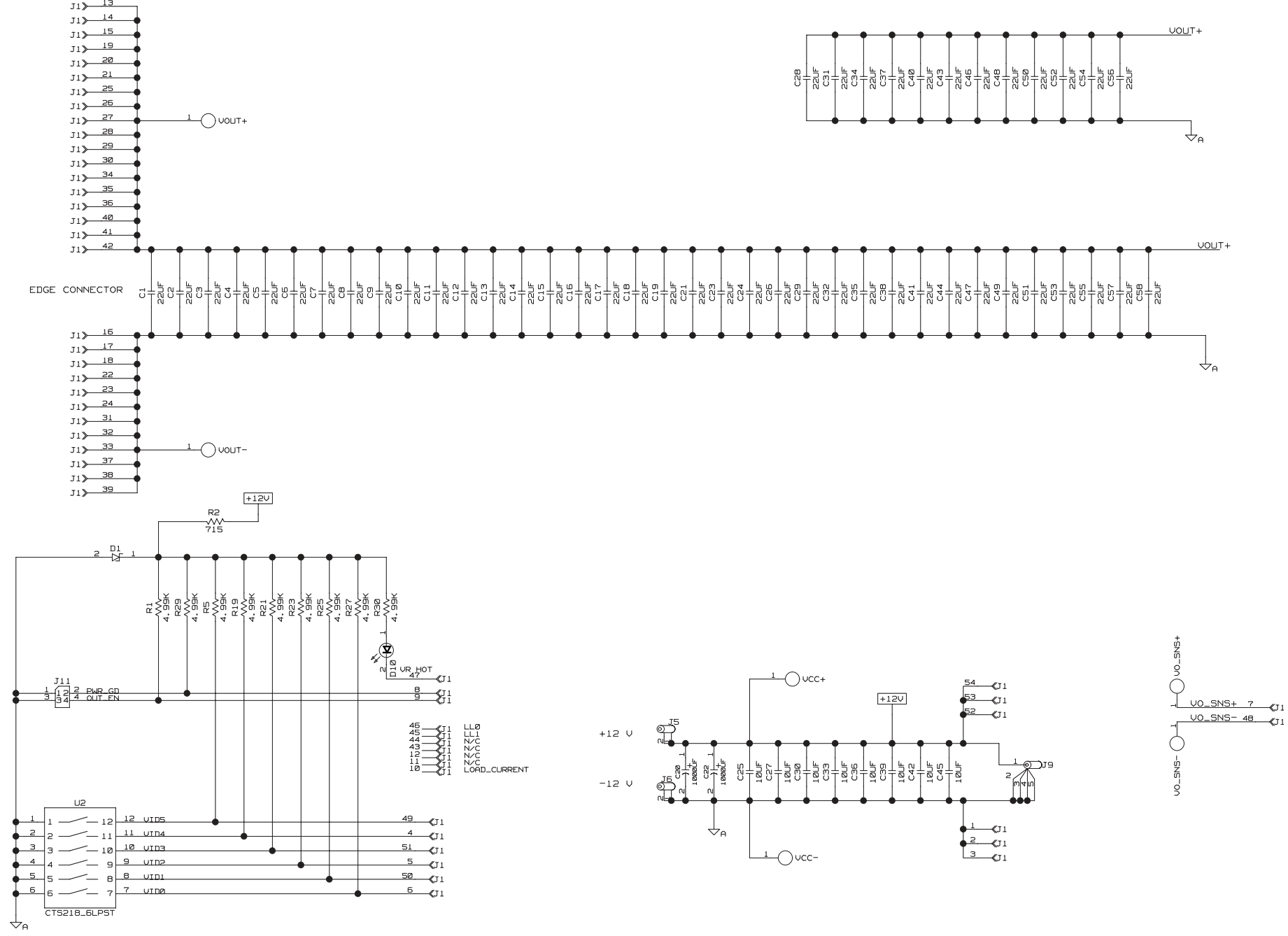



# VRM Test Board Schematic

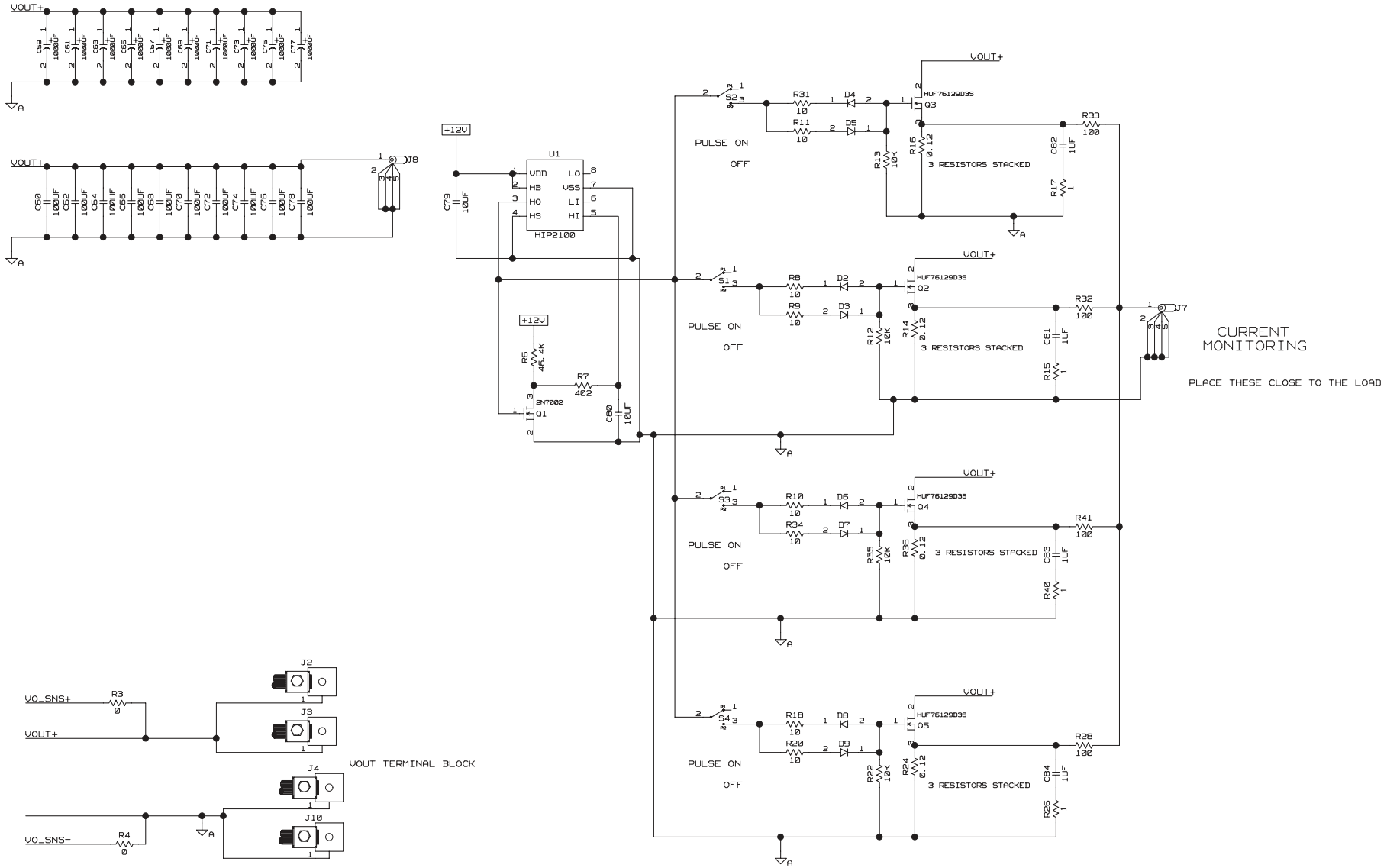

## Application Note 1132

### Bill of Materials

QTY	REFERENCE	COMPONENT	DESCRIPTION/COMMENT	MFG NAME	MFG NUMBER
1	C22	H1044-00103-25V8020-T	Capacitor, SMD, 0402, 0.01µF, 25V, +80-20%, Y5V	Panasonic	ECJ-0EF1E103Z
				Venkel	C0402Y5V250-103ZNE
6	C1-C4, C17, C24	H1045-00105-16V20-T	Capacitor, SMD, 0603, 1µF, 16V, 20%, Y5V	Murata	GRM188R61C105KA12D
				Venkel	C0603Y5V160-105MNE
1	C21	H1045-00151-50V5-T	Capacitor, SMD, 0603, 150pF, 50V, 5%, NPO	Panasonic	ECJ-1VC1H151J
				Venkel	C0603C0G500-151JNE
5	C19, C25-C28	H1045-00222-50V10-T	Capacitor, SMD, 0603, 2200pF, 50V, 10%, X7R	Panasonic	ECJ-1VB1H222K
				Samsung	CL10B222KBNC
				TDK	C1608X7R1H222K
				Venkel	C0603X7R500-222KNE
4	C5-C8	H1045-00224-10V10-T	Capacitor, SMD, 0603, 0.22µF, 10V, 10%, X7R	AVX	0603YC224KAT2A
				TDK	C1608X7R1C224K
				Venkel	C0603X7R100-224KNE
1	C23	H1045-00332-50V10-T	Capacitor, SMD, 0603, 3300pF, 50V, 10%, X7R	BC Components	0603B332K500BT
				Venkel	C0603X7R500-332KNE
1	C20	H1046-00106-6R3V10-T	Capacitor, SMD, 0805, 10µF, 6.3V, 10%, X5R	Venkel	C0805X5R6R3-106KNE
8	C9-C16	H1082-00226-16V20-T	Capacitor, SMD, 1210, 22µF, 16V, 20%, X5R	AVX	1210YD226MAT2A
				Murata	GRM32ER61C226ME20L
				Taiyo Yuden	EMK325BJ226MM (X7R)
				TDK	C3225X5R1C226M
				Venkel	C1210X5R160-226MNE
4	L1-L4	FP4-100	Coil-Pwr Inductor, SMD, 10X6.8mm, 0.1µH, 64A	Cooper Bussmann	FP4-100
				Cooper Electronic Tech.	FP4-100
				BI Technologies	HM00-03852
1	L5	PM1210-150J	Coil-Inductor, SMD, 1210, 15µH, 10% @ 2.52MHz	J.W. Miller	PM1210-150J
2	D1, D2	MBR0540T1-T	Diode-Rectifier, TH, TO220, 2PIN, 45V, 7.5A	Motorola	MBR0540T1-T
1	U1	ISL6559CR	IC-2-4 Phase Buck Controller, 32P, MLFP, 5X5	Intersil	ISL6559CR
4	U2-U5	ISL6605CR	IC-P6 HV Synch Buck MOSFET, 8P, QFN, 3X3	Intersil	ISL6605CR
1	U8	LT1616ES6	IC-Switching Regulator, 6P, SOT23, 0.6A, 1.4	Linear Technology	LT1616ES6
1	U6	MAX6509HAUK-T	IC-Temp.Switch, 5P, SOT23, 2.7-5.5V	Maxim	MAX6509HAUK
1	U7	MC74VHC1G07DT	IC-Non-Inverting Buffer, 5P, SOT23-5	On Semiconductor	MC74VHC1G07DT
8	Q2, Q4, Q6, Q8, Q10, Q12, Q14, Q16	IRF6607	Transis-PwrMOS, N-Channel, SMD, 2P, S0-8, 30V	International Rectifier	IRF6607
				International Rectifier	IRF6603
				International Rectifier	IRF6618

## Application Note 1132

### Bill of Materials (Continued)

QTY	REFERENCE	COMPONENT	DESCRIPTION/COMMENT	MFG NAME	MFG NUMBER
4	Q1, Q3, Q5, Q7	IRF6608	Transist-MOS, N-Channel, SMD, DIRECTFET, 30V	International Rectifier	IRF6608
5	R16, R25, R28-R30	H2511-00010-1/16W5-T	Resistor, SMD, 0603, 1 $\Omega$ , 1/16W, 5%, TF	Venkel	CR0603-16W-1R0JT
1	R21	H2511-00620-1/10W5-T	Resistor, SMD, 0603, 62 $\Omega$ , 1/10W, 5%, TF	Panasonic	ERJ-3GEYJ620V
				Venkel	CR0603-16W-620JT
3	R11, R12, R31	H2511-00R00-1/16W-T	Resistor, SMD, 0603, 0 $\Omega$ , 1/16W, 5%, TF	Panasonic	ERJ-3GEY0R00V
				Venkel	CR0603-16W-000T
5	R1-R4, R9	H2511-01001-1/16W1-T	Resistor, SMD, 0603, 1K, 1/16W, 1%, TF	Panasonic	ERJ-3EKF1001
				Samsung	RC1608F1001CS
				Venkel	CR0603-16W-1001FT
1	R19	H2511-01002-1/16W1-T	Resistor, SMD, 0603, 10K, 1/16W, 1%, TF	Cal-chip	RM06F1002CT
				Panasonic	ERJ-3EKF1002V
				Venkel	CR0603-16W-1002FT
2	R15, R24	H2511-01003-1/16W1-T	Resistor, SMD, 0603, 100K, 1/16W, 1%, TF	Panasonic	ERJ-3EKF1003
				Venkel	CR0603-16W-1003FT
1	R13	H2511-01003-1/16W5-T	Resistor, SMD, 0603, 100K, 1/16W, 5%, TF	Dale	CRCW0603-104JRT1
1	R22	H2511-01402-1/16W1-T	Resistor, SMD, 0603, 14K, 1/16W, 1%, TF	NIC Comp Corp.	NRC06F1402TR
				Panasonic	ERJ-3EKF1402V
1	R17	H2511-01601-1/16W5-T	Resistor, SMD, 0603, 1.6K, 1/16W, 5%, TF	Panasonic	ERJ-3GEYJ162V
				Venkel	CR0603-16W-1601JT
1	R18	H2511-03402-1/16W1-T	Resistor, SMD, 0603, 34K, 1/16W, 1%, TF	Panasonic	ERJ-3EKF3402V
				Venkel	CR0603-16W-3402FT
				Yageo	9C06031A3402FKHFT
1	R20	H2511-03902-1/10W5-T	Resistor, SMD, 0603, 39K, 1/10W, 5%, TF	Panasonic	ERJ-3GEYJ393V
				Venkel	CR0603-16W-393JT
1	R23	H2511-04021-1/16W1-T	Resistor, SMD, 0603, 4.02k $\Omega$ , 1/16W, 1%, TF	Panasonic	ERJ-3EKF4021V
				Venkel	CR0603-16W-4021FT
4	R5-R8	H2511-04993-1/16W1-T	Resistor, SMD, 0603, 499K, 1/16W, 1%, TF	Panasonic	ERJ-3EKF4993V
				Venkel	CR0603-16W-4993FT
2	R26, R27	H2511-051R1-1/16W1-T	Resistor, SMD, 0603, 51.1 $\Omega$ , 1/16W, 1%, TF	Panasonic	ERJ-3EKF51R1V
				Venkel	CR0603-16W-51R1FT
				Vishay	CRCW060351R1F100
1	R10	H2511-07681-1/16W1-T	Resistor, SMD, 0603, 7.68K, 1/16W, 1%, TF	Panasonic	ERJ-3EKF7681V
				Venkel	CR0603-16W-7681FT
				Yageo	9C06031A7681FKHFT
1	Heatsink			Wakefield	

Intersil Corporation reserves the right to make changes in circuit design, software and/or specifications at any time without notice. Accordingly, the reader is cautioned to verify that the Application Note or Technical Brief is current before proceeding.

For information regarding Intersil Corporation and its products, see [www.intersil.com](http://www.intersil.com)