

DAQ on a Stick, Strain Gauge with Programmable Chopper Stabilized IN-Amp

Introduction

The “DAQ on a Stick, Strain Gauge with Programmable INAMP” is one of a series of reference designs highlighting Intersil’s precision products with different microcontrollers. This reference design is a self contained demo showing a complete signal chain solution using Intersil parts and a Renesas microcontroller. The complete reference design is conveniently housed in a USB stick form factor. This compact design draws power through the USB port and uses a Graphical User Interface (GUI) to display the real time voltage readings from a bridge strain gauge or a user supplied sensor. Figure 1 shows the Data Acquisition (DAQ) on a Stick connected to an external foil strain gauge.

Figure 2 shows a simplified schematic of the Strain Gauge design. The design uses Intersil’s ISL28634 Programmable Instrumentation Amplifier (INAMP), ISL23328 Digital Potentiometer, ISL28233 Operational Amplifiers, ISL43741 Differential Mux, ISL21010 4.096 Voltage Reference, the ISL26104 24-bit Delta Sigma Converter and Renesas R5F10JBC (RL78/G1C) Microcontroller.



FIGURE 1. DAQ ON A STICK WITH STRAIN GAUGE

Ordering Information

PART NUMBER	DESCRIPTION
ISLRE-BDGSTKEV1Z	Evaluation Board

Getting Started

Installation of the Graphical User Interface (GUI) Software and USB Drivers

The GUI Software and USB drivers have to be installed on a PC running Windows NT/2000/XP/Vista/Win7/Win 8 operating system before connecting the ISLRE-BDGSTKEV1Z evaluation board to the USB port.

The software and a quick video on the operation of this application demo can be downloaded or viewed from the Intersil website at <http://www.intersil.com/en/tools/reference-designs/Renesas-ISL28634-strain-gauge-reference-design.html>.

Video Clip

A quick video clip is provided in the previous web link. This video will walk the user through the process of loading the software and use of the GUI.

Loading Software

From the website, click on the document tab then click on the Renesas DAQ on a Stick Software link to load the executable. Follow the on-screen instructions to complete the software installation. The installation program places the user interface software in the C:\Program Files\IntersilRenesas_InAmp_DAQ directory. To create a shortcut on your desktop, check the “Create A Desktop Icon” box during the software installation. Launch the application by checking the “Launch Intersil Renesas DAQ on Stick” box, then click the “Finish” button.

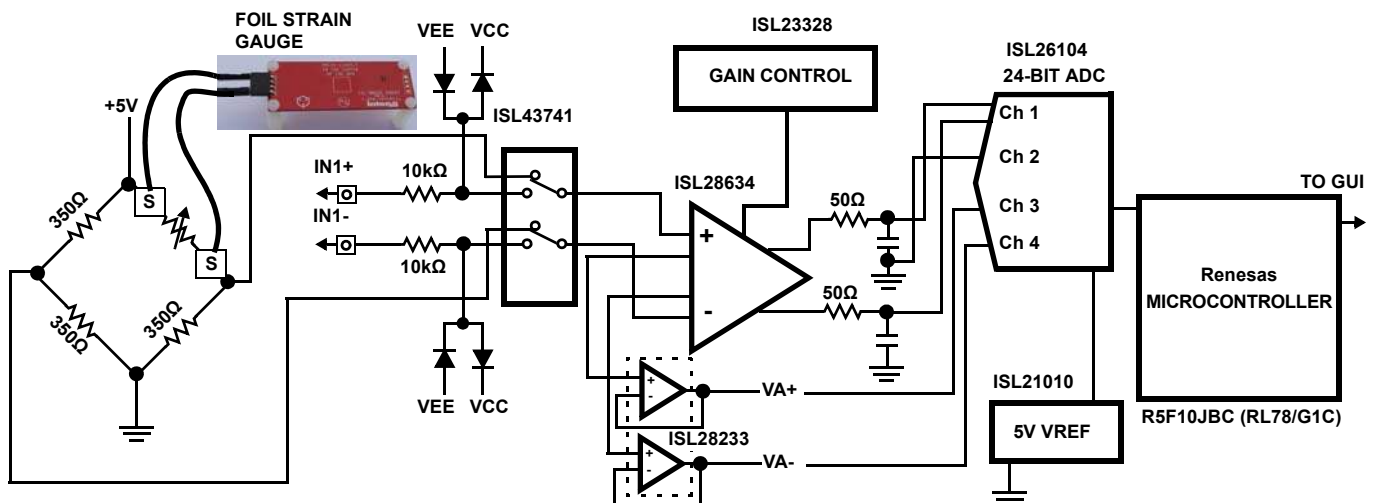

FIGURE 2. SIMPLIFIED STRAIN GAUGE SCHEMATIC

Running the Evaluation Software

After software has been installed, and the setup screen in Figure 5 appears, plug the ISLRE-BDGSTKEV1Z board into a USB port on the computer.

The green LED on the DAQ on a Stick board should be on at this time. When the software starts, the Startup Screen shown in Figure 5 will appear. With the DAQ on a Stick connected, the USB Status indicator will display “Connected 0x2033”. The assigned HID PID code for this application is 0x2033. This is verification the software is communicating with the board.

If the DAQ on a Stick is not connected, or a problem exists with the demo, the message will read “HID Device Not Found”. If this occurs, click on the “Test USB Connection” button to see if this enables the connection. If not, try disconnecting and re-connecting the device or restarting the software.

From the Startup Screen (Figure 5), the user can click on the Instantaneous Voltage button to get a single voltage reading, select the sensor input they want to measure and adjust the gain of the amplifier, or click the Start button to go to the Measurement Display screen, as shown in Figure 6, “GUI MEASUREMENT SCREEN,” on page 4. At this point the green LED on the board will go off.

For future use of the software, click on the Intersil DAQ shortcut (created in the previous step) on the desktop. Figure 3 shows the desk top icon.



FIGURE 3. DESKTOP ICON

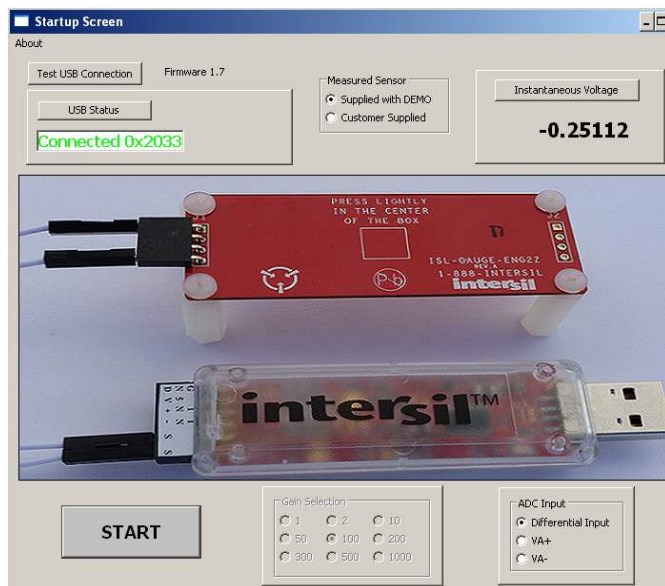

FIGURE 4. GUI START-UP SCREEN

Connecting the Sensor

The ISLRE-BDGSTKEV1Z reference design gives the user the option to measure the strain on an internal Bridge with a foil gauge (supplied with the evaluation board) or connect an external sensor and monitor the voltage reading on the GUI screen. The user will select the “Supplied with the Demo” sensor or “Customer Supplied” sensor by clicking the appropriate radial button at the top of Figure 5. The “Supplied with the Demo” sensor (foil gauge) is the default value in the GUI with a gain of 100V/V. Figure 5 shows the external connector inputs, which are used to connect the sensor to the circuit shown in Figure 2 on page 1.

Foil Strain Gauge

1. To connect the foil gauge supplied with the evaluation board, plug the wires into the “S” ports (either top row or the bottom row, the columns are connected) on the DAQ Stick.
2. Connect the opposite end of the wires to the far edges of the foil gauge board (See Figure 5).

User Supplied Sensor

1. To connect a user supplied sensor, plug the wires into the IN+ and IN- ports as shown in Figure 5, then select the “Customer Supplied” option. This will cause the ISL43741 differential mux to switch the inputs. Once the Customer Supplied option is selected, the user will have the option of changing the amplifiers’ gain for the best measurement.
2. The DAQ on a Stick also provides a 5V supply and Ground connection for use by the customer’s sensor network.

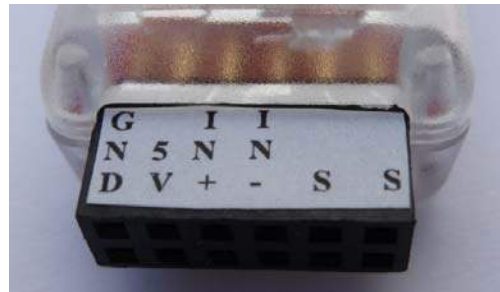

FIGURE 5. SENSOR CONNECTOR

Overview of Demonstration Software

The following is an overview of the demonstration software. The primary goal of the software is to provide a real-time graphical display of data collection. To do this, two GUI screens are used. The Startup Screen (Figure 5) is used for the following: verify software is communicating with the board, select the sensor to be measured, select gain of the system (if the “Customer Supplied” sensor is selected) and select the input to the ADC. Once these items are selected, the User can click on the “Start” button to proceed to the Measurement screen (Figure 6).

The Measurement screen provides the following abilities: take/view measurement data, select the units of measure (either volts or microstrain), calibrate the initial reading to zero, and adjust the range of both the x and y axis of the graph. The screen also supplies a means to “Export” the collected data for further analysis.

Startup Screen General Discussion

Test USB Connection Button

As previously discussed, the Test USB Connection button performs the USB Connection sequence. The version of the firmware is automatically listed beside the Test USB Connection button.

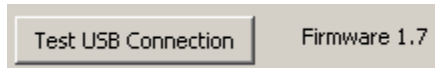

Instantaneous Voltage Button

The Instantaneous Voltage button performs an immediate read of the ADC.

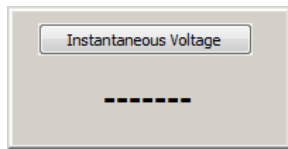

The button provides a further sanity check that the evaluation board is functional.

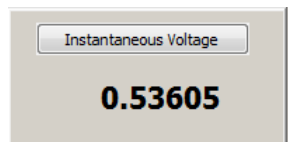

Measured Sensor Radio Box

Measured Sensor is a two selection "Radio Box." A radio box enables only one active selection at a time.

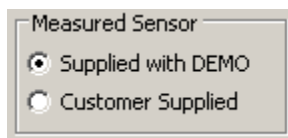

In this case the choices are "Supplied with DEMO" and "Customer Supplied". If "Supplied with DEMO" sensor is selected, the gain of the amplifier is fixed at 100 and the gain selection box is grayed out. If the "Customer Supplied" sensor is selected, the amplifier gain can be changed using the Gain Selection box.

Gain Selection Radio Box

When the User selects the "Customer Supplied" sensor option, the "Gain Selection" radio box is enabled and the user can now select from 1 of 9 programmable gains of the ISL28634 Programmable Instrumentation Amplifier. Other gain options available, see full Data sheet for ISL28533/ISL28633 family of Instrumentation Amplifiers.

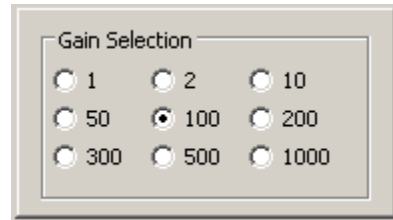

ADC Input Radio Box

The ISL26104 is a quad input 24 bit ADC. The input is selected by clicking on the radio box button in the ADC Input box shown above.

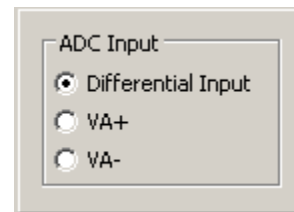

Selecting the Differential Input connects the channel measuring the output of the PGIA. Selecting the VA+ or VA- radial button measures the output of either the VA+ or the VA- pin. The VA+ and VA- pins are provided to be able to assess the health of the sensor or to use the pre-summing difference signal for advanced digital compensation.

Startup Screen "Menu Bar"

At the top of the Startup Screen is the "Menu" bar. Clicking on "About" will reveal a drop down menu that opens a new window with information about the GUI version and the firmware version.

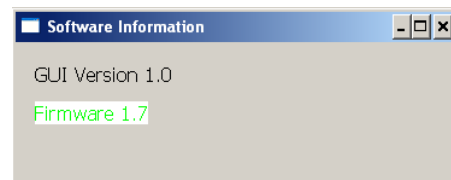

Start Button to Measurement Display Screen

The "Start" button at the bottom left of the Startup Screen loads the "Measurement Display" screen shown in Figure 6.



Measurement Display Screen General Discussion

Once the “Start” button is clicked on the Startup Screen, the Measurement Display Screen will appear (Figure 6). From this screen the user can do the following: start/stop data collection, select the scaling of the Y axis [Voltage (V) or Microstrain (g)], adjust the scaling of the X and Y axes [“Automatic” or “Manual”], and remove any offsets with the “Calibrate” button.

Additional functionality is provided in the Menu items at the top of the Measurement Screen in the “menu bar”.

Data Collection Radio Box

This radio box is one of the most actively used controls.

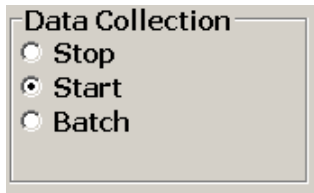

One of three selections is possible. Start begins Data Collection and graphing in real time of the measured ADC values. Stop halts data collection and Batch enters a “Capture then Display” mode where data is collected for 1024 measurements and then displayed all at once. Batch mode is used to collect periodic waveforms where the overhead of real-time graphing would result in missed measurements. Reference section “Measuring Batch Mode Throughput” on page 9.

Graphing Radio Box

If the user selects “Supplied with Demo” sensor from the Startup Screen, they have the option of displaying the measured strain in either Voltage or Microstrain as shown. To select the units to be displayed, click on the radial button Graph (V) or Graph (g). Reference section titled “Measurement in Microstrain” for the calculation to get microstrain units in grams on page 6.

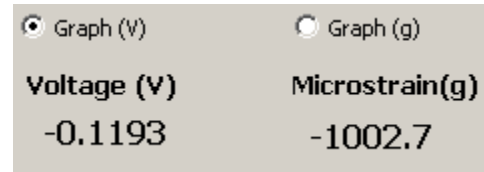

If the user selects “Customer Supplied” sensor from the Startup Screen, the reading is automatically displayed in Voltage and the Graphing Radio Box will look like this.

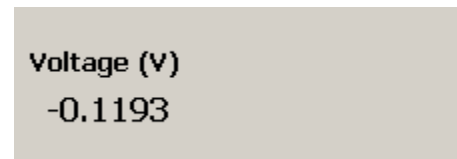

In either case, the measured ADC Voltage (V) and Microstrain (g) are updated in the display below the radial buttons (shown in bold font) as data collection proceeds.

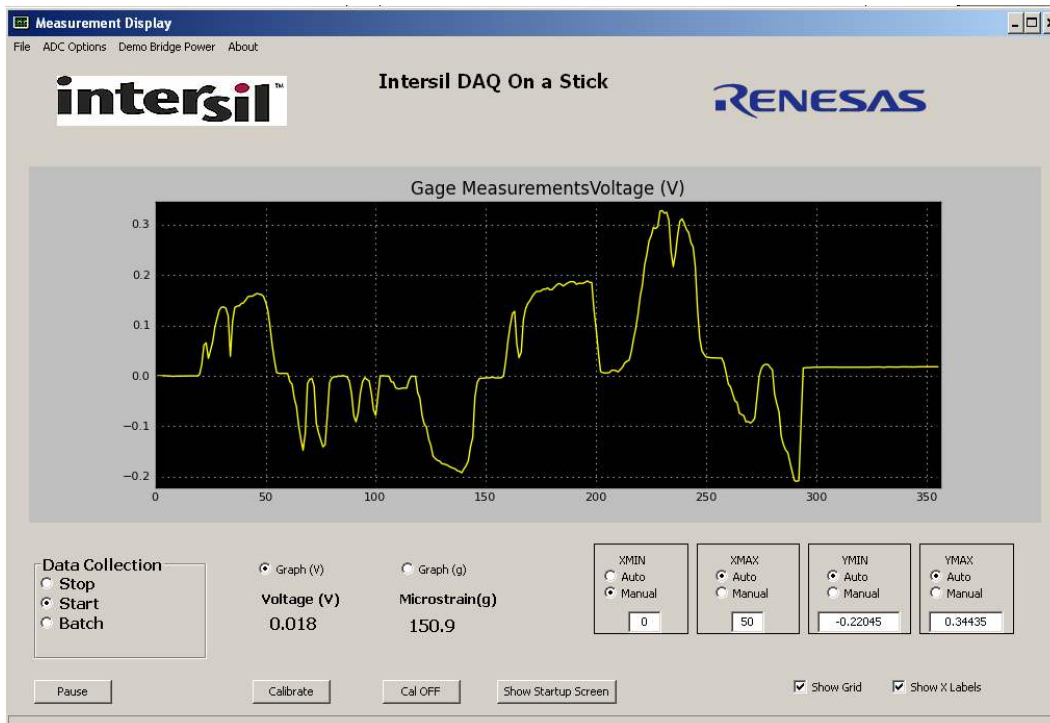

FIGURE 6. GUI MEASUREMENT SCREEN

Application Note 1853

Calibrate Button

The “Calibrate” button is used to remove an offset from the measured ADC value in volts.



This helps to give an accurate reading from time zero and is required because the board does not always return to the same deflection point after a strain is applied to the board. If “Calibrate” is selected, the initially measured value is subtracted from all subsequent ADC Voltage readings. To return back to the non-calibrated condition, click on the “Cal OFF” button. Note: the calibrated offset value is saved at the top of the exported .csv files, along with ADC sample/sec, channel being measured, status of flushing, Gauge Factor, Gain and Gain Factor.

Graphing X and Y Axis Control

These windows enable control of the graph area horizontal (XMIN, XMAX) and vertical (YMIN, YMAX) axes.

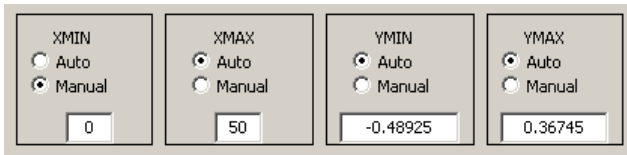

With “Auto” selected, the last 50 measurements are displayed as data collection runs. This produces a horizontal scrolling of the data.

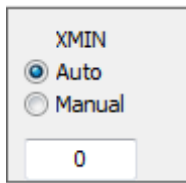

To see the history of the sensor reading from the beginning, pin the x axis to 0 by clicking the manual button in the XMIN box with the value in the selection window at 0.

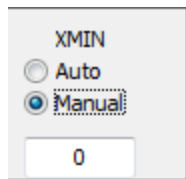

Typing in another value jumps to that location.

The Y axis are automatically adjusted as data is collected. However, when graphing “flat line” waveforms, the user can select “Manual” while data collection is running and zoom the Y axis in to see further detail.

During initialization, the controls are set to “Auto.” Once started, the user can select the “Manual” radial button and change the Y axis as desired.

Note that the axis controls only affect the graph display area. During data export, all data collected, regardless of graph scaling, is sent to the .csv file.

Grid and X Labels Check Boxes

These are graphing display options. Disabling (un-checking) “Show Grid” or “Show X Labels” will speed up real-time graphing display. These options can be enabled/disabled at any time.



Show Startup Screen Button

This button will result in the re-display of the “Startup” screen.



If clicked more than once, the Startup form may be hidden behind the “Measurement Form.” In this case, merely move the forms around so both can be viewed at once.

Measurement Display Menu Options

The Measurement Display has a “Menu” bar at the top.



Major categories for the Menu are: “File” for exporting collected data to a .csv file or capturing a picture of the graph display. “AD Options” for setting the ADC Sample rate, the ADC Channel and Enabling/Disabling “Flushing” during real-time data collection. (Flushing is always disabled when using Batch mode data collection.) Reference section “Real Time Graph Options and Flushing” on page 9. “Demo Bridge Power” turns on and off the power provided from the DAQ on a Stick. “About” shows the schematic of the DAQ on a Stick and offers another way for the User to read the firmware version. Below is discussion on these menu items.

File

The “File” menu enables the user to save an image of the Graph “Save Chart” or export the collected data to a “.csv” file for import into other applications.

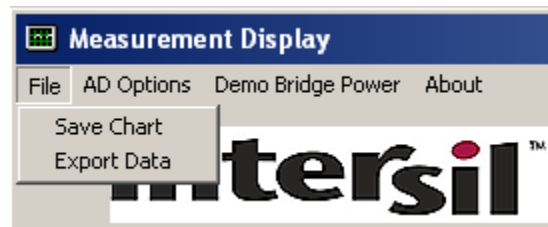

AD Options

The “AD Options” menu has three main areas that are made up of radio box selections “AD Word Rate” programs the ISL26104 ADC with a samples per second value. One can review the ISL26104 data sheet for more detail on sampling rates. “ADC Input” selection determines which ISL26104 channel is measured; Channel 1 is the output of ISL28634, Channel 2 has both inputs grounded, Channel 3 is the VA+ output of the ISL28634 and Channel 4 is the VA- output of the ISL28634.

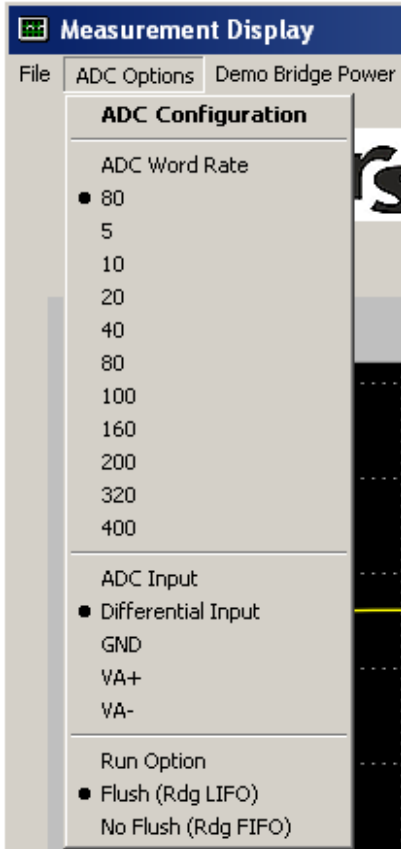

Demo Bridge Power

The “Demo Bridge Power” menu turns the power to the internal bridge, provided from the DAQ on a Stick (Figure 4, “GUI START-UP SCREEN,” on page 2), on and off.

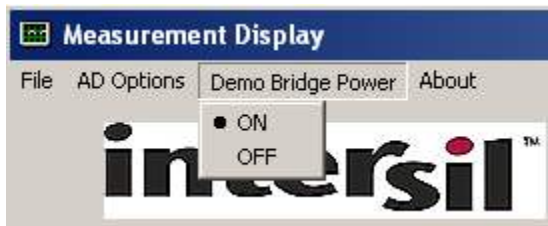

About

The “About” menu provides a schematic of the DAQ on a Stick circuit and provides another path, other than the one on the Startup Screen, to see the version of the GUI and firmware.

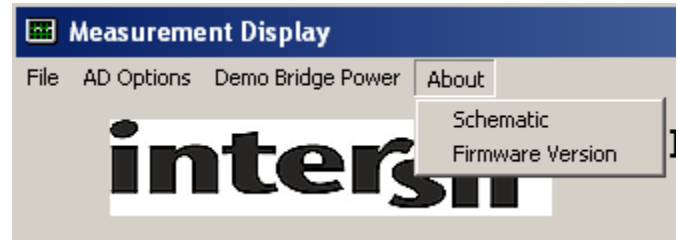

Measurement in Microstrain

Voltage and Calculated Measurement Discussion

If the user selects “Supplied with Demo” sensor, they have the option of displaying the measured strain in either Voltage or Microstrain. The Microstrain (g) is calculated based on the characteristics of the Vishay Foil Strain gauge. The equation to calculate the microstrain units is shown in Equation 1.

$$\text{Microstrain(g)} = (A_V\text{PGIA}) \times \text{Cal}_{\text{FACTOR}} \times \text{Gain}_{\text{FACTOR}} \quad (\text{EQ. 1})$$

Where:

Microstrain = calibrated to be in grams.

$A_V\text{PGIA} = 100$, Gain of the ISL28634 in this configuration.

$\text{Cal}_{\text{FACTOR}} = 0.119\text{V}$ Empirically measured with 1kg weight.

$\text{Gain}_{\text{FACTOR}} = 84.033$ Value calculated so when the ADC's output is 0.119V the microstrain unit reads 1kg.

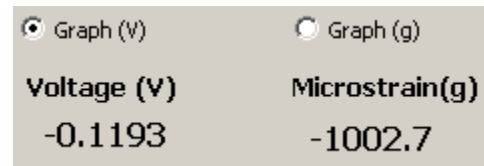

VOLTAGE AND CALIBRATION OFFSET

Voltage (V) is based on the raw ADC reading and does not include adjustments for Gain.

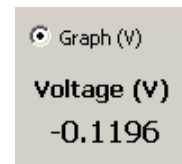

However, it can be affected if the user clicks the “Calibrate” button during data collection. The Calibrate button is designed to remove a fixed offset that may occur when a sensor is in a dormant condition.

Design Considerations

ISL28634

The ISL28634 is an ideal choice for the input amplifier for a strain gauge design. The 5V Zero-Drift Rail-to-Rail Input/Output programmable gain Instrumentation Amplifier has the following features: low offset, low noise, low gain error and high CMRR. The zero drift circuitry achieves low offset and gain error drifting. The logic interface allows up to 9 selectable gain settings. The differential output amplifier includes a reference pin to set the common mode output voltage to interface with differential input ADC.

ISL28233 Dual Micropower, Zero-Drift, RRIO

Operational Amplifier

The ISL28233 is a dual micropower, zero-drift operational amplifier that is optimized for single supply operation from 1.65V to 5.5V. The low supply current of 18 μ A and wide input range enable the ISL28233 to be an excellent general purpose op amp for a variety of applications.

ISL26104 24-bit ADC

The ISL26104 is a complete analog front-end with quad differential multiplexed inputs for high resolution measurements. The ISL26104 features a third order modulator providing up to 21.4-bit noise-free performance (10Sps). The 24-bit delta-sigma analog-to-digital converter includes a very low-noise amplifier with programmable gain. Although this application demo uses an input buffer amplifier (ISL28634), the high input impedance of the ISL26104 allows direct connection of sensors, such as load cell bridges to ensure the specified measurement accuracy without a buffer amplifier. In order to initiate a correct power-up reset, diode D1, resistor R3 and capacitor C8 implement a simple RC delay to ensure the $\overline{\text{PDWN}}$ transitions from low-to-high after both power supplies have settled to specified levels.

ISL21010 (4.096V)

The ISL21010CFH341 is a precision 4.096V, low dropout micropower bandgap voltage reference. It provides a $\pm 0.2\%$ accurate reference. The ISL21010 provides up to 25mA output current sourcing with low 150mV dropout voltage. The low supply current and low dropout voltage combined with high accuracy make the ISL21010 ideal for precision low powered applications.

ISL43741 Differential 4-to-1 Multiplexer

The ISL43741 is a precision, bidirectional, differential 4-channel multiplexer/demultiplexer. The mux is designed to operate from a single +2V to +12V supply or from $\pm 2\text{V}$ to $\pm 6\text{V}$ supplies. The ISL43741 has low charge injection with 1pC (Max) at $V_S = \pm 5\text{V}$.

ISL23328 Volatile, 128 tap, I²C Digital Potentiometer

The ISL23328 has a VLOGIC pin allowing operation down to 1.2V on the bus, independent from the VCC value. This allows for low logic levels to be connected directly to the ISL23328 without passing through a voltage level shifter.

Reference Documents

- ISL28634 Data Sheet “5V Zero-Drift Rail-to-Rail Input/Output programmable gain Instrumentation Amplifier features,” [FN8364](#)
- ISL28233 Data Sheet “Dual Micropower, Zero-Drift, RRIO Operational Amplifier” [FN7692](#)
- ISL21010 Data Sheet “Micropower Voltage Reference,” [FN7896](#)
- ISL26104 Data Sheet “Low-Noise 24-bit Delta Sigma ADC,” [FN7608](#)
- ISL43741 Data Sheet “Low-Voltage, Single and Dual Supply, 8 to 1 Multiplexer and Differential 4 to 1 Multiplexer,” [FN6053](#)
- ISL23328 Data Sheet “Dual, 128-Tap, Low Voltage Digitally Controlled Potentiometer,” [FN7902](#)
- Renesas R5F10JBC [Data Sheet](#)

General Notes and Background

General Goals of the Demo

During Intersil's Signal Path Demonstrations, the primary goal is to provide a real-time graph display of data collection. The demo needs to be quickly responsive to changes in sensor readings as a human makes changes to the input. However, two primary items can lead to latency in the perceived time it takes the graph to respond.

REAL-TIME GRAPHING OVERHEAD

Creating a graph in real time involves instruction overhead. To the casual observer one can view the influence of graph overhead by enabling and disabling the “Grid” background. With the Grid enabled on, the graph will “scroll” more slowly than with Grid disabled.

USB BUFFERING AND FLUSHING

Another influence on real-time graphing is the buffering of USB pipe information. Buffering centers on the goal to avoid lost packets and/or decrease transfer Non-Acknowledge (NAK). NAKs lead to an increase in overhead of actual data throughput.

To avoid the latency introduced by buffering, a USB function known as “Flush Buffer” is available on the GUI side. When a “flush” is executed, essentially all buffered “reports” are tossed aside and the latest information is obtained by the GUI application on the next “USB Read” operation.

The advantage of flushing is that the latest influence of operator interaction is immediately available for graphing. Without flushing, several readings will be displayed before the operator interaction appears in the graph.

The influence of these delays can produce a hysteresis in the real-time graphing. They can lead to a time delay where the user presses on the strain gage, but the change is not displayed for a few seconds. This can result in confusion or dissatisfaction with performance during a demonstration.

Evaluation Board Firmware Discussion

During the initial development, a simple exchange was implemented. The GUI sent a USB request for a reading; the firmware received the request, got a reading and sent it. Later versions adopted the method where readings streamed continuously without the need for the application to repeat the request for another reading. Still later versions employed the ability to “start/stop” the streaming. This was so the ADC could be stopped, re-programmed to use a different channel or sampling rate, and started again.

AN OVERVIEW OF USB COMMUNICATIONS PARAMETERS

Communication between the GUI application and the evaluation board firmware is achieved over the USB bus. The evaluation board firmware complies with HID requirements of the Windows Operating System. No special driver is needed to communicate with the evaluation board firmware. The communications utilize the Windows built in USB “HID” driver. Both the Python GUI and the firmware make use of “Case” statements with the USB buffer being examined to enable various functions.

AD Sampling Rates and USB Flushing

Once programmed, the Intersil ISL26104 ADC is constantly making measurements and signaling the completion of each measurement. Most demonstrations have run with a sampling rate of 80 readings per second. However, while the ADC is completing readings at this rate, the overhead of real-time graphing and utilization of “flushing” means that not all measurements are actually being displayed. This is fine when dealing with sporadic operator influences and providing immediate feedback/display of those influences.

Conversely, if one is interested in re-production of a periodic signal such as a voltage ramp or sine wave, the primary goal of immediate display of sporadic changes fails. With periodic waveform analysis, the emphasis falls on the capture of an uninterrupted/complete batch of measurements, essentially leaving real-time and moving to a “Batch: capture then display” operation.

Benchmarking Application Measurement Throughput

As has been stated, the most recent firmware enables the transmission of all measurements. The firmware now employs an interrupt which triggers whenever the ADC has completed a reading. Upon this interrupt, the ADC reading is collected over the SPI interface and a “report” is scheduled for transmission over the USB.

Even with this firmware design, there was a need at the application end to monitor if indeed all readings are getting through. Overhead tied to Windows, USB HID and the application itself could result in missed measurements. Furthermore, different computers may run at slower speeds. Thus, a means of monitoring the performance of the total throughput is also needed. This so an individual user can assess the performance of a particular installation.

To meet this need, a fourth byte is also transmitted with the ADC reading. Tagged the “Firmware Count”, it is a single byte that is

incremented each time a reading is transmitted. This fourth byte enables the appraisal of the total application throughput. If all readings are being processed, a perfect sawtooth is seen as part of the measurement data shown in Figure 7. The value should count up, roll-over at 255 and repeat the process. Missing or skipped values indicate an incomplete measurement stream. “Firmware Count” is discussed in detail in the next section.

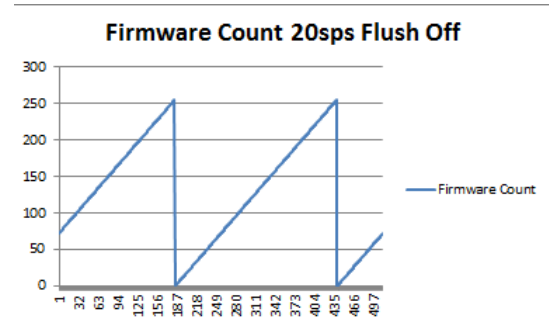

FIGURE 7. VERIFICATION OF THROUGHPUT

Measuring Throughput

A user may be interested in measuring how fast a specific installation of the Sensor Measurement application is running. The speed can be affected by Operating system, speed/type of processor and number of other windows or applications running concurrently.

Three pieces enter into throughput of Intersil demos. First, the firmware must be able to collect all measurements and transmit them over the USB. Second, the USB methodology (Speed and type of Pipe/Endpoints) should be able to accommodate the transmission/reception of all measurements. And third, the GUI needs to collect and display the information while other Windows applications may be open.

USING THE EXPORT DATA TO ANALYZE THE MEASUREMENT SPEED OF AN INSTALLATION

A user can perform empirical speed measurements via the “Export” function. The column for doing this is labeled “Firmware Count.”

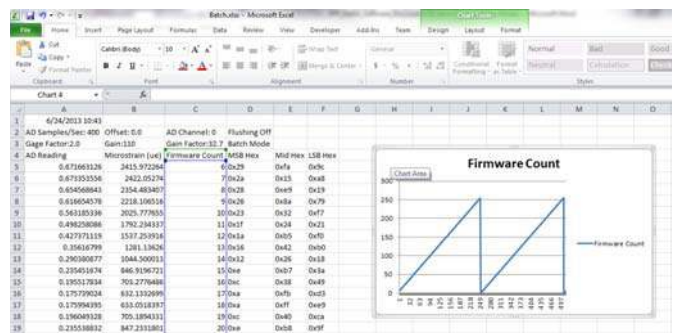

FIGURE 8. SAWTOOTH WHEN PLOTTING “FIRMWARE COUNT”

If all readings are being collected, the value in the column will count from 0 to 255, rollover to zero and start over. If the user plots this column, the graph should yield a perfect sawtooth waveform when all measurements are being collected.

Application Note 1853

MEASURING BATCH MODE THROUGHPUT

Developer tests on various installations indicate all measurements can be collected in “Batch” mode at up to 400SPs. (Samples Per Second). However this could vary from installation-to-installation. As can be seen in Figure 8, the “Exported” data should yield a sawtooth waveform in “Firmware Count” column.

REAL TIME GRAPH OPTIONS AND FLUSHING

With “Real-Time” graphing, it is possible to record all measurements, provided the Sample Rate is slow enough to accommodate Graphing and USB throughput overhead. Thus a “Flush On”/“Flush Off” selection is available in the user “AD Options” menu.

Figure 9 is a screen shot of a low frequency periodic ramp “ADC Reading” and the “Firmware Count.” this shows the waveform can reproduce accurately even with “Real-Time” graphing, provided “Flushing” is off.

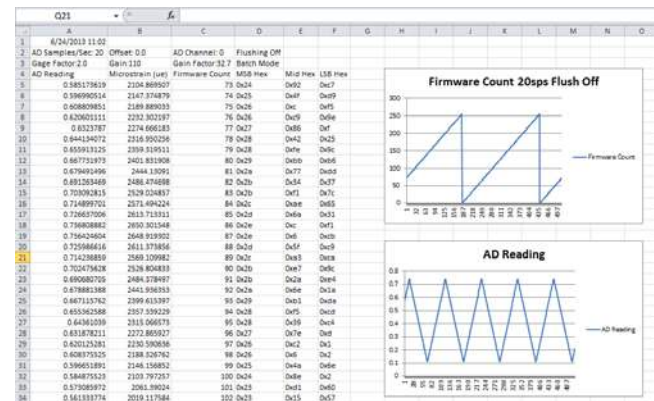

FIGURE 9. LOW FREQUENCY REAL TIME GRAPH WITH FLUSHING OFF

However, if “Flushing” is on, then measurements are skipped arbitrarily. Figure 10 is the same waveform and sample rate, but with “Flushing” enabled. Figure 8 Real Time Graph with Flushing On shows with “Flushing” on, the “Firmware Count” has missing values and the collected waveform is more jagged.

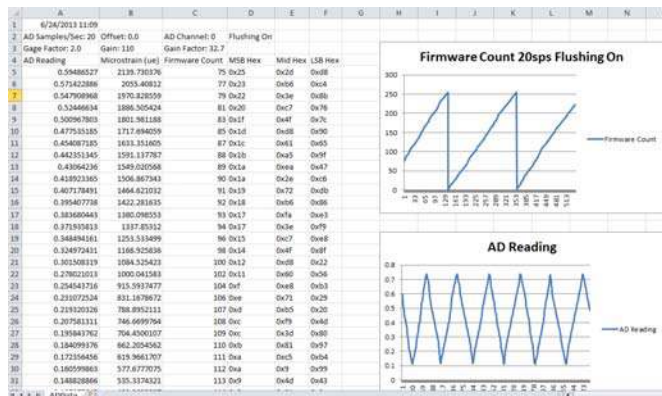

FIGURE 10. LOW FREQUENCY REAL TIME GRAPH WITH FLUSHING ON

TYPICAL THROUGHPUT AT 80 SPS

Finally, if we view the “Firmware Count” waveform at the default 80SPs, we can also see the effects of “Flush On” and “Flush Off” modes.

With “Flush On” at 80SPs, about every third measurement is collected. This yields a smoother sawtooth; however, again about every third measurement is actually collected. Figure 9 Running at 80SPs, with real-time graphing, about every third measurement is collected.

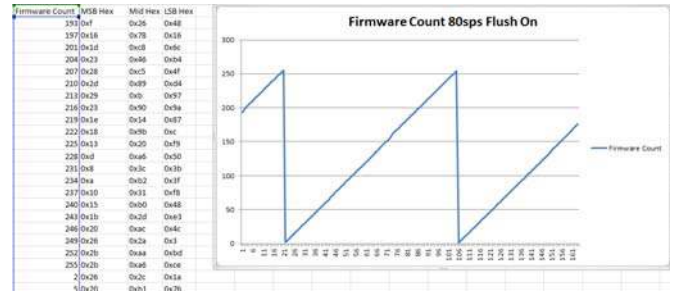

FIGURE 11. REAL TIME GRAPH 80SPs FLUSHING ON

With “Flush Off” at 80SPs, we get more continuous samples; however, large gaps occur when the USB buffer fills up and flushing is arbitrated by the USB driver.

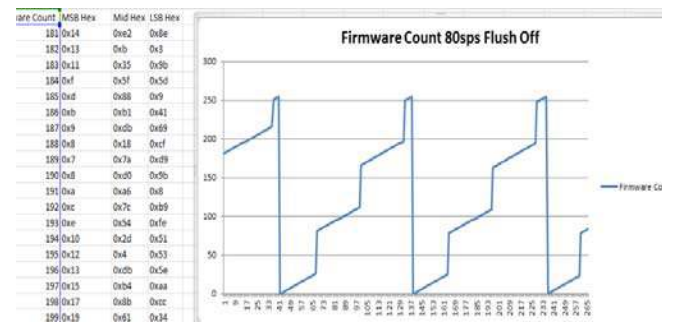

FIGURE 12. REAL TIME GRAPH 80SPS FLUSHING OFF

Figure 10 Running at 80SPs, with real time graphing and Flushing off; more continuous measurements are displayed, with larger gaps when USB buffers overflow.

Running at 80SPs, with real time graphing and “Flushing” off, more continuous measurements are displayed with larger gaps when USB buffers overflow.

THROUGHPUT SUMMARY

- Users can observe measurement throughput of an installation by examining the “Firmware Count” column in the Exported Data.
- Batch mode should be capable of collecting continuous measurements up to 400SPs. However, this value could be lower based on installation factors of a specific computer.
- The Flush On/Flush Off selection can be used to force real-time updates “Flush On” works better at higher sample rates and “Flush Off” works better with lower sample rates. Again, results may vary from installation-to-installation.

Bill of Materials

PART NUMBER	REF DES	QTY	VALUE	TOL	VOLTAGE	POWER	PACKAGE TYPE	JEDEC TYPE	MFR	DESCRIPTION
H1044-00103-16V10	C1, C6, C10, C24, C25	5	0.01µF	10%	16V		402	CAP_0402	GENERIC	Multilayer Cap
H1044-00104-16V10	C2, C5, C14, C16-C20, C22, C23, C27-C32	16	0.1µF	10%	16V		402	CAP_0402	GENERIC	Multilayer Cap
H1045-00105-16V20	C3, C11, C12, C26	4	1µF	20%	16V		603	CAP_0603	GENERIC	Ceramic Cap
H1065-00106-16V10	C4	1	10µF	10%	16V		1206	CAP_1206	GENERIC	Multilayer Cap
GRM21BR71C475KA73L	C7	1	4.7µF	10%	16V		805	CAP_0805	MURATA	CERAMIC CAP
H1046-00225-16V10	C8	1	2.2µF	10%	16V		805	CAP_0805	GENERIC	Multilayer Cap
H1044-00100-50V10	C9, C13	2	10pF	10%	50V		402	CAP_0402	GENERIC	Multilayer Cap
H1045-00334-25V10	C15	1	0.33µF	10%	25V		603	CAP_0603	GENERIC	Multilayer Cap
C0805C106K8PACTU	C21	1	10µF	10%	10V		805	CAP_0805	KEMET	Multilayer Cap
BAT54	D1	1					SINGLE	SOT23	DIODES	30V SCHOTTKY DIODE
MMSD4148T1	D2, D4-D6	4					SOD123	SOD123	ON-Semi	Switching Diode
597-3311-407	D3	1					SMD	DIA_LED1206	Dialight	Surface Mount Green LED
48037-1000	J1	1					MOLEX1	CON_USB_MOLEX_480371000	MOLEX	Right Angle USB A-Type Receptacle
PPPC062LJBN-RC	J2	1					DIP	CONN12	SULLINS	12 Pin Header 2.54mmx2.54mm (0.100) Connector RA
PAD_50	P1, P2	2					THOLE	PAD-50	GENERIC	0.050 Pad with 0.031 Plated Thru Hole
H2510-00R00-1/16W	R1, R6, R11	3	0	0%		1/16W	402	RES_0402	GENERIC	Thick Film Chip Resistor
H2510-01000-1/16W1	R2, R7	2	100	1%		1/16W	402	RES_0402	GENERIC	Thick Film Chip Resistor
H2510-01001-1/16W1	R3	1	1k	1%		1/16W	402	RES_0402	GENERIC	Thick Film Chip Resistor
H2510-01002-1/16W1	R8, R9, R28, R29	4	10k	1%		1/16W	402	RES_0402	GENERIC	Thick Film Chip Resistor
H2510-02210-1/16W1	R10	1	221	1%		1/16W	402	RES_0402	GENERIC	Thick Film Chip Resistor
H2510-04991-1/16W1	R12, R13, R20	3	4.99k	1%		1/16W	402	RES_0402	GENERIC	Thick Film Chip Resistor
H2510-049R9-1/16W1	R4, R5, R14, R15	4	49.9	1%		1/16W	402	RES_0402	GENERIC	Thick Film Chip Resistor
H2512-02490-1/10WR1	R16, R22, R25	3	249	0.1%		1/10W	805	RES_0805	GENERIC	Thick Film Chip Resistor
MCR03EZPFX3001	R17	1	3k	1%		1/10W	603	RES_0603	ROHM	Metal Film Chip Resistor
H2512-01000-1/10WR1	R18, R23, R26	3	100	0.1%		1/10W	805	RES_0805	GENERIC	Thick Film Chip Resistor

Bill of Materials (Continued)

PART NUMBER	REF DES	QTY	VALUE	TOL	VOLTAGE	POWER	PACKAGE TYPE	JEDEC TYPE	MFR	DESCRIPTION
H2512-00010-1/10W1	R19, R24, R27	3	1	1.0%		1/10W	805	RES_0805	GENERIC	Thick Film Chip Resistor
251206102Y1	L1	1	1µH				SMD	SM1210	FAIR-RITE	FERRITTE BEAD
ISL23328TFRUZ	U1	1					QFN	UTQFN16_102X71_157	INTERSIL	16 LEAD TQFN PACKAGE
ISL21010CFH341Z	U2	1					SOT	SOT23-3	INTERSIL	3 PIN SOT23-3 PACKAGE
ISL28233FRZ	U3	1					DFN3X3EP	DFN8_118X118_256_EP2	INTERSIL	8 PIN DFN 3x3 0.5 PITCH
ISL28634	U4	1					TSSOP	TSSOP14_173_256	INTERSIL	14 Pin 173 Mil TSSOP Package
ISL43741IRZ	U5	1					QFN	QFN20_157X157_197_EP	INTERSIL	20 LEAD QUAD FLAT PACKAGE (Pb-FREE)
ISL21090BFB825Z	U6	1					SOIC	SOIC8	INTERSIL	8 Pin 157 Mil Body SOIC Package
R5F10JBCANA	U7	1					QFN-S	QFN32_197X197_197_EPA	RENESAS	32 LEAD QUAD FLAT PACKAGE (Pb-FREE)
IP4220CZ6	U8	1					SOT457	SOT457	NXP	Dual USB 2.0 Integrated ESD Protection
ISL21010CFH333Z	U9	1					SOT	SOT23-3	INTERSIL	3 PIN SOT23-3 PACKAGE
ISL26104AVZ	U10	1					28P	TSSOP28_173_256	INTERSIL	28 Pin 0.65mm Pitch 4.4mmx9.7mm TSSOP Package
ISL54055IRVZ	U11	1					1_2X1A	UTDFN6_47X39_157_A	INTERSIL	6 PIN UTDFN-1.2x1A.4 Pitch Package
NX5032GA-12.000M-LN-CD-1	Y1	1					SM	XTAL_NX5032GA	NDK	12.000MHz SM Crystal

ISLRE-BDGSTKEV1Z Evaluation Board Layout

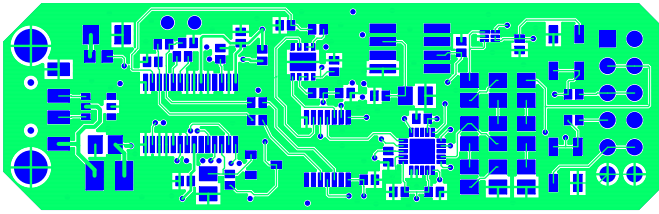

FIGURE 13. TOP LAYER

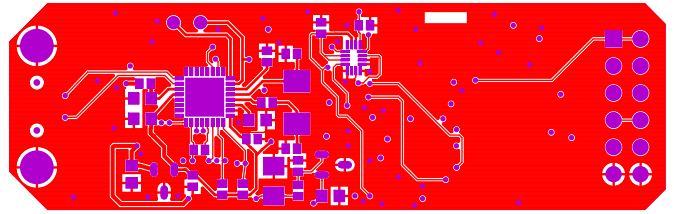
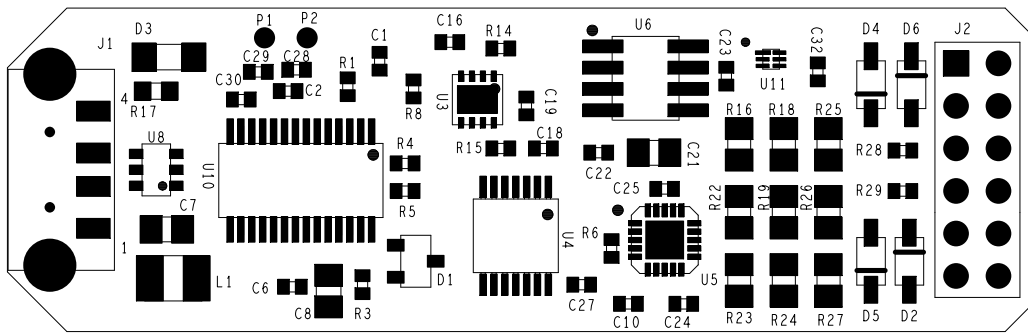
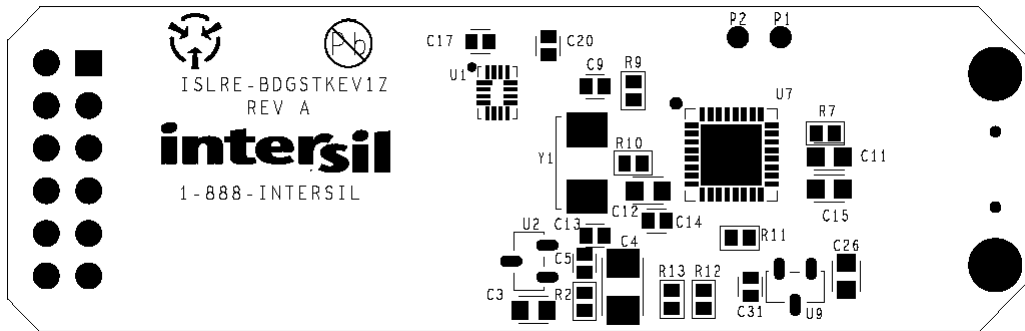

FIGURE 14. BOTTOM LAYER



TOP ASSEMBLY DRAWING



BOTTOM ASSEMBLY DRAWING

FIGURE 15. ASSEMBLY DRAWING

Intersil Corporation reserves the right to make changes in circuit design, software and/or specifications at any time without notice. Accordingly, the reader is cautioned to verify that the Application Note or Technical Brief is current before proceeding.

For information regarding Intersil Corporation and its products, see www.intersil.com

ISLRE-BDGSTKEV1Z Schematic

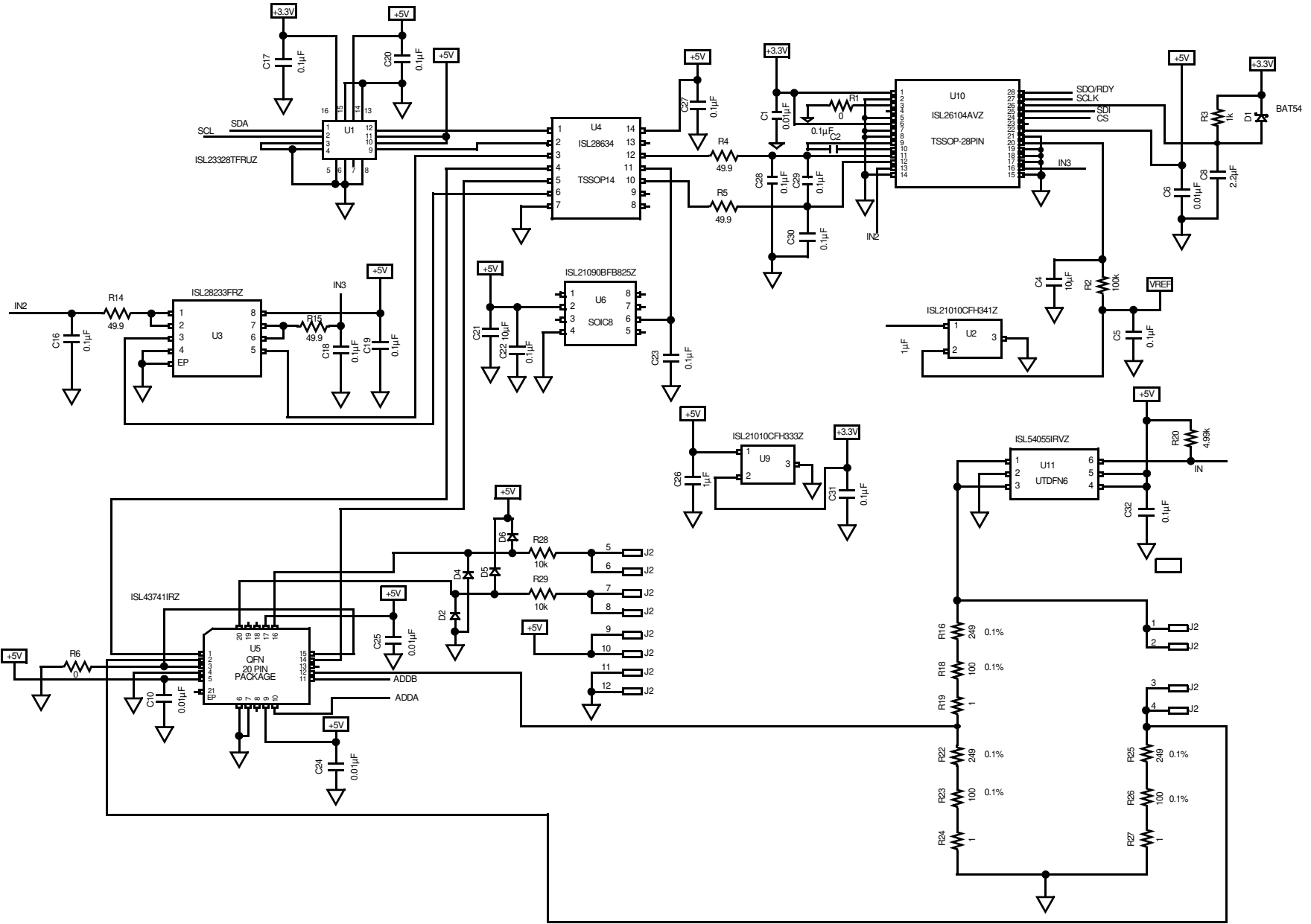

FIGURE 16. ISLRE-BDGSTKEV1Z STRAIN GAUGE SCHEMATIC

ISLRE-BDGSTKEV1Z Schematic (Continued)

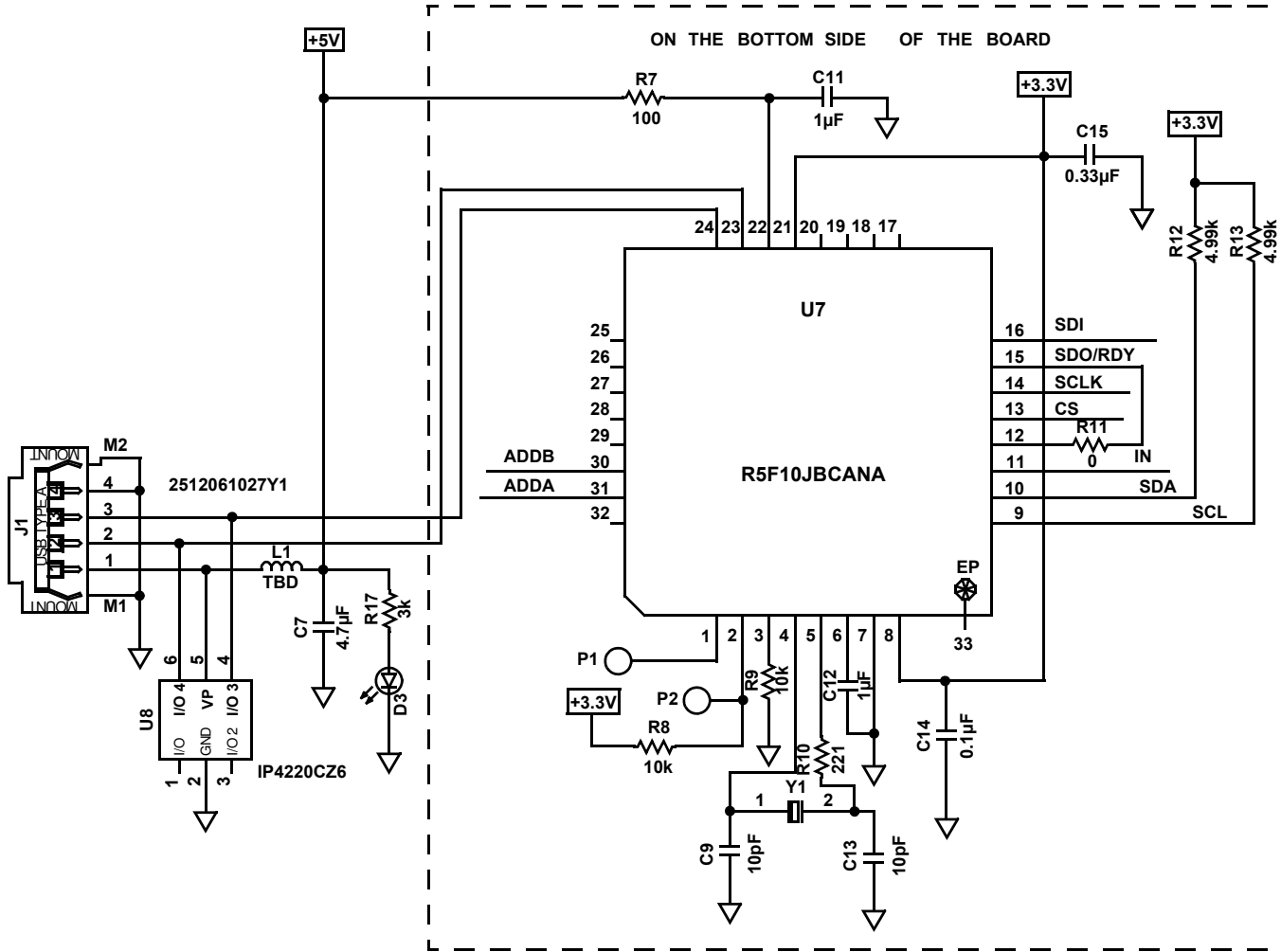

FIGURE 17. ISLRE-BDGSTKEV1Z MCU SCHEMATIC